Front-Panel Operation Reference

Volume 1 of 2

HP 1652B/HP 16538
Logic Analyzers



@Copyright Hewlett-Packard Company 1989

Manual Set Part Number 0165240902

Printed in the U.S.A. November 1989

Printing History

New editions are complete revisions of the manual. Update packages, which are issued between editions, contain additional and replacement pages to be merged into the manual by the customer. The dates on the title page change only when a new edition or a new update is published.

A software code may be printed before the date; this indicates the version level of the software product at the time of the manual or update was issued. Many product updates and **fixes** do not require manual changes and, conversely, manual corrections may be done without accompanying product changes. Therefore, do not expect a one to one correspondence between product updates and manual updates.

Edition 1

November 1989

0165290902

List of Effective Pages

The List of Effective Pages gives the date of the current edition and of any pages changed in updates to that edition. Within the manual, any page changed since the last edition is indicated by printing the date the changes were made on the bottom of the page. If an update is incorporated when a new edition of the manual is printed, the change dates are removed from the bottom of the pages and the new edition date is **listed** in Printing History and on the title page.

Pages	Effective Date
All	November 1989

Product Warranty

This Hewlett-Packard product has a warranty against defects in material and workmanship for a period of one year from date of shipment. During warranty period, Hewlett-Packard Company will, at its option, either repair or replace products that prove to be defective.

For warranty service or repair, this product must be returned to a service facility designated by Hewlett-Packard. However, warranty service for products installed by Hewlett-Packard and certain other products designated by Hewlett-Packard will be performed at the Buyer's facility at no charge within the Hewlett-Packard service travel area. Outside Hewlett-Packard service travel areas, warranty service will be performed at the Buyer's facility only upon Hewlett-Packard's prior agreement and the Buyer shall pay Hewlett-Packard's round trip travel expenses.

For products returned to Hewlett-Packard for warranty service, the Buyer shall prepay shipping charges to Hewlett-Packard and Hewlett-Packard shall pay shipping charges to return the product to the Buyer. However, the Buyer shall pay all shipping charges, duties, and taxes for products returned to Hewlett-Packard from another country.

Hewlett-Packard warrants that its software and firmware designated by Hewlett-Packard for use with an **instrument will** execute its **programming** instructions when properly installed on that instrument. Hewlett-Packard does not warrant that the operation of the instrument, software, or firmware will be uninterrupted or error free.

**Limitation Of
Warranty**

The foregoing warranty shall not apply to defects resulting from improper or inadequate maintenance by the Buyer, Buyer-supplied software, or interfacing, unauthorized modification or misuse, operation outside of the environmental specifications for the product, or improper site preparation or maintenance.

NO OTHER WARRANTY IS EXPRESSED OR IMPLIED.
HEWLETT-PACKARD SPECIFICALLY DISCLAIMS THE
IMPLIED WARRANTIES OR MERCHANTABILITY AND
FITNESS FOR A PARTICULAR PURPOSE.

Exclusive Remedies THE REMEDIES **PROVIDED** HEREIN ARE THE BUYERS SOLE AND EXCLUSIVE REMEDIES. HEWLETT-PACKARD SHALL NOT BE LIABLE FOR ANY DIRECT, INDIRECT, SPECIAL INCIDENTAL, OR CONSEQUENTIAL DAMAGES, WHETHER BASED ON CONTRACT, TORT, OR ANY OTHER LEGAL THEORY.

Assistance Product maintenance agreements and other customer assistance agreements are available for Hewlett-Packard products.

For any assistance, contact your nearest Hewlett-Packard Sales and Service Office. Addresses are provided at the back of this manual.

Certification Hewlett-Packard Company certifies that this product met its published specifications at the time of shipment from the factory. Hewlett-Packard further **certifies** that its calibration measurements are traceable to the United States National Bureau of Standards, to the extent allowed by the Bureau's calibration facility, and to the calibration facilities of other International Standards Organization members.

Safety This product has been designed and tested according to International Safety Requirements. To ensure safe operation and to keep the product safe, the information, cautions, and warnings in this manual must be heeded.

Introduction

About this manual...

Welcome to Hewlett-Packard logic analyzers. The HP 1652B/HP 1653B Logic Analyzer is more than just a logic analyzer. It is an analyzer and oscilloscope in one instrument. With this combination, you have expanded measurement capabilities.

This manual has been split into two volumes for better accessibility. Volume one contains general instrument information and operating reference information for the state analyzer. Also included is a state analyzer measurement example.

Volume two contains operating reference information and measurement examples for the timing analyzer and oscilloscope. To help put the total functionality of the instrument together, a measurement example for mixed mode operation (timing/state/scope) is included. Located in the back of volume two is the appendices which contain the seldom used information.

Information in both volumes is accessed easily by major tabs. All menu and field definitions are arranged by major function within each measurement type. In addition, both volumes have a master index.

The user interface of the HP 1652B/1653B was designed for the most intuitive operation as possible. Pop-up windows help lead you through setups and measurements so you won't have to memorize a lot of steps. As you read this manual and the other manuals about this logic analyzer, you will see just how easy the HP 1652B/1653B is to use.

If you aren't familiar with the HP 1652B/1653B Logic Analyzers, we suggest you read the HP 1652B/1653B Getting Started Guide. This guide contains tutorial examples on the basic functions of the logic analyzer and digitizing oscilloscope.

If you are new to logic analyzers and digitizing oscilloscopes, or just need a refresher, ***we think you'll find Feeling Comfortable with Logic Analyzers and Feeling Comfortable with Digitizing Oscilloscopes*** valuable reading. It will eliminate any misconceptions or confusion you may have about their application, and will show you how to get the most out of the measurement **functions**.

Please take time to **fill** out the "Your Comments Please" questionnaire. If it has already been used and you have any comments, address them to:

Hewlett-Packard
Atten: Publications Dept.
P.O. Box 2197
Colorado Springs, CO 80901-2197

Contents Volume 1

Chapter 1:	General Information	
	Logic Analyzer Description	1-1
	User Interface	1-1
	Configuration Capabilities	1-2
	Key Features	1-4
	Accessories Supplied	1-5
	Available Accessories	1-7
	Manuals Supplied	1-7
	Turning On the Logic Analyzer	1-7

Chapter 2:	Probing	
	Introduction	2-1
	Probing Options	2-1
	The HP 10320C User-Definable Interface	2-1
	The HP 10269C General Purpose Probe Interface	2-2
	General Purpose Probiis	2-3
	The Termination Adapter	2-3
	The HP1652B/53B Probiis System	2-4
	Probe Pod Assemblies	2-4
	Pod Grounding	2-5
	Probes	2-5
	Probe Grounding	2-6
	Grabbers	2-6
	Probe Cable	2-6
	Oscilloscope Probes	2-7
	Probe Inputs	2-7
	External Trigger Inputs	2-7
	Compensation Signal Output	2-7
	Signal Line Loading	2-8
	Maximum Probe Input Voltage	2-8
	Pod Thresholds	2-8
	Connecting the Logic Analyzer to the Target System.	2-8
	Connecting the Probe Cables to the Logic Analyzer	2-9
	Connecting the Pods to the Probe Cable	2-10

Disconnecting the Probes from the Pods2-11
Connecting the Grabbers to the Probes2-12
Connecting the Grabbers to the Test Points2-12
Labeling Pods, Probes, and Cables2-U

Chapter 3:

Using the Front-Panel User Interface

Introduction3- 1
Front-Panel Controls3-2
Rear-Panel Controls and Connectors3-6
The Cursor3- 7
How to Select Menus3- 7
How to Switch between the Analyzers and Oscilloscope3-8
Returning to the System Configuration Menu3-8
How to Select Fields3-9
Pop-up Menus3- 9
How to Close Pop-up Menu3-9
How to Select Options	3-10
Toggle Fields3-11
How to Enter Numeric Data3-11
How to Enter Alpha Data	3-14
Changing Alpha Entries	3-15
How to Roll Data	3-16
Assignment/Specification Menus	3-17
Assigning Pod Bits to Labels	3-17
Specifying Patterns3-18
Specifying Edges3-19

Chapter 4:

System Configuration Menu

Introduction	1
System Configuration Menu4-1
Accessing the System Configuration Menu4-2
System Configuration Menu Fields4-3
Name	3
Type	4
Scope On/Off4- 5
Autoscale4-5
Pods	6
Where to Go Next4- 7

Chapter 5:	I/O Menu	
	Introduction..	..5-1
	Accessing the I/O Menu	..5-1
	Print Screen	..5- 2
	Print All	..5- 2
	Disk Operations	..5-3
	Load	..5-5
	Store	..5-5
	Autoload	..5- 6
	copy	..5-7
	Duplicate Disk	..5- 8
	Pack Disk	..5-9
	Rename	..5- 9
	Purge	5-10
	Format Disk	..5-11
	I/O Port Configuration	..5-12
	Configuring the Interfaces	..5-13
	The HP-IB Interface	..5-13
	The RS-232C Interface	..5-14
	External BNC Configuration	..5-17
	Self Test	..5-18

Chapter 6:	Disk Drive Operations	
	Introduction	..6-1
	The Disk Operations Available	..6-1
	Accessing the Disk Menu	..6-3
	Selecting a Disk Operation	..6-4
	Disk Operation Parameters	..6-5
	Installing a Blank Disk	6-6
	Formatting a Disk	..6-7
	Storing to a Disk	6-9
	The Load Operation	..6-11
	Renaming a File	..6-12
	The Autoload Operation	..6-13
	Purging a File	..6-14
	Copying a File	..6-15
	The Pack Disk Operation	..6-17
	Duplicating the Operating System Disk	..6-18

Chapter 7:**Making Hardcopy Prints**

Introduction ..	7- 1
Supported Printers ..	7-1
Alternate Printers ..	7-2
Hooking Up Your Printer ..	7-2
HP-IB Printer Cables ..	7-3
RS-232C Printer Cables ..	7-3
HP 13242G Cable ..	7-3
HP 92219H Cable ..	7-4
Setting HP-IB for HP Printers ..	7-4
Setting RS-232C for HP Printers ..	7-5
Setting RS-232C for Your Non-HP Printer ..	7-5
Setting Paper Width ..	7-6
RS-232C Default Configuration ..	7-6
Recommended Protocol ..	7-6
Starting the Printout ..	7-7
Print Screen ..	7-7
Print All ..	7- 7
What Happens during a Printout? ..	7-8
Connecting to Other HP Printers ..	7-9

Chapter 8:**The State Analyzer**

Introduction ..	8-1
The State Analyzer: An Overview ..	8-1
State Analyzer Menu Maps ..	8-1
State Format Menu Map ..	8-2
State Trace Menu Map ..	8-3
State Listing Menu Map ..	8-5
State Compare Menu Map ..	8-6
State Waveform Menu Map ..	8-7
State Chart Menu Map ..	8-9

Chapter 9:**State Format Specification Menu**

Introduction9- 1
Accessing the State Format Specification Menu9-1
State Format Specification Menu9-1
State Format Specification Menu Fields9-3
Label9-3
Turn Label On9- 4
Modify Label9- 4
Turn Label Off9- 4
Polarity (Pol)9-4
Bit Assignment9- 4
Pod Threshold9-6
Specify Symbols9-7
Clock9- 7
Pod Clock9-9
Normal9- 9
Demultiplex9-10
Mixed Clocks9-11
Clock Period9-12
Specify Symbols Menu9-12
Specify Symbols Menu Fields9-13
Label9-13
Base9-14
Symbol View Size9-15
Symbol Name9-15
Leaving the Symbol Table Menu9-17

Chapter 10:**State Trace Menu**

Introduction10-1
Accessing the State Trace Menu10-2
State Trace Menu Fields10-2
Sequence Levels10-6
Insert Level10-7
Delete Level10-7
Storage Qualifier10-8
Branching Qualifier10-8
Occurrence Counter10-9

Storage Macro	10-9
Reading the Sequence Level Display	10-11
Acquisition Fields	10-13
Trace Mode	10-13
Armed By	10-13
Branches	10-14
Off	10-14
Restart	10-14
Per Level	10-15
count	10-18
Off..	10-18
Time	10-18
States	10-20
Prestore	10-21
Qualifier and Pattern Fields	10-22
Label	10-22
Base	10-22
Qualifier Field	10-23
Patterns	10-23
Ranges	10-24
Pattern Fields	10-24

Chapter 11:

State Listing Menu	
Introduction	11-1
Accessing the State Listing Menu	11-2
State Listing Menu Fields	11-3
Markers	11-3
Markers:Off	11-4
Markers: Patterns	11-4
Stop Measurement	11-5
Markers: Time	11-6
Markers: Statistics	11-6
Pattern <u> </u> Field..	11-7

Chapter 12:	State Compare Menu	
	Introduction..	12-1
	Accessing the Compare Menu	12-2
	The Compare and Difference Listing Displays	12-2
	The Compare Listing	12-2
	The Difference Listing	12-2
	Creating a Compare Image	12-3
	Bit Editing of the Compare Image	12-4
	Masking Channels in the Compare Image	12-5
	Specifying a Compare Range	12-6
	Repetitive Comparisons with a Stop Condition	12-7
	Locating Mismatches in the Difference Listing	12-8
	Saving Compare Images	12-8

Chapter 13:	State Chart Menu	
	Introduction	13-1
	Accessing the State Chart Menu	13-1
	Selecting the Axes for the Chart	13-1
	Scaling the Axes	13-2
	The Label Value vs. States Chart	13-3
	The Label Value vs. Label Value Chart	13-4
	X & O Markers and Readouts for Chart	13-5
	Marker Options	13-6

Chapter 14:	State Waveforms Menu	
	Introduction	14-1
	Accessing the State Waveforms Menu	14-1
	Selecting a Waveform	14-2
	Replacing Waveforms	14-3
	Deleting Waveforms	14-4
	Selecting States per Division	14-4
	Delay from Trigger	14-5
	State Waveform Display Features	14-5
	X and 0 Markers for State Waveform	14-5

Chapter 15:**State Analyzer Measurement Example**

Introduction	15-1
Problem Solving with the State Analyzer	15-2
What Am I Going to Measure?	15-2
How Do I Configure the Logic Analyzer?	15-4
Connecting the Probes	15-6
Activity Indicators	15-6
Configuring the State Analyzer	15-7
Specifying the J Clock	15-9
Specifying a Trigger Condition	15-10
Acquiring the Data	15-12
The State Listing	15-13
Finding the Answer	15-14
Summary	15-16

Index

General Information

Logic Analyzer Description

The HP 1652B/1653B logic analyzers are general purpose logic analyzers with oscilloscope measurement capabilities. These **analyzers** are designed as stand alone instruments for use by digital and microprocessor designers. Both the HP 1652B and HP 1653B have HP-IB and RS-232C interfaces for hardcopy printouts and control by a host computer. With faster state analysis, **oscilloscope** measurement capabilities and the improved features, the HP 1652B/53B analyzers **will** accommodate next generation design tasks.

The HP 1652B, is capable of 100 MHz timing and 35 MHz state analysis on **80** channels. The HP 1653B, is capable of 100 MHz timing and 25 MHz state analysis on 32 channels. You **will** use the same **manual** set regardless of whether you have an HP 1652B or an HP 1653B.

Both analyzers have the same 2-channel, **400-megasample/second**, 100 MHz single-shot and repetitive single-shot digitizing oscilloscope measurement capabilities.

User Interface

Fist-time and casual users as **well** as experienced logic analyzer users **will find** the user interface easier to use than in previous generations.

The front panel is **controlled** by a front-panel keyboard, and the addition of a "KNOB" **allows** you to move the cursor or change settings more quickly than before. The timing **analyzer** (a close cousin of the oscilloscope) now has oscilloscope-type controls which more closely match the type of measurements you make with the timing analyzer. Information is displayed on a nine-inch white phosphor CRT.

Configuration Capabilities

The HP 1652B/1653B can be configured either as **two** independent machines (analyzers) or as two interactive machines. No matter how the analyzers are configured, up to two channels of oscilloscope measurement can be added. The configurations for each analyzer includes the following.

HP 1652B:

- Up to **80** channels state and up to two channels oscilloscope.
- Up to 80 channels timing and up to **two** channels oscilloscope.
- Two state machines with multiples of 16 channels per machine, with a combined maximum of 80 channels and up to two channels oscilloscope.
- One state and one timing machine with multiples of 16 channels per machine, with a **combined** maximum of **80** channels and up to two channels oscilloscope.
- Up to two channels of oscilloscope.

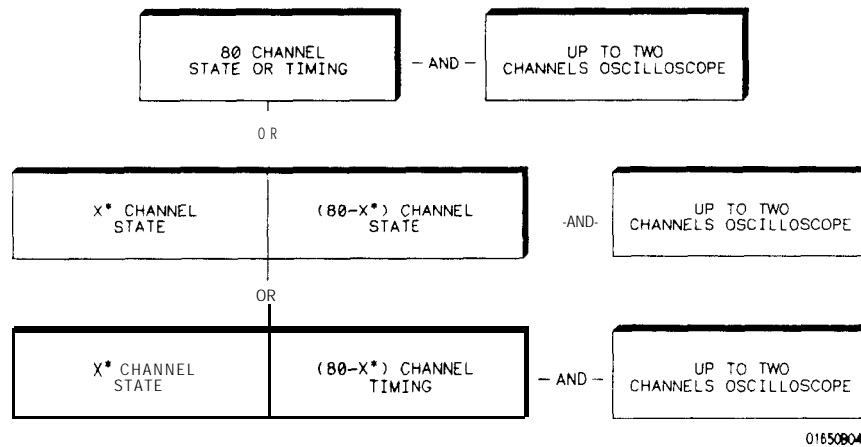

Figure I-I. HP 16528 Configuration Capabilities

*multiples of 16 channels

HP 1653B:

- Up to 32 channels state and up to **two** channels oscilloscope.
- Up to **32** channels timing and up to **two** channels oscilloscope.
- Two state machines **with** multiples of 16 channels per machine, with a combined maximum of 32 channels and up to two channels oscilloscope.
- One state and one timing machine with multiples of 16 channels per **machine, with** a combined maximum of 32 channels and up to two channels oscilloscope.
- Up to **two** channels of oscilloscope.

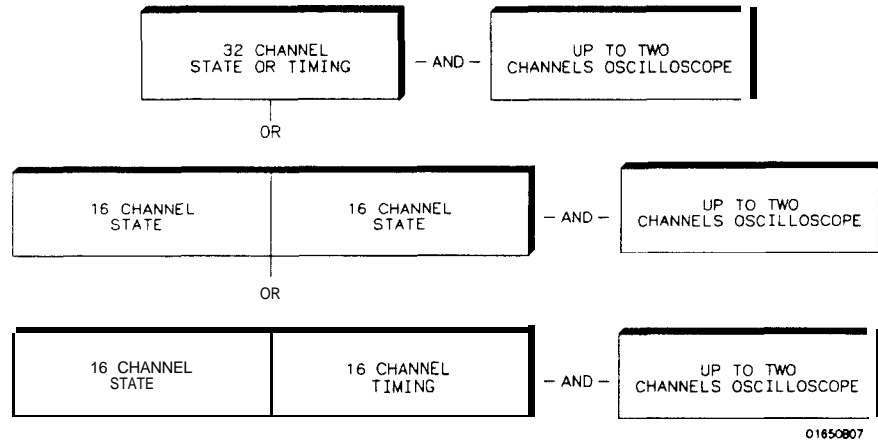

Figure 1-2. HP 16636 Configuration Capabilities

Key Features

A 3.5-inch disk drive is built into the instrument for storing logic analyzer and oscilloscope configurations and acquired data. The disk drive also provides a way of loading inverse assembly configuration files into the logic analyzer for easy con&ring. Some common features of the logic analyzer and oscilloscope include lightweight passive probes for easy hook-up, mixed-mode display, HP-IB and RS-232C interfaces for programming and printer output.

Logic analyzer key features include:

- Transitional timing for extended timing analyzer memory.
- All channels can be used for state or timing.
- An external trigger BNC connector.
- Transitional or glitch timing modes.
- 1 k deep memory on all channels.
- Glitch detection.
- Marker measurements.
- Triggering and pattern qualification.
- Overlapping of timing waveforms.
- Eight sequence levels.
- Eight pattern recognizers.
- One range recognizer.
- Time and number-of-states tagging.
- Pre-store.
- Autoscale.
- Programmability.
- Cross-domain triggering.
- Interactive measurements.
- Oscilloscope-type controls in the timing analyzer.
- State Compare, Chart, and Waveform modes.

Oscilloscope key features include:

- 400 Megasample/second digitizing rate.
- 100 MHz single-shot (real-time) bandwidth.
- 4 ksamples per measurement per channel.
- Automatic waveform scaling.

- ECL and **TTL** presets.
- Automatic pulse parameter measurements.
- Channel-to-channel time interval measurements.
- Markers for time and voltage readouts.
- **6-bit** resolution.
- Probe attenuation from **1:1** to **1000:1**.
- **50Ω** dc or 1 **MΩ** dc input coupling.
- Edge or immediate triggering.
- Delayed trigger by events and/or time.
- Trigger point marker displayed.
- Normal, average, or cumulative acquisitions.
- Connect-the-dots.
- Chan + **Chan**, Chart-Chan, and waveform overlay.

Accessories Supplied

Table I-1 lists the accessories supplied with your HP **1652B/53B**. If any of these accessories were missing when you received the logic analyzer from the factory, contact your nearest Hewlett-Packard **office**.

Accessory	HP Part No.	Quantity	
		1652B	1653B
Probe assemblies	01650-61608	5	2
Probe cables	01650-61607	5	2
BNC Adapter 90°	1250-0076	2	2
BNC-to-mini probe adapter	1250-1454	1	1
Grabbers (Note 1)	5959-0288	100	40
Probe Leads (Note 2)	5959-9333	85	34
Ground leads (long) (Note 2)	5959-9335	10	4
Ground leads (short) (Note 2)	5959-9334	5	2
RS-232C loop back adapter	01650-63202	1	1
Probe and probe cable numbering label card	01650-94303	1	1
Mini-probes 10:1, 1 MΩ, 10 pF, 2 m	HP 10433A	2	2
AC power cable	See Note 3	1	1
Operating system disk	Cd1	2	2
Operating and Programming manual set	01652-90902	1	1
Service Manual	01652-90901	1	1

Table I-I. Accessories Supplied

Notes:

1. Package of 20 per part number. The quantity in the table only indicates what is shipped with the instrument.
2. Package of 5 per part number. These items are shipped assembled as a 01650-61608. The part numbers are provided for replacement orders. The quantity in the above table only indicates what is sent with the instrument.
3. The type of power cord you receive with your logic analyzer depends on your country. Complete information about power cord options is in Appendix D of this manual.

Available Accessories

In addition to the accessories supplied, there are a number of accessories available that will make your measurement tasks easier and more accurate. You will find these listed in **Accessories for HP Logic Analyzers**.

Manuals Supplied

The manuals supplied with your logic analyzer are as follows:

- **Feeling Comfortable with Logic Analyzers** - A primer on logic analyzers.
- **Feeling Comfortable with Digitizing Oscilloscopes** - A primer on digitizing oscilloscopes.
- **Getting Started with the HP 1652B/1653B Logic Analyzer** - A tutorial for new and casual users.
- **HP 1652B/1653B Front Panel Operation Reference Manual** - A complete operating manual.
- **HP 16528116538 Programming Reference** - A complete reference to programming commands.
- **Service Manual** - A guide to troubleshooting and module-level repair.

Turning On the Logic Analyzer

Before you turn your logic analyzer on, refer to Appendix D for information covering installation and set up of your logic analyzer.

Note 

Do not turn on the logic analyzer before you remove the yellow shipping disk from the disk drive.

If you are unfamiliar with how to use the HP 1652B/1653B logic analyzers, refer to chapter 1 of the **Getting Started with the HP 1652B/1653B Logic Analyzer**.

Probing

Introduction

This chapter contains a description of the probing system of the HP **1652B/1653B** logic analyzers. It **also** contains the information you need for connecting the probe system components to each other, to the logic analyzer and oscilloscope, and to the system under test.

Probing Options

You can connect the HP **1652B/1653B** logic analyzers to your system under test in one of the following **ways**:

- HP **10320C** User-Definable Interface (optional).
- HP **10269C** with microprocessor specific modules (optional).
- The standard HP **1652B/53B probes** (general purpose probing.)
- Direct connection to a **20-pin 3M[®]** 'Series type header connector using the optional termination adapter (HP part number 01650-63201).

The HP **10320C** User-Definable Interface

The optional HP **10320C** User-Definable Interface module combined with the optional HP **10269C** General Purpose Probe Interface **allows you to connect** the HP **1652B/1653B logic** analyzers to the microprocessor in your target system. The HP **10320C** includes a breadboard (HP 64651B) which you custom wire for your system.

Another option for use with the HP **10320C** is the HP **10321A** Microprocessor Interface Kit. This kit includes sockets, bypass capacitors and a fuse for power distribution. Also included are wire-wrap headers to simplify wiring of your interface when you need active devices to support the connection requirements of your system.

You **will find** additional information about the HP **10320C** and HP **10321A** **in** the **Accessories for HP Logic Analyzers** data sheet.

The HP 10269C General Purpose Probe Interface

Instead of connecting the **analyzer** probe tips directly to the signal lines, you may use the optional HP 10269C General Purpose Probe Interface. The HP 10269C allows you to connect the probe cables, without the probes, to connectors on the interface. When the appropriate preprocessor is installed in the interface, you will have a direct connection between the logic analyzer and the microprocessor under test. See figure 2-1 for a basic block diagram.

There are a number of microprocessor specific preprocessors available as optional accessories which are listed in the *Accessories for HP Logic Analyzers* data sheet. Appendix A of this manual also introduces you to preprocessors and inverse assemblers.

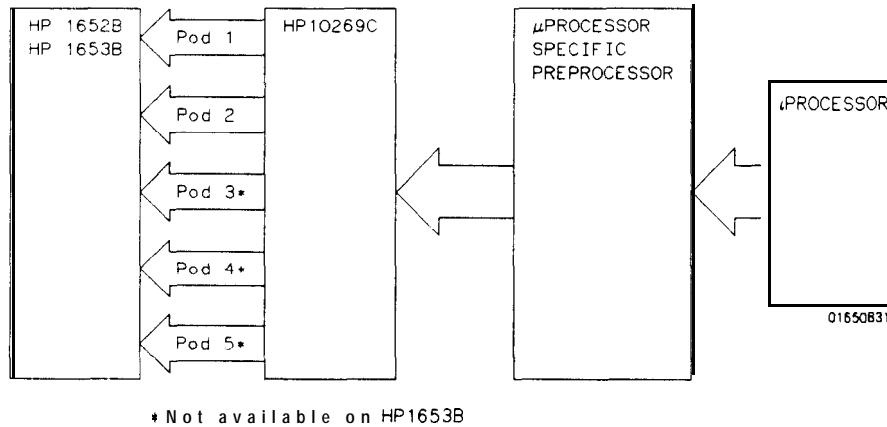

Figure 2-1. HP 10269C with Preprocessor

General Purpose Probing

General purpose probing involves connecting the logic analyzer and oscilloscope probes directly to your target system without using any interface. General purpose probing does not limit you to specific hook up schemes, for an example, as the probe interface does.

The Termination Adapter

The optional termination adapter (HP part number 01650-63201) allows you to connect the logic analyzer probe cables directly to test ports on your target system without the probes. However, since the probes contain the proper termination for the logic analyzer inputs, a termination must be provided.

The termination adapter shown below, is designed to **connect** to a **20 (2x10)** position, **4-wall**, low profile header connector, **3M[®] Series 3592** or equivalent.

To hook up the adapter, connect the termination adapter to the analyzer probe cable. Connect the other end of the adapter directly to your test port.

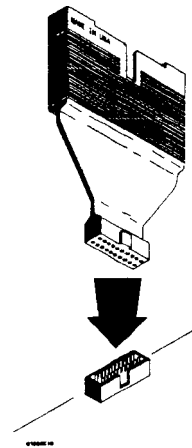

Figure 2-2. Termination Adapter

The HP1652B/1653B Probing System

The standard HP 1652B/53B probing system consists of logic analyzer probes and oscilloscope probes. Both have a passive design which means there are no active circuits at the outer end of the cable. The passive design also enables the pods and probes to be smaller and lighter, there by making them easier to use.

The logic analyzer probing system consists of flat ribbon probe cables, a probe housing, probe leads, ground leads and grabbers. This passive probing system is similar to the probing system used with high frequency oscilloscopes. It consists of a series R-C network (100 k Ω in parallel with 8 pF) at the probe tip, and a shielded resistive transmission line. The advantages of this system include the following:

- 2 ns risetime with $\pm 5\%$ perturbations
- 8 pF input capacitance at the probe tip
- Signal ground at the probe tip for higher speed timing signals
- Inexpensive removable probe tip assemblies

Probe Pod Assemblies

Probes and probe pod assemblies allow you to connect the logic analyzer to your system under test without the HP 10269C Probe Interface. This general purpose probing is useful for discrete digital circuits. Each pod, as they will be referred to for consistency, contains, 16 probes (data channels), one clock channel, and a pod ground. See the figure below.

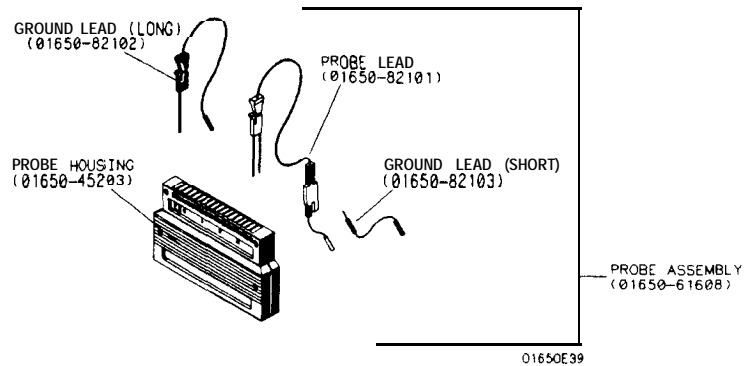

Figure 2-3. Probe Pod Assembly

Pod Grounding

Each pod is grounded by a pod ground lead that should always be used. You can connect the ground lead directly to a ground pin on your target system or use a grabber. The grabber connects to the ground lead the same way it connects to the probe lead. To connect the ground lead to grounded pins on your target system, you must use 0.63 mm (0.025 in.) square pins or round pins with a diameter of 0.66 mm (0.026 in) to 0.84 mm (0.033 in).

Probes

The probe consists of a **12-inch** twisted pair cable and one grabber. The probe tip, which connects to the target system, has an integrated R-C network with an input impedance of 100 **k Ω** in parallel with approximately 8 **pF**. See figure 2-4 below.

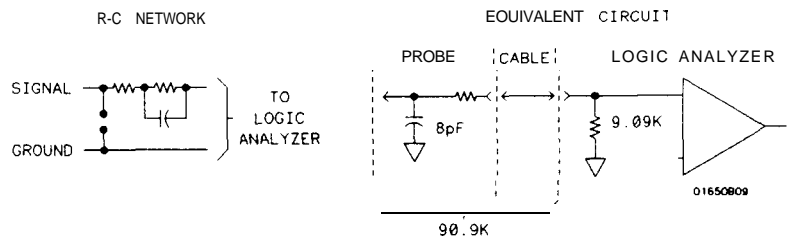
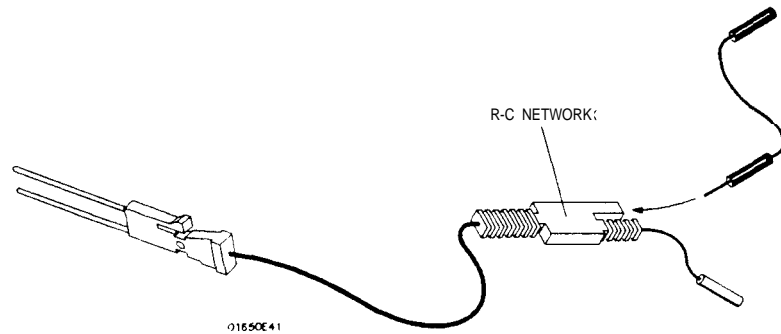

Figure 2-4. Probe Input Circuit

The other end of the probe has a two-pin **connector** that snaps into the pod's probe housing. See figure 2-5.



2-5. Probe

Probe Grounding

You can ground the probes in one of two ways. You can ground the probes with the pod ground only; however, the ground path won't be the same length as the signal path through the probe. If your probe ground path must be the same as your signal path, use the short ground lead (probe ground). The probe ground lead connects to the molded probe body via a pin and socket. You can then use a grabber or grounded pins on your target system the same way as the pod ground,



For improved signal fidelity, use a probe ground for every four probes in addition to the pod ground.

If you need additional probe ground leads, order HP part number 5959-9334 from your nearest Hewlett-Packard sales **office**.

Grabbers

The grabbers have a hook that fits around IC pins and component leads and connects to the probes and the ground leads. The grabbers have been designed to fit on adjacent IC pins.

Probe Cable

The probe cable contains 17 signal lines, 17 chassis ground lines and two power lines (for preprocessor use) that are woven together into a flat ribbon that is **4.5** feet long. The probe cable connects the logic analyzer to the pods, termination adapter, or the HP **10269C** General Purpose Probe Interface.

Both ends of the cable are alike, so you can connect either end to the pods or logic analyzer. Each cable is capable of carrying 0.60 amps for preprocessor power.



DO NOT exceed this 0.66 amps per cable or the cable will be damaged. Also, the maximum power available from the logic analyzer (all cables) is 2 amps at 5 volts.



Preprocessor power is protected by a current limiting circuit. If current exceeds 2.3 amps, the circuit will open. The current limiting circuit will try to reset itself every **20** ms until the shorted condition is **fixed**.

Oscilloscope Probes

The two oscilloscope probes supplied with the HP 1652B/1653B Logic Analyzer are the HP 10433A Miniature Passive Probes. These small, lightweight probes allow measurements that were previously very difficult in densely populated circuits.

For complete information on the operation, maintenance, and adjustments of the miniature passive probes, be sure to read the operating note that is packaged with the probes.

Probe Inputs

Probe inputs are located on the front panel below the Knob. Input 1 (CH 1) is on the left. The probes may be connected directly to the BNC input connectors. The signal is dc coupled to the oscilloscope.

BNC cables can be connected directly to the BNC connectors. The HP 10503A 1.2 meter BNC-to-BNC cable is not provided with the instrument, but, you can order it, separately.

External Trigger Inputs

The External Trigger Input BNC is located on the rear panel. A probe may be connected directly to this BNC. The External Trigger input allows the analyzer to be triggered by a pulse applied to this BNC. The analyzer then in turn internally arms the scope.

BNC cables can be connected directly to the BNC connectors. The HP 10503A 1.2 meter BNC-to-BNC cable is not provided with the instrument, but, you can order it, separately.

Compensation Signal Output

The Compensation **Signal** Output BNC is located on the rear panel. The Compensation Signal **50Ω** output is ~ 1.2 kHz square wave with high amplitude near -200 mV and low amplitude near -400 mV when connected to a **50Ω** load. This square wave is used for probe compensation adjustment (see your operating note for more information about probing) and is used in examples throughout this manual.

Signal Line Loading

Any signal line you intend to probe with the logic analyzer probes, must supply a minimum of 600 **mV** to the probe tip. The probes have an input impedance of 100 **k Ω** shunted by 8 **pF**. If the signal line is incapable of this minimum voltage, you will not only have an incorrect measurement, but the system under test may also malfunction.

Maximum Probe Input Voltage

The maximum input voltage of each logic analyzer probe is ± 40 volts peak.

The maximum input voltage of the oscilloscope probes is ± 250 volts dc at 1 **M Ω** setting and 5 volts rms at 50 **Ω** setting.

Pod Thresholds

Logic analyzer pods have two preset thresholds and a user-definable pod threshold. The two preset thresholds are ECL (- 1.3 V) and **TTL** (+ 1.6 V). The user-definable threshold can be set anywhere between -9.9 volts and + 9.9 volts in 0.1 volt increments.

The pod thresholds of pods 1 and 2 in the HP 1653B and of pods 1, 2, and 3 in the HP 1652B can be set independently. The pod thresholds of pods 4 and 5 in the HP 1652B are slaved together. Therefore, when you set the threshold on either pod 4 or 5, both thresholds will be the same.

Connecting the Logic Analyzer to the Target System

There are four ways you can connect the logic analyzer to your target system: the probes (general purpose probing); the HP 10320C User-definable Interface; the HP 10269C with microprocessor specific preprocessor modules; and direct connection to a 20 pin 3M[®] Series type header connector using the optional termination adapter (HP part number 01650-63201).

Since the probe interface hookups are microprocessor specific, they will be explained in their respective microprocessor operating notes. The rest of this chapter is dedicated to general purpose probing with the logic analyzer probes.

Connecting the Probe Cables to the Logic Analyzer

You connect the probe cables to the probe cable connectors located on the rear panel of the logic analyzer. The probe cable connectors are keyed for proper orientation. You can connect either end of the cable to the rear panel **since** both ends of the cables are alike.

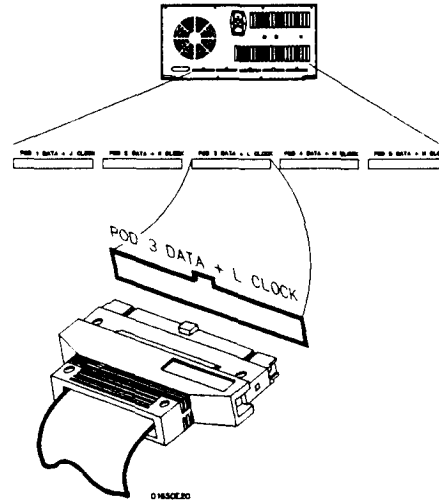

Figure 2-6. Probe Cable to Analyzer Connection

Connecting the Pods to the Probe Cable

The analyzer pods of the HP 1652B/53B differ from other logic analyzers in that they are passive (have no active circuits at the outer end of the cable). The pods, are the connector bodies (as shown below) that the probes are installed in when you receive your logic analyzer.

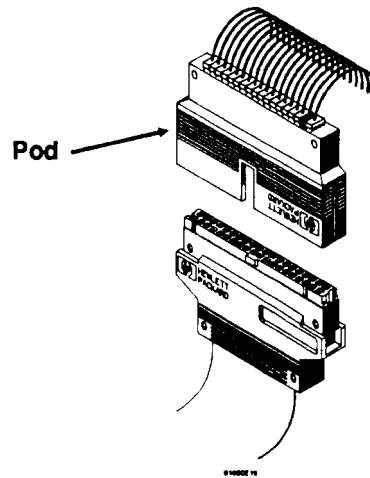

Figure 2-7. Connecting Pods to Probe Cables

To connect a pod to a cable, **align** the key on the cable connector with **the** slot on the pod connector and press together.

Disconnecting the Probes from the Pods

When you receive the logic analyzer, the probes are already installed in the pods. To keep them out of your way, disconnect them from the pod.

To disconnect a probe, insert the tip of a ball-point pen into the latch opening. Push on the latch while gently pulling the probe out of the pod connector as shown below.

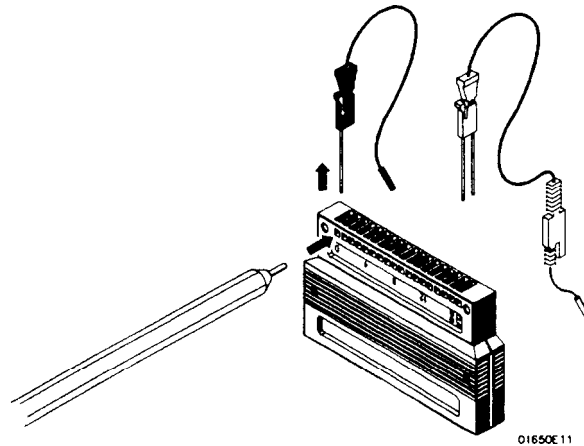

Figure 2-8. Disconnecting Probes From Pods

You connect the probes to the pods by inserting the double pin end of the probe into the pod. The probes and pod connector body are both keyed (beveled) so that they will fit together only one way.

Connecting the Grabbers to the Probes

Connect the grabbers to the probes by slipping the connector at the end of the probe onto the recessed pin located in the side of the grabber. If you need to use grabbers for either the pod or the probe grounds, connect the grabbers to the ground leads in the same manner.

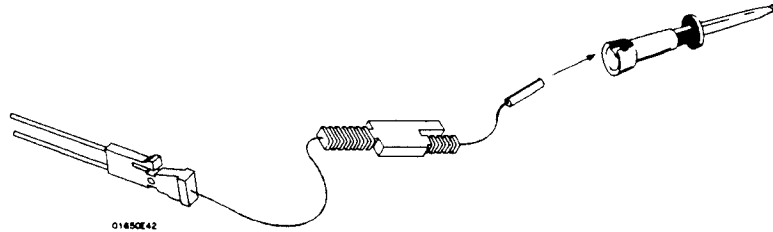

Figure 2-9. Connecting Grabbers to Probes

Connecting the Grabbers to the Test Points

The grabbers have a hook that fits around the IC pins and component leads. Connect the grabber to the test point by pushing the rear of the grabber to expose the hook. Hook the lead and release your thumb as shown below.

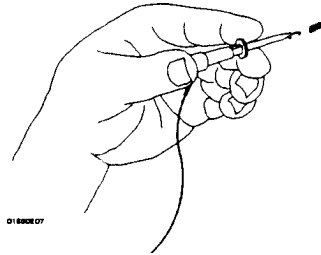

Figure 2-10. Connecting Grabbers to Test Points

Labeling Pods, Probes, and Cables

Included with your logic analyzer are self-adhesive labels for each pod, cable and probe. Use these sets of labels for identification.

Each set has labels for each end of the cable, a label for the probe housing, a label for the clock probe and **15** labels for each of the channels. The figure below, shows the correct placement of the labels.

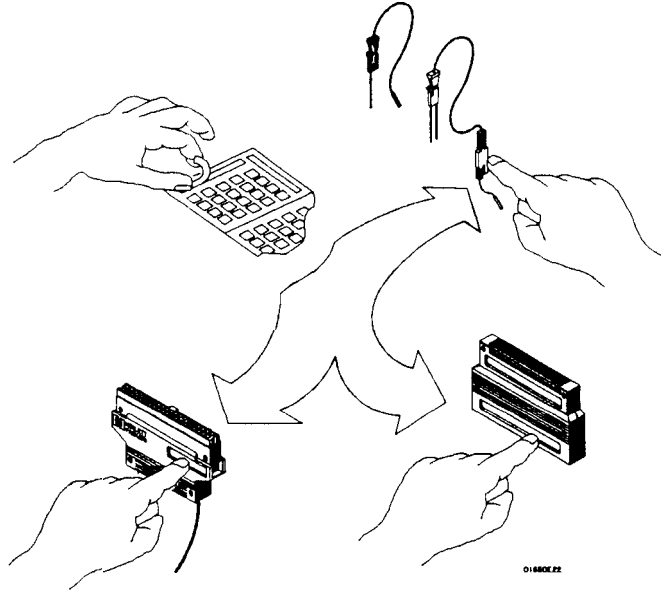

Figure 2-11. Labeling Pods, Probes and Cables

Using the Frdnt-Panel User Interface

Introduction

This chapter explains how to use the front-panel user interface. The front and rear-panel controls and connectors are explained in the first part of this chapter followed by “How to use...” explanations of the front-panel user interface.

The front-panel user interface consists of front-panel keys, the KNOB, and display. The interface allows you to **configure** the logic analyzer, oscilloscope and each analyzer (machine) within the logic analyzer. It also displays acquired data and measurement results.

Using the front-panel user interface involves the following processes:

- Selecting the desired menu with the menu keys.
- Placing the cursor on the desired field within the menu by rotating the KNOB.
- Displaying the field options or current data by pressing the SELECT key.
- Selecting the desired option by rotating the KNOB or entering new data by using the KNOB or the keypad.
- Starting and stopping data acquisition by using the RUN and STOP keys.

Front-Panel Controls

In order to apply the user interface quickly, you should know what the front-panel controls do.

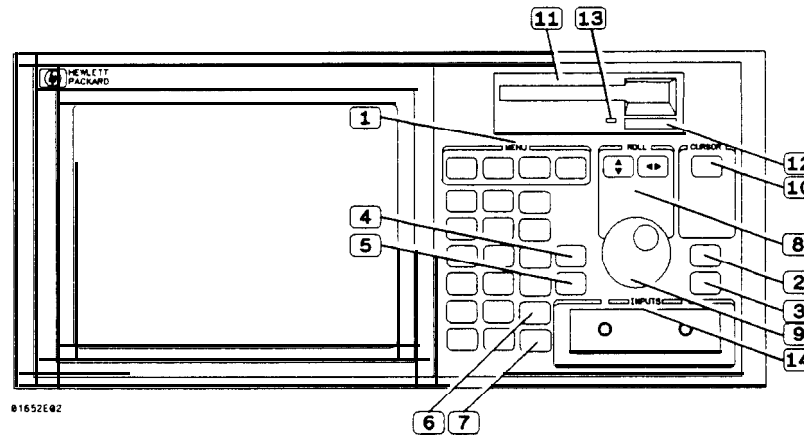

Figure 3-1. HP 1652B/53B Front Panel

- 1 Menu Keys.** The menu keys allow you to select the main menus in the logic analyzer. These keys are **FORMAT/CHAN**, **TRACE/TRIG**, **DISPLAY**, and **I/O**. The Format/Channel, **Trace/Trigger**, and Display keys will display the menus of either analyzer (machine) 1 or 2 respectively or the oscilloscope depending on what menu was last displayed or what you did in the System Configuration menu.

Format/Channel Menu Key. The **FORMAT/CHAN** menu key allows you to access either the Timing Format Specification, State Format Specification, or Oscilloscope Channel menus. You exit the Format/Channel menu by pressing another menu key or by returning to the System Configuration menu from this menu.

Trace/Trigger Menu Key. The **TRACE/TRIG** menu key allows you to access either the Timing Trace, State Trace, or Oscilloscope Trigger menus. You exit the Trace/Trigger menu by pressing another menu key or by returning to the System Configuration menu from this menu.

Display Menu Key. The **DISPLAY** menu key **allows** you to access either the Timing Waveforms display, State Listing display, or the **Oscilloscope** Waveforms display. You exit the Timing Waveforms, State Listing, and Oscilloscope Waveforms menus by pressing another menu key or by returning to the System Configuration menu.

I/O Menu Key. The I/O menu key allows you to access the I/O menu. You can access the I/O menu from any menu in either analyzer (timing or state) or oscilloscope, and at any time. Pressing the I/O menu key causes the I/O menu to pop up over any current menu on the display.

0² **Run Key.** The RUN key allows you to initiate a data acquisition and display cycle. The analyzer (state or timing) or oscilloscope is automatically forced into its display menu when a **run** is initiated. The trace mode or run mode you select (in the **Trace/Trigger** menu) determines whether a single or multiple (repetitive) run occurs.

3 **Stop key.** The STOP key allows you to stop data acquisition or printing. A single press always stops the data acquisition. The data displayed on screen depends on which acquisition mode (single or repetitive) was used to acquire the data. In the repetitive mode, STOP causes the old display to remain unchanged as long as the old data is not corrupt. In single mode, STOP causes any new data to be displayed. If printing a hardcopy, the STOP key stops the print.

0⁴ **Don't Care Key.** The DON'T CARE key **allows** you to enter don't cares in binary octal, and hexadecimal pattern specification fields. In Alpha Entry fields, this key enters a space and moves the underscore marker to the next space.

5 **Clear Entry Key.** The CLEAR ENTRY key allows you to perform the following tasks:

- Return decimal values to the previous value in the decimal menu fields.
- Return values to don't cares in menu fields with number bases other than decimal
- Clear Alpha Entry menus.
- Move the underscore marker or cursor to its original position in the menu fields.

⑥ **Hex(adecimal) Keypad.** The HEX keypad allows you to enter numeric values in numeric entry fields. You enter values in the four **number bases** below:

- **Binary**
- **octal**
- **Decimal**
- **Hexadecimal**

The A through F **keys** are used for both hexadecimal and alpha character entries.

⑦ **CHS Key.** The CHS (change sign) key allows you to change the sign (\pm) of numeric variables.

⑧ **Roll Keys.** When part of the data display is off screen, the ROLL keys define which way the KNOB will move the displayed data. These keys and the KNOB roll displayed data up/down or left/right so you can view off-screen data.

⑨ **Knob.** The KNOB has four major functions depending on what menu or pop-up menu you are in. The KNOB allows you to do the following

- Move the cursor from field to field within the System Configuration and main menus.
- Roll the display left or **right** and up or down.
- Position the **cursor** on options within pop-up menus.
- Increment/decrement numeric values in numeric pop-up menus.

⑩ **Select Key.** The SELECT key allows you to open pop-up menus, choose options in them, cancel selections, and close pop-up menus. When the cursor is in a main menu (i.e. Format Specification) pressing the SELECT key either opens a pop-up, or toggles options (when there are only two options possible) in that field.

When a pop-up menu appears, the cursor will be on the current option. You use the KNOB to move the cursor to your desired option. Pressing the SELECT key tells the logic analyzer this is the option you want. This either automatically selects the option and closes the pop-up, opens another pop-up, or changes options. If the pop-up doesn't automatically close, it **will** contain the Done field. In this case you close the pop-up by placing the cursor on Done and pressing SELECT.

- ⑪ **Disk Drive.** A 3.5 inch, double-sided, double density drive. Besides loading the operating system, it allows you to store and load logic analyzer configurations and inverse assembler files.
- ⑫ **Disk Eject Button.** Press this button to eject a flexible disk from the disk drive.
- ⑬ **Indicator Light.** This light is illuminated when the disk drive is operating. Wait until this light is out before removing or inserting disks.
- ⑭ **Inputs 1 and 2.** Two BNC connectors allow the connection of oscilloscope probes and BNC cables for signal input to the oscilloscope.

Rear-Panel Controls and Connectors

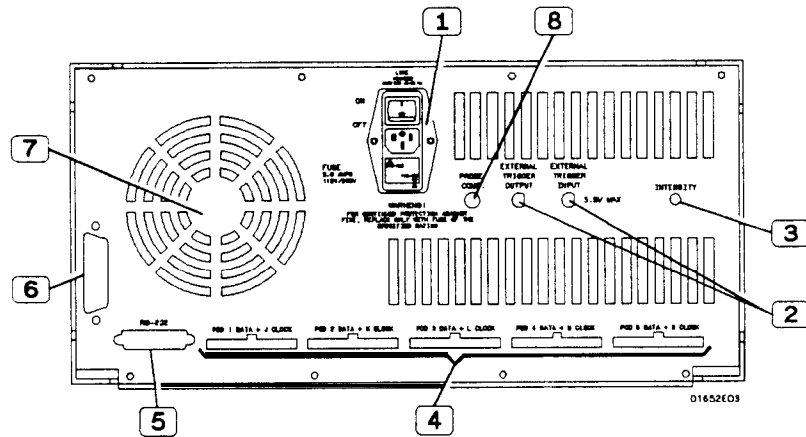

Figure 3-2. HP 1652B/53B Rear Panel

- ① **Line Power Module.** Permits selection of 110-120 or 220-240 Vac and contains the fuses for each of these voltage ranges. The On/Off switch is also part of the module.
- ② **External Trigger BNCs.** Provide arm out and arm in connections.
- ③ **Intensity Control.** Allows you to set the display intensity to a comfortable level.
- ④ **Pod Cable Connectors.** Keyed connectors for connecting the pod cables.

Note 

The HP 1653B rear panel has connectors for pods 1 and 2 only.

- ⑤ **RS-232C Interface Connector.** Standard DB-25 type connector for connecting an RS-232C printer or controller.

- ⑥ **HP-IB Interface Connector.** Standard HP-IB connector for connecting an **HP-IB** printer or controller.
- ⑦ **Fan.** Provides cooling for the logic analyzer. Make sure air is not restricted from the fan and rear-panel openings.
- ⑧ **Probe Compensation Signal Output.** Provides a signal for probe compensation adjustment.

The Cursor

The cursor (inverse video) highlights interactive fields within the menus that you want to use. Interactive fields are enclosed in boxes in each menu. When you rotate the KNOB, the cursor moves from one field to another.

How to Select Menus

You select the main menus by pressing the appropriate menu key. The main menu keys are:

- **FORMAT/CHAN**
- **TRACE/TRIG**
- **DISPLAY**
- **I/O**

When the menu is displayed, you can access fields within the menus.

The **FORMAT/CHAN**, **TRACE/TRIG**, and **DISPLAY** menu keys provide access to their respective menus. If more than one analyzer (machine) is on, or the oscilloscope is on, you see the selected menu of either analyzer 1, analyzer 2 or the oscilloscope depending on what type menu was last displayed (analyzer or scope), or what you did in the System Configuration menu. To switch from the machine 1 menu set to machine 2 (same analyzer) menu set or the oscilloscope menu set, select the desired analyzer or scope from the pop-up that appears when the **field** in the upper left corner of the main menu is selected. This pop-up is available in all main menus except the **I/O** menu.

The **I/O** menu differs from the other three main menus in that it is a pop-up menu that appears on top of the currently displayed menu when you press the **I/O** key.

How to Switch between the Analyzers and Oscilloscope

You can switch between the analyzers and oscilloscope in any main menu except the **I/O** menu. To switch between analyzers and scope, place the cursor on the field in the upper left corner of the **FORMAT/CHAN, TRACE/TRIG**, or **DISPLAY** (timing, state or scope) menu and press **SELECT**. A pop-up menu appears with the following options:

- System
- MACHINE 1 (or your analyzer name)
- MACHINE 2 (or your analyzer name)
- Mixed Mode (if **two** or more are on)
- Scope

Place the cursor on the opposite analyzer (machine), or scope and press **SELECT**. The logic analyzer will display the same menu type (i.e. format, trace, etc.) in the other analyzer (machine) or the scope menu. For example, if you were in the **TRACE** menu of machine 1, you will now see **the TRIGGER** menu of the scope or the **TRACE** menu of machine 2.

Returning to the System Configuration Menu

You can return to the System Configuration menu directly from the **FORMAT, TRACE, or DISPLAY** menus. To return to the System Configuration menu, place the cursor on the field in the upper left corner of any of these menus and press **SELECT**. The same pop-up menu appears with the following options:

- System
- MACHINE 1 (or your analyzer name)
- MACHINE 2 (or your analyzer name)
- Mixed Mode (if two or more are on)
- Scope

Place the cursor on **System** and press **SELECT**. The System Configuration menu is displayed.

How to Select Fields

You select fields **within** the main menus by placing the cursor on the desired field and pressing SELECT. Depending on what type of field you select, you will either see a pop-up menu or a new option in fields that toggle.

Pop-up Menus

The pop-up menu is the most common type of menu you see when you select a field. When a pop-up appears, you will see a list of two or more options. Two pop-up menu types are described in “How to Select Options” in this chapter.

How to Close Pop-up Menus

Pop-up menus without the Done option automatically close when you place the cursor on an option and press SELECT. After closing, the logic analyzer places your choice in the main menu field from which you opened the pop-up.

Pop-up menus that contain the Done option do not automatically close when you make your selection. To close the pop-up, you place the cursor on the Done option and press SELECT.

These **two** pop-up menu types are described in “How to Select Options” in this chapter.

How to Select Options

How to select options depends on what type of pop-up menu appears when you press select. When the pop-up appears, you will see a list of options. You select the option you want by placing the cursor on it and pressing SELECT. In most cases the pop-up menu closes and your desired option is now displayed in the field in the main menu.

There are also pop-up menus where each option within the pop-up menu has more than one option available. In these cases, when you place the cursor on one of the options and press SELECT, another pop-up will appear.

An example of one of these is the clock field in the State Format Specification menu. When you select the clock field in this menu it will pop-up and show you all five clocks (J, K, L, M, and N) for an HP 1652B or both clocks (J and K) for an HP 1653B.

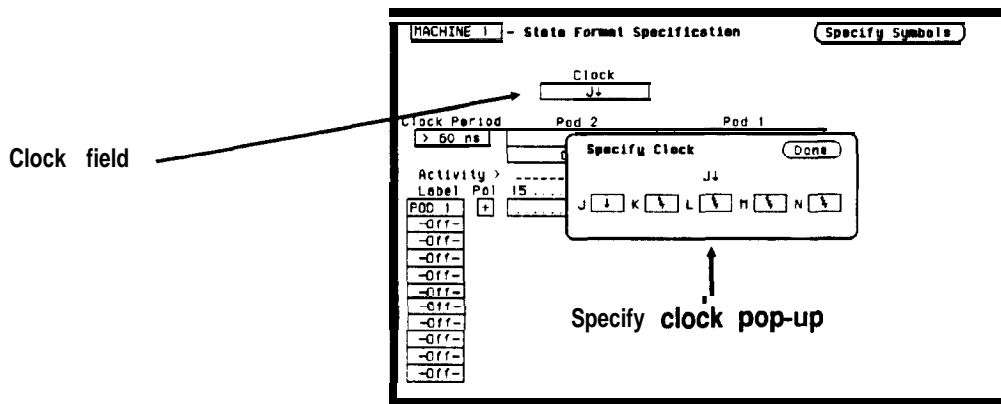

Figure 3-3. State Clock Pop-up Menu

When you place the cursor on one of the clocks and press SELECT, another pop-up appears, showing you the choices of clock specifications available.

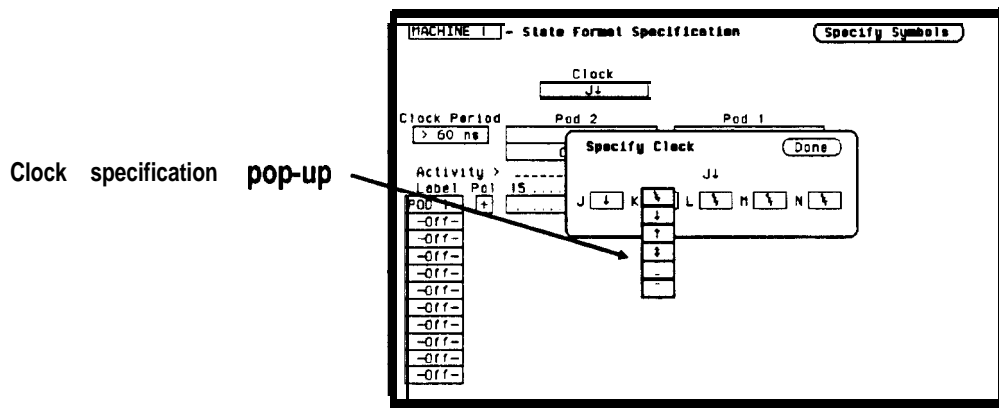

Figure 3-4. State Clock Pop-up with K Pop-up Open

When you choose one of these specifications and press SELECT, this pop-up will close, however, the original clock pop-up still remains open. When finished specifying the choices for the clocks, you close the original pop-up menu by selecting Done and pressing SELECT.

Toggle Fields

Some fields will toggle between two options “off” and “on”. When you place the cursor on one of these fields and press SELECT, the displayed option toggles to the other choice and no additional pop-up appears.

How to Enter Numeric Data

There are a number of pop-up menus in which you enter numeric data. The two major types are as follows:

- Numeric entry with **fixed** units (i.e. volts).
- Numeric entry with variable units (i.e. ms, μ s, etc.).

An example of a numeric entry menu in which you only enter the value with fixed units is the pod threshold pop-up menu.

You can set the pod thresholds to either of the preset thresholds (TTL or ECL) or to a specific voltage from -9.9 V to +9.9 V.

To set pod thresholds to a specific voltage, place the cursor in the threshold portion of the pod field (**TTL**, **ECL**, or **User-defined**) of any pod and press **SELECT**.

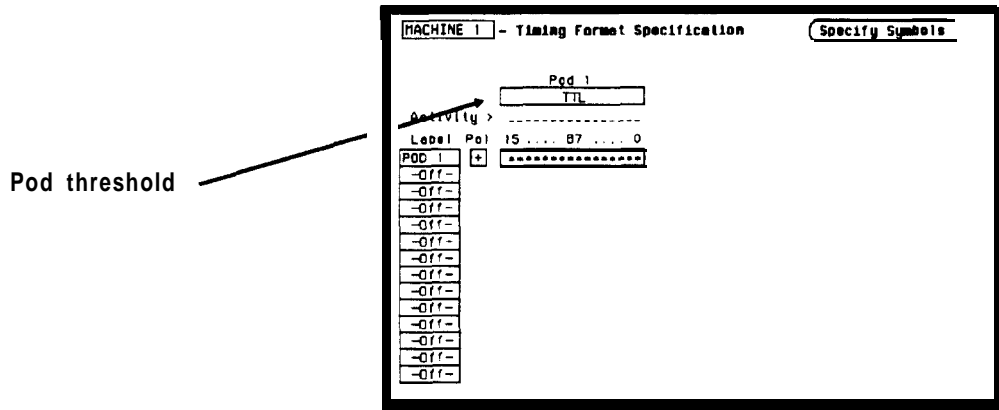

Figure 3-5. Pod Threshold

Select **the User-defined** option and another pop-up appears for you to specify the pod **threshold** voltage.

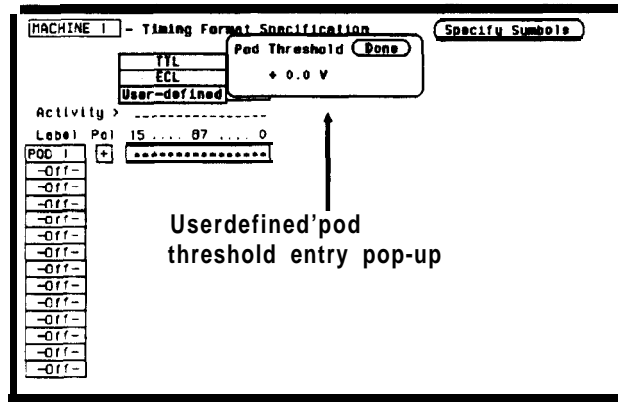

Figure 3-6. User-Defined Pop-up

You can select your desired threshold by rotating the **KNOB until your** desired threshold voltage is displayed. Rotating the KNOB increments or decrements the value in small steps. Or you can change the value with the keypad. It allows you to make large value changes **quickly**. Entering the new value from the keypad replaces the previous value.

If you want a negative voltage **for** the threshold, press the CHS (change sign) key on the front panel. The minus (-) sign will appear in the **pop-up**.

Notice, the cursor stays in the upper right corner of the pop-up over Done. When you press SELECT, the pop-up will close and your new threshold **will** be placed in the Pod field.

In another type of numeric entry pop-up menu you must specify the units as well as the numeric value. The pattern duration **specification** in the Tiig Trace Specification menu is an example. When you place the cursor on the value in the present for _____ field and press SELECT, you **will** see the following pop-up:

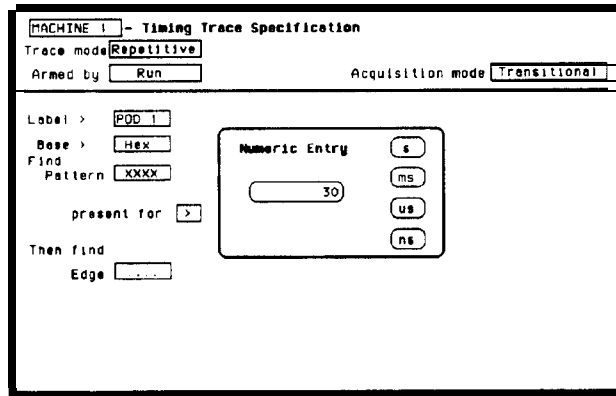

Figure 3-7. Numeric Entry Pop-up

You enter a new value from the keypad. When you have entered your desired value, you can change the units (i.e., ns, μ s, ms, s) by rotating the KNOB.

Once you select the new value and the units, close the pop-up by pressing SELECT. The new value and the units will be displayed in the **present for** _____ field.

In **all** numeric entry fields except the pod threshold field, you can open the pop-up without pressing **SELECT**. To open the pop-up without pressing **SELECT**, place the cursor on the field and press any number that particular field accepts. The pop-up will appear with the new number in the pop-up.



Any time the cursor is on one of the numeric entry fields and you unintentionally press a key that the Geld accepts, the pop-up will appear and the number you pressed will replace your current value. To close the pop-up and return the original value, press the **CLEAR ENTRY** key.

How to Enter Alpha Data

You can customize your analyzer configuration by giving names to several items:

- The name of each analyzer.
- Labels.
- Symbols.
- Filenames.
- File descriptions.

For example, you can give each analyzer a name that is representative of your measurement. The default names for the analyzers within the logic analyzer are **MACHINE 1** and **MACHINE 2**. To rename an analyzer, place the cursor on the name you wish to change in the System Configuration menu and press **SELECT**. You will see the Alpha Entry pop-up menu:

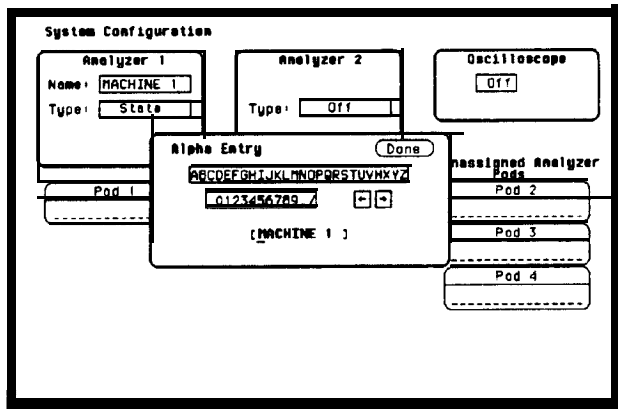

Figure 3-8. Alpha Entry Pop-up

The top two lines enclosed in boxes in the pop-up contain the complete alphanumeric set you use for names in these types of fields. The bottom line (enclosed in brackets) contains the name that existed when you opened the Alpha Entry pop-up. To enter alpha characters in the brackets (where the default or old name appears) position the cursor on the desired character and press SELECT. The new character will be placed in the brackets where the underscore marker is located. If you want to place a new character in the brackets at a location not marked by the underscore marker, move the underscore marker to where you want the new character to be placed. Moving the underscore marker is explained in “Changing Alpha Entries.”



You can also make direct keypad entries. Your selection will be placed where the underscore marker is in the box.

Changing Alpha Entries

To make changes or corrections in the Alpha Entry field, position the underscore marker under the character you want to change.

To move the underscore marker to the left, place the cursor over the left arrow and press SELECT **once** for each backspace.

To move the underscore marker to the right, you either place the cursor on a desired character and press **SELECT**, or place it on the right arrow and press **SELECT**.

You can also use the **ROLL** keys and the **KNOB** to move the underscore marker. To use this alternate method press the left/right **ROLL** key and rotate the **KNOB** until the underscore marker is under the desired character. To return the **KNOB** to controlling the cursor's movement, press the left/right **ROLL** key again or press **SELECT**.

If you want to erase the entire entry and place the underscore marker at the beginning of the name box, press the **CLEAR ENTRY** key on the front panel.

If you want to replace a character with a space, place the underscore marker under that character and press the **DON'T CARE** key on the front panel.

How to Roll Data

To roll data, you press either the left/right or up/down **ROLL** keys and rotate the **KNOB**. The roll function is only available when there is more data in the menu than can **fit** on screen. If there is off-screen data, pressing the **ROLL** keys causes an indicator to appear in the upper left corner of the display and activates the roll function of the **KNOB**. If there is no off-screen data, the indicator will not appear.

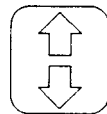

Up/Down

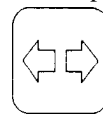

Left/Right

01550406

Figure 3-9. Roll Function Keys

One example of a menu with off-screen data is the **STATE LISTING** menu. The state listing can contain up to 1024 lines; however, the display is only capable of showing you 16 lines at a time. To roll the off-screen data, press the up/down **ROLL** key and then rotate the **KNOB** to view the off-screen data.

Label	ADDR	DATA
Base	Hex	Hex
-0007	0088C4	4E75
-0006	0088C6	61E6
-0005	0004F0	0000
-0004	0004F2	88C8
-0003	0088C8	803C
-0002	0088CA	00FF
-0001	0088CC	6730
+0000	000000	0000
+0001	000002	04FC
+0002	000004	0000
+0003	000006	8048
+0004	00B048	2E7C
+0005	00B04A	0 0 0
+0006	00B04C	04FC
+0007	00B04E	6108
+0008	008050	6100

Figure 3-10. Typical State Listing Menu

Assignment/ Specification Menus

There are a number of pop-up menus in which you assign or specify what you want the logic analyzer to do. The basic menus of this type are as follows:

- Assigning pod bits to labels
- Specifying patterns
- Specifying edges

Assigning Pod Bits to Labels

The bit assignment fields in both state and timing analyzers work identically. The convention for bit assignment is as follows:

- (asterisk) indicates assigned bits
- (period) indicates **un-assigned** bits

Note 3

If you don't see any bit assignment fields, it merely means you do not have any pods assigned to this analyzer. Either switch analyzers or assign a pod to the analyzer you are working with.

To assign bits in these menus, place the cursor on one of the bit assignment fields and press SELECT. You will see the following pop-up menu:

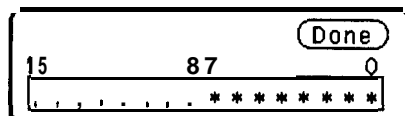

Figure 3-1 1. Bit Assignment Pop-up

Place the cursor on the left-most asterisk or period in the pop-up that you want to change and press SELECT. The bit assignment toggles to the opposite state of what it was when the pop-up first opened. Move the cursor one bit to the right. Holding the SELECT key, repeats the bit assignment. You close the pop-up by placing the cursor on Done and pressing SELECT.

Specifying Patterns

The Specify Patterns fields appear in several menus in both the timing and state analyzers. Patterns can be specified in one of the available number bases, except ASCII.

The convention for "don't cares" in these menus is an "X" except in the decimal base. If the base is set to decimal after a "don't care" is specified, a \$ character is displayed.

An example of a Specify Patterns field is the Find **Pattern**_____ field in the Timing Trace Specification menu.

When you place the cursor on the **Find Pattern** _____ field and press **SELECT**, you will see the following pop-up menu appear.



Figure 3-12. Find Pattern _____ field Pop-up

When the pop-up is open, enter **your** desired pattern from the keypad (including don't cares). When you **finish** entering your pattern, close the pop-up by pressing **SELECT**.

Specifying Edges

You can select positive-going (↑), negative-going (↓), or either edge (↑↓) as part of your trigger specification. You specify edges in the Timing Trace Specification menu by placing the cursor on the **Then find Edge** field under the desired label and pressing **SELECT**. You will see the following menu.

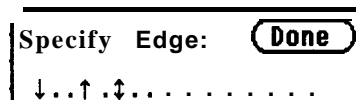

Figure 3-13. Edge Pop-up

You will notice a number of periods in the pop-up menu. Each period represents an unassigned bit for each bit assigned to the label. Don't be alarmed if you see a different number of unassigned bits, it merely means the number of bits in your label is different than the number in the label for this example.

To select a desired edge, place the cursor on your desired bit position in the pop-up and press **SELECT** until you see the desired edge, or unassign (.) the bit. Pressing **SELECT** changes the bit sequentially from (.) to ↓ to ↑ to ↑↓ and back to (.).

System Configuration Menu

Introduction

This chapter describes the System Configuration menu and pop-up menus within the System Configuration menu.

The purpose and functions of each field are explained in detail, and we have included illustrations and examples to make the explanations clearer.

System Configuration Menu

The System Configuration menu can be considered a system level menu in that it contains fields that you use to turn the scope on or off and start the configuration process for both analyzer 1 and analyzer 2. You use this menu to do the following:

- Turn analyzer machines and scope on or off.
- **Specify** analyzer type (timing and state).
- Assign pods to the individual machines within the logic analyzer.
- Initiate Autoscale in both the oscilloscope and timing analyzer.
- Name each analyzer.

In this menu, you configure your logic analyzer in one of nine ways:

- Timing analyzer only.
- State analyzer only.
- Up to two scope channels.
- Two state **analyzers**.
- One timing analyzer and one state analyzer.
- Timing analyzer with up to two scope channels.
- State **analyzer with** up to two scope channels.
- Two state analyzers with up to two scope channels.
- One timing analyzer, one state analyzer and up to two scope channels.

The System **Configuration** menu for the HP 1652B Logic Analyzer is shown below.

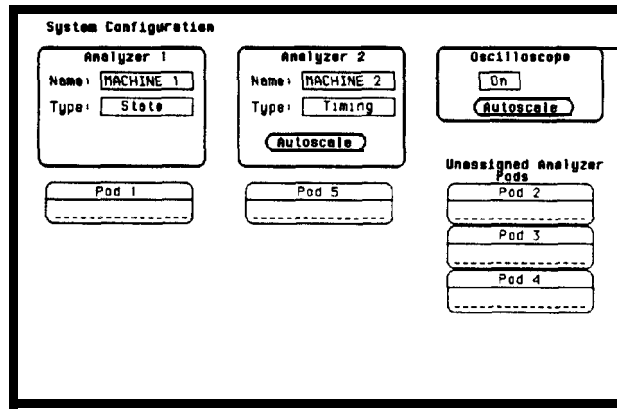

Figure 4-1. System Configuration Menu For HP 1652B

Accessing the System Configuration Menu

The System Configuration menu is the default display when the logic analyzer is turned on and the operating system has loaded. Once the logic analyzer or scope is on and you are in a menu other than the System Configuration menu, you access the System Configuration menu by placing the cursor in the system access **field** in the upper left corner and press SELECT. This field will be displaying either the scope, Machine 1, Machine 2, or a user-defined name for the current analyzer machine before you press SELECT.

You then place the cursor on System in the pop-up menu and press SELECT. When the pop-up closes the System Configuration menu will be displayed.

System Configuration Menu Fields

The System Configuration menu fields are described in the following paragraphs.

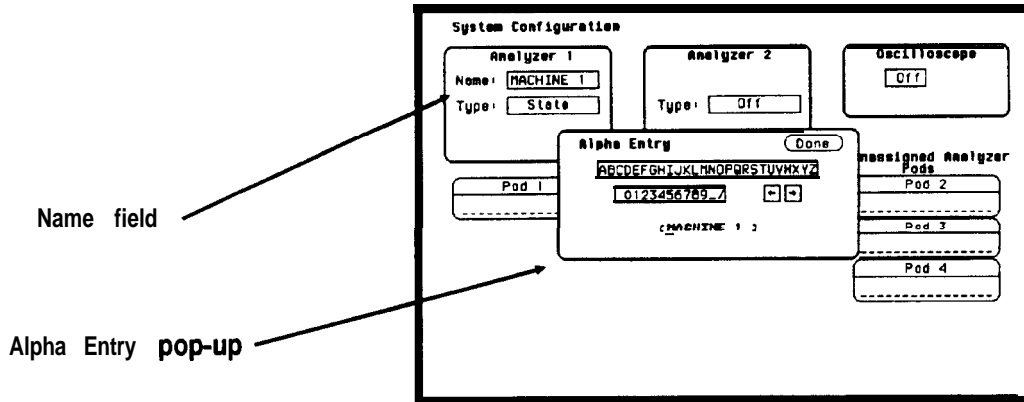

Figure 4-2. Alpha Entry Pop-up Menu

Name You name an analyzer by selecting the **Name** field under it. An Alpha Entry pop-up menu will open as shown above. The pop-up contains a row of alpha characters, a row of numeric characters, two arrows, and a box at the bottom of the menu in which the name appears. In the name box is an underscore marker. This marker indicates in what space your next selection will be placed.

You can name the analyzer in one of two ways. The first way is to position the cursor over the desired character in the pop-up using the KNOB, then press SELECT. The character appears in the name box.

The second method is to use the keypad on the front panel. With this keypad you can enter the letters A through F and the numbers 0 through 9 instead of using the characters in the pop-up.

The arrows in the pop-up move the underscore marker forward or backward. To move the marker forward, position the cursor over the right-pointing arrow and press SELECT. To backspace the marker position the cursor over the left-pointing arrow and press SELECT.

You can also move the underscore marker with the ROLL keys and the KNOB. Pressing the left/right ROLL key activates the marker. Rotating the KNOB places the marker under the desired character.

You can replace a character with a space in one of two ways. Position the cursor over the space in the pop-up and press SELECT, or press the DON'T CARE key on the front panel.

If you want to erase the entire entry and place the underscore marker at the beginning of the name box, press the CLEAR ENTRY key on the front panel. When you have entered the correct name, position the cursor over Done and press SELECT.

Type The **Type** field defines the machine as either a state analyzer or a timing analyzer. When this field is selected, a pop-up selector menu appears. You choose the machine type by using the KNOB to move the cursor within the menu to the desired selection and pressing SELECT.

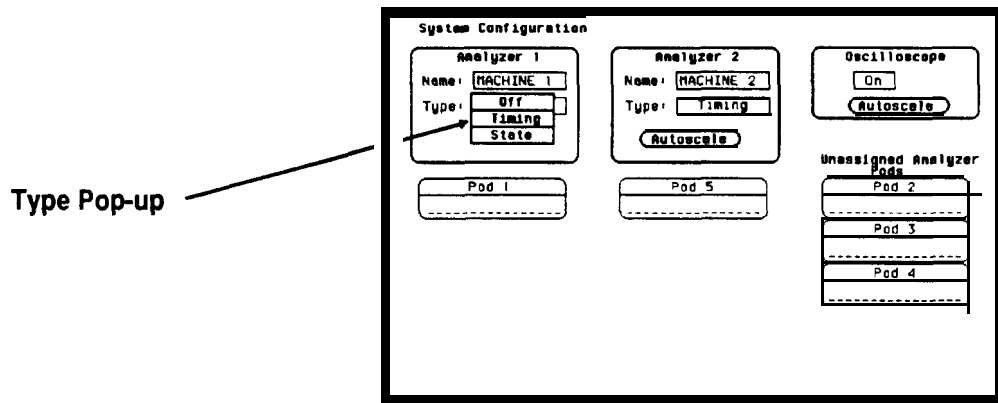

Figure 4-3. Type Pop-up Menu

Scope On/Off The scope defaults to Off. To turn the scope on or off, simply move the cursor over the On/Off field and press select. Scope measurement may be added to any analyzer configuration.

Autoscale Autoscale provides a starting point for setting up a measurement. The **Autoscale** field appears for the timing analyzer in the System Configuration menu only. When you select Autoscale, a pop-up appears with **two** options: Cancel and Continue. If you select Cancel, the autoscale is cancelled and control is returned to the System Configuration menu.

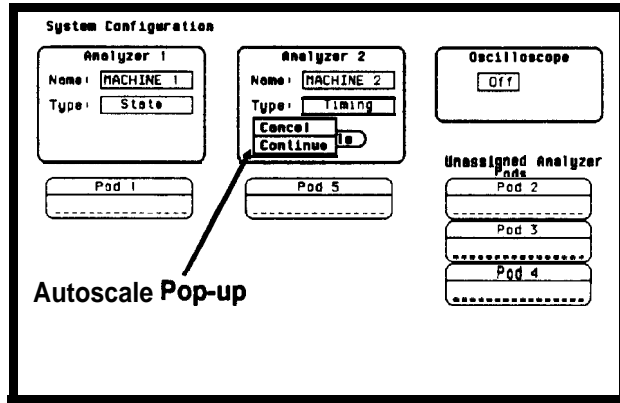

Figure 4-4. Autoscale Pop-up Menu

If you choose **Continue**, autoscale **configures** the Tii Format, Trace Specification, and the Timing Waveforms menus. Autoscale searches for channels with activity on the assigned pods and displays them in the Waveforms menu.

Autoscale for the scope is located in all main menus. When **Continue** is selected, the Channel, Trigger, and Waveforms displays are automatically **configured**. More information on scope autoscale is located in chapter 23, "Channel Menu."

Note 

Choosing Autoscale erases all previous configurations in the timing analyzer and scope, and turns the other analyzer (state) off if it was on. If you don't want this to happen, select Cancel in the pop-up.

Pods

Each pod **can be** assigned to one of the analyzers. When the HP 1652B Logic Analyzer is powered up, Pod 1 is assigned to Analyzer 1 and Pod 5 is assigned to Analyzer 2. When the HP 1653B is powered up, Pod 1 is assigned to Analyzer 1 and Pod 2 is assigned to Analyzer 2.

To assign a pod, position the cursor on one of the pod fields and press SELECT. With the pop-up that appears, you can assign the pod to Analyzer 1, Analyzer 2, or Unassign it. Pressing the SELECT key closes the pop-up.

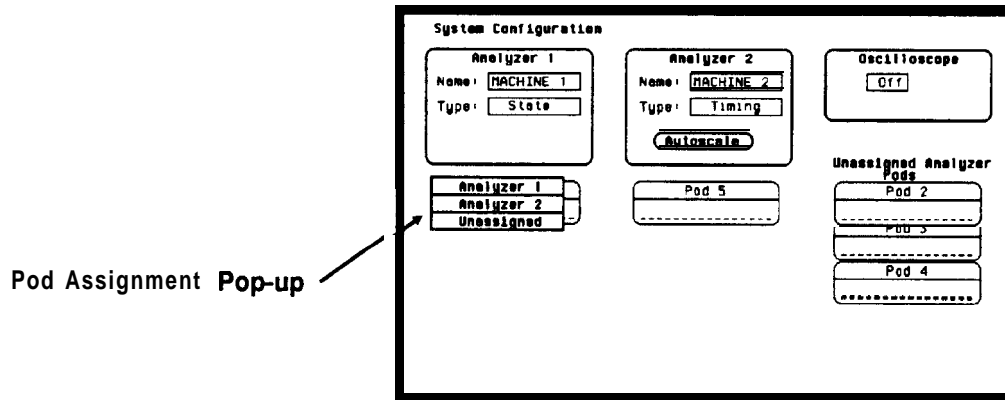

Figure 4-5. Pod Assignment Pop-up Menu

Where to Go Next

When you complete the system level configuration for the logic analyzer in this menu, you need to complete the individual analyzer configurations for analyzer 1, analyzer 2, or scope. To **configure** an individual analyzer you will normally **configure** the Format menu **first** and then the Trace menu. For the scope you configure the Channel menu first and then the Trigger menu.

Configuration menus for the timing analyzer start at chapter 16. For the state analyzer, menus start at chapter 8 and for the scope, start at chapter 22.

I/O Menu

Introduction



This chapter describes the I/O and pop-up menus that you will use on your logic analyzer. The purpose and functions of each menu are explained in detail, and we have included many illustrations and examples to make the explanations clearer.

The **I/O** menu allows you to perform I/O tasks with your logic analyzer. The tasks you can do with this menu areas follows:

- Print screens.
- Perform disk operations.
- Configure the **HP-IB** Interface.
- Configure the RS-232C Interface,
- Enable the analyzer to perform external triggering.
- Run self tests on the analyzer.

Accessing the I/O Menu

You can access the I/O menu from any other menu in the system by pressing the **I/O** key on the front panel. Use the KNOB to **roll** the cursor through the menu. When the cursor is positioned over the option you desire, press SELECT. It lists the following options:

- Done
- Print Screen
- **Print All**
- Disk Operations
- I/O Port Configuration
- External BNC Configuration
-  

To exit the I/O menu, position the cursor over the Done option and press SELECT. This returns you to the menu you were in before you pressed the I/O key.

Print Screen

When you select the **Print** Screen option, the information on the screen is frozen and the message “PRINT in progress” appears at the top of the display. This message will not print. Only the STOP key is operational while data is being transferred to the printer. If you wish to stop a printout before it is completed, press the STOP key.

Print All

The **Print All** option prints not only what is displayed on screen but what is below, and, in the Format Specification, what is to the right of the screen at the time you initiate the printout.

Note 3

Make sure the first line you wish to print is on screen when you select Print All. Lines above screen will not print.

Use this option when you want to print all the data in menus like:

- Timing Format Specification
- State Format Specification
- State Trace Specification
- State Listing
- Disk Directory
- Symbols

If there is information below the screen, the information will be printed on multiple pages. In Timing and State Format Specifications, the print will be compressed when necessary to print data that is off-screen to the right.

When you select the Print All option, the information on the screen is frozen, and the message “PRINT in progress” appears at the top of the display. This message will not print. If you wish to stop the printout before it is completed, press the STOP key on the front panel.

Disk Operations

The Disk Operations option allows you to perform operations on your disk and with the files on your disk. For example, you can load a file from your disk, store a file to your disk, or format a disk. The following pages describe the disk operations. For additional information on the disk operations, refer to Chapter 6, "Disk Drive Operations."

When you select Disk Operations, a new menu pops up. This menu is divided in **two** sections separated by a horizontal line. The top section displays the disk operation that is to be performed and the file or files that will be affected.

The bottom section displays the files on the disk in alphabetical order. It also states the type of the file and a description, if one was specified at storage. If no disk is in the disk drive or if the disk is not a supported format, the appropriate message will be displayed.

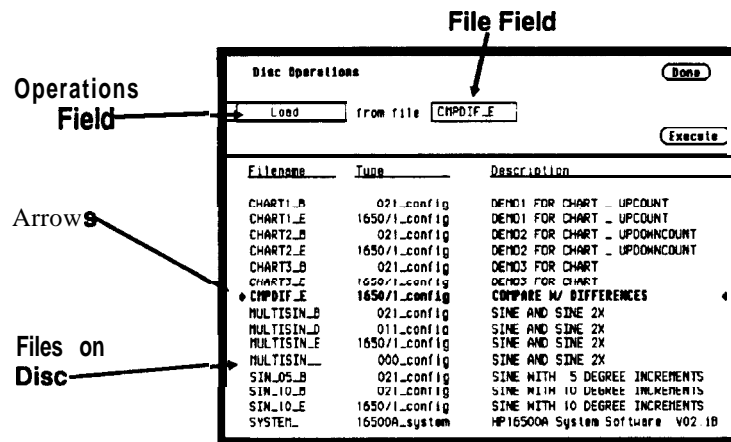

Halfway down the bottom display are arrows at each side of the screen. These arrows tell you which file is to be operated on. To roll through the list of files, press the up/down ROLL key and rotate the KNOB. The file that is between the arrows in boldface type also appears in the FILE field in the top section of the display.

The top section of the menu contains different types of fields. Pressing the Done field exits the Disk Operations menu and the I/O menu, returning you to the menu you were in before you pressed the I/O key. The field on the left-most side of the display is the operations field. It tells you which disk operation is to be performed. Next to that will usually be one or two file fields that tell you which file or files are to be acted upon. For several operations another field will appear in the top section.

The Execute field executes the disk operation appearing in the operations field. For non-destructive operations, when Execute is selected the operation is immediately performed. For destructive operations a pop-up appears with two options: Cancel and Continue. Cancel lets you change your mind before the action is taken preventing any data from being lost mistakenly. Continue executes the operation.

If you select the operations field, you will see a pop-up menu with nine options for disk operations, as shown. Each operation will now be discussed in detail.

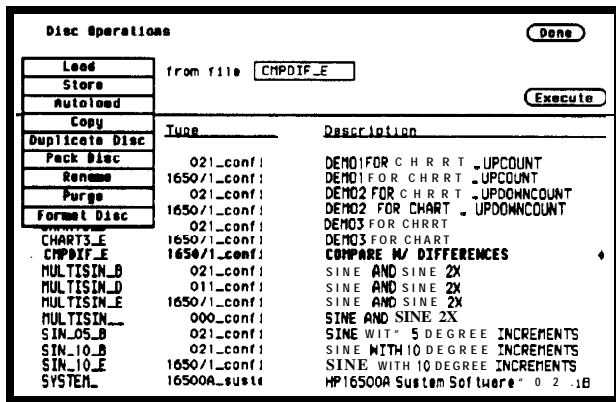

Figure 5-2. Disk Operations Pop-up Menu

Load The **Load** operation allows you to load configuration **files** (including symbol tables), and inverse assemblers from a disk. Executing a Load operation loads the logic analyzer with the file whose name appears in the File field in the top section of the Disk Operations menu. Loading symbol or inverse assembler replaces those that are linked to the current configuration.

When a Load operation is executed, a message “Loading file from disk” appears at the top of the display. After the file has been loaded, this message is replaced by “Load operation complete.”

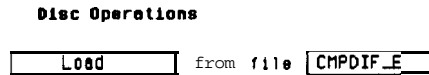

Figure 53. Load Operation

Store The Store operation allows you to store all the setup information, data and inverse assembler links for the analyzer in a configuration file. You cannot store information for only one of the internal analyzers. The information and data present in the logic analyzer at the time the Store is initiated is stored on the disk.

When you select Store from the operations pop-up **menu**, the top section of the Disk Operations menu looks similar to that shown in **figure 5-4**. In addition to the operations and **file** fields, there is a File description field. You can write an optional description of the file you are storing in this field. A **file** description is not necessary but may help identify a **file** in the future.

When you name the **file** that you are storing, you must begin the file name with a letter. The name can contain up to ten characters. It can be any combination of letters and numbers, but it cannot contain any spaces.

Entering a file description is similar to naming a file with three exceptions: you can enter up to 32 characters, start the description with a number, and enter spaces.

When you Execute the Store operation, the message “Storing **configuration** to disk” appears at the top of the display. After the file has been stored, the message is replaced with “Store operation complete” and the **file** name appears in the bottom section of the Disk Operations menu with its file type and a description, if you gave it one.

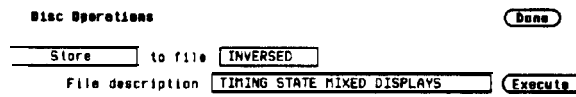

Figure 54. Store Operation

Autoload

The **Autoload** operation allows a specified configuration **file** to be loaded at power up. When you select Autoload, the top section of the Disk Operations menu looks similar to that shown below. A field appears next to the operation field. When you select this field, a pop-up menu appears with the choices Enable and Disable. Enable causes the specified file to be automatically loaded at power up. Disable prevents any file from being loaded at power up.

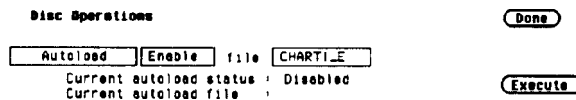

Figure 6-5. Autoload Operation

The **file** name in the **file** field can be changed with one of two methods. One method is to press the up/down ROLL key and rotate the KNOB to scroll through the list of files until the name of the desired file appears in the file field. The other method is to select the **file** field and use the Alpha Entry pop-up menu and the front-panel keypad to enter the name.

Below the operations and file fields are two information lines. The **first** line indicates the status of **autoload** (Enable or Disable), and the second line tells you which file, if any, is enabled for autoload. When you select either Enable or Disable the **autoload** status of a file will not change until you select Execute.

When you select Execute, after selecting Enable, the file whose name appears **in** the file field is selected for autoloading. The **autoload** status line will say Enable, and the **autoload** file line will state the name of the **file**.

Also, a tile labeled **AUTOLOAD** is added to the bottom section of the display. This **file** is not a configuration file. It contains information the logic analyzer needs to load the chosen file at power up. If you disable autoloading, the tile labeled **AUTOLOAD** does not disappear. You must Purge it to erase it from your disk. The Purge disk operation is covered later in this chapter. If **Autoload** is disabled, the logic analyzer will load the default configuration at power up.

Copy The Copy operation allows you to copy a **file** to the same disk or to another disk. When you select Copy, the top section of the Disk Operations menu will look similar to that below.

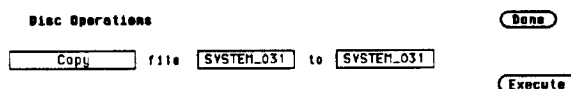

Figure 5-6. Copy Operation

Notice that there are two **file** fields. You can specify the **file** you are copying from and the **file** you are copying to. When you select either file field, you will get an Alpha Entry pop-up menu. You can use this menu and the keypad on the front panel to enter the name of the file. For the **file** that you are copying from, it is usually easier to use the up/down ROLL key and the KNOB to select one of the files on the disk rather than to use the Alpha Entry menu.

When you select Execute you will see a pop-up that tells you to insert the disk onto which you want to copy the file. There are also two fields in the pop-up. One is labeled Continue. You select Continue after you have inserted the disk and are ready to copy the file. The other field is labeled **Stop. Selecting the** Stop field halts the copy and returns you to the Disk Operations menu.

If you insert the destination disk and select **Continue**, the file will be copied. If the file is long, you might have to swap the source and destination disks again. The logic analyzer tells you if you need to reinsert the source disk to continue copying the file. You can also copy to the same disk, making the source and destination disk the same.

Duplicate Disk

The Duplicate Disk operation allows you to duplicate all the **files** on one disk to another. When you select this option, only the operations field appears in the top section of the Disk Operations menu. The disk is automatically formatted in this operation.



Figure 5-7. Duplicate Disk Operation

When you select Execute, you will see a pop-up with a message telling you what occurs when a disk is duplicated. The pop-up also contains **two** fields: Cancel and Continue. Cancel stops the duplicating process and returns you to the Disk Operations menu. Continue executes the operation. If you select Continue, the display goes blank except for the message "Insert source disk - hit select when ready." Insert the disk you want to duplicate and press SELECT. After the logic analyzer reads the disk, it displays the message "Insert destination disk - hit select when ready." Insert the disk to which you want to copy and press SELECT. The analyzer will tell you that it's writing to the disk.

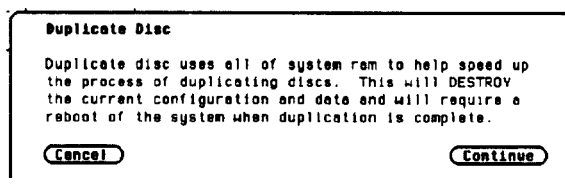

Figure 58. Duplicate Disk Pop-up Menu

The process of duplicating a disk is an iterative one; i.e., more than one swapping of disks may be necessary before all files are transferred. If this is the case the logic analyzer will repeat the message telling you to insert the source disk. Insert the source disk and press SELECT. The analyzer remembers where it stopped duplicating the first time and starts reading from that location. When the analyzer is ready, insert the destination disk and press SELECT. You will never have to swap disks more than three times.

After the duplication process is complete, the logic analyzer displays a message telling you what to **do next**. If you want to copy another disk, press the **FORMAT** key on the front panel. The analyzer will repeat its message to insert the source disk. If you do not want to copy any more disks, insert the system disk and press the **SELECT** key. This reboots the system.

Note 

Duplicating a disk destroys any existing configurations and data on the destination disk. Make sure that the disk to which you are duplicating is the correct disk.

Pack Disk

The Pack Disk operation reorganizes the files on the disk, making room for more. When a file is purged, it is not removed from the disk even though it doesn't appear in the Disk Operations menu. Packing a disk moves files up, creating space at the bottom of the disk memory.

When you select Pack Disk, the top section of the Disk Operations menu looks similar to that shown below. Selecting Execute starts the process. After the packing is completed, the message "Disk packing complete" appears at the top of the screen.



Figure 5-9. Pack Disk Operation

Rename

The Rename operation lets you rename a file. When you select this option, the display will look similar to that shown in figure 5-10.

You will see a **file** field that tells you what the old name of the **file** is, and a **file** field that tells you what the new name will be. If you select either one of the file fields, an Alpha Entry pop-up menu appears. You can use this menu and the keypad on the front panel to enter the name of the file. For the field with the old **file** name, it is usually easier to use the up/down **ROLL** key and the **KNOB** to select the desired **file** rather than to use the Alpha Entry pop-up menu.

To start the rename operation, select Execute. The file will be renamed and relocated alphabetically in the **file** list in the bottom section of the Disk Operations menu.

If you try to rename a file with a name that already exists, a message will tell you that a **file** already exists with **that** name, and the file will not be renamed.

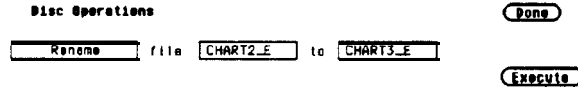

Figure 5-10. Rename Operation

Purge The Purge operation allows you to delete a **file** from a disk. When you select this option, the display will look similar to that shown below.

The file field contains the name of the file to be purged. You can change the file in this field either by positioning the cursor on the field and selecting it to access an Alpha Entry pop-up menu, or by using the up/down ROLL key and the KNOB to move among the files.

When you select Execute you will see a pop-up with the choices **Cancel** and **Continue**. Cancel lets you stop the Purge operation and returns you to the Disk Operations menu. Continue purges the file whose name appears in the file field.

Note 3

A purged file cannot be recovered. Make sure the file that is being purged is the correct one.

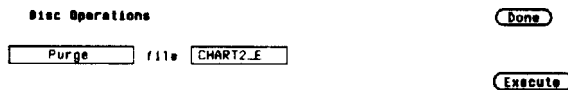

Figure 5-1 1. Purge Operation

Format Disk

The Format Disk operation formats a disk, purging all previous files on the disk. When you select this option, the display will look similar to that shown in figure 5-12.

Selecting Execute gives you a pop-up with the choices Cancel and Continue. Cancel stops the format operation and returns you to the Disk Operation menu. If you select Continue, the disk will be formatted. The message “Disk format in progress” will appear at the top of the screen. When the formatting is complete, all the files will be deleted.



Formatting a disk purges all the files on the disk. Make sure the disk is the correct one to be formatted because purged files cannot be recovered.



Figure 6-12. Format Disk Operation

I/O Port Configuration

The I/O Port Configuration option in the I/O menu enables you to configure the logic analyzer for sending **configuration**, waveforms and listings to a printer or controller via **HP-IB** or RS-232C.

When you place the cursor on the External I/O Configuration option and press SELECT, you will see the menu shown in figure 5-13.

```
External I/O Port Configuration [Done]
Printer connected to [RS-232-C] Controller connected to [HP-IB]

RS-232-C Configuration          HP-IB Configuration
Protocol : [XON/XOFF]          HP-IB Address : [7]
Stop Bits : [1]
Parity : [None]
Baud rate : [2400]
Data Bits : [8]

Printer Information
Printer : [LaserJet] Paper width : [8.5"]
```

Figure 513. External I/O Port Configuration Menu

The HP 1652B/53B is equipped with a standard RS-232C interface and an HP-IB interface that allows you to connect to a printer or controller. Connecting a controller gives you remote access for running measurements, up-loading and down-loading configurations and data, and outputting to a printer. The controller interface is explained in more detail **in the HP 1652B/1653B Programming Reference Manual**.

Various HP-IB and RS-232C graphics printers can be connected to the logic analyzer. Configured menus as well as waveforms and other data can be printed for complete measurement documentation. The printer interface is explained in more detail in Chapter 7.

Configuring the Interfaces

You configure the HP-IB or RS-232C interfaces for a controller or a printer by first selecting the I/O menu. Then you select the **I/O Port Configuration** field to display the **External I/O Port Configuration** menu. When the menu appears, select either field at the top of the menu to switch the interfaces between a printer and a controller. Whenever you change the configuration for one interface, the other interface automatically changes to the opposite configuration.



Figure 6-14. Interface Configurations

The **HP-IB** printer must be set to **Listen** Always for the HP-IB interface. In this mode, no **HP-IB** addressing is necessary. There are two fields at the bottom of the menu that allow you to select the printer type and paper width.

The HP-IB interface

The Hewlett-Packard Interface Bus (HP-IB) is Hewlett-Packard's implementation of IEEE Standard 488-1978, "Standard Digital Interface for Programmable Instrumentation." The HP-IB is a carefully defined interface that simplifies the integration of various instruments and computers into systems. It uses an addressing technique to ensure that each device on the bus (interconnected by HP-IB cables) receives only the data intended for it. To accomplish this, each device is set to a different address and this address is used to communicate with other devices on the bus.

Selecting an Address. The HP-IB address can be set to 32 different HP-IB addresses, from 0 to 31. Simply choose an address that is compatible with your device and/or software. The default is 7.

To select an address:

1. Select the External I/O Port **Configuration** menu and place the cursor in the field directly to the right of **HP-IB Address:**. Press **SELECT** and an Integer Entry pop-up appears. See figure 5-15.

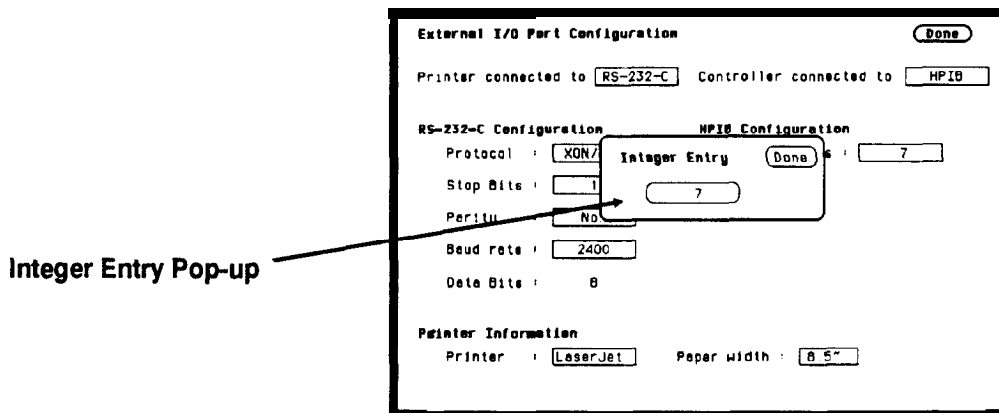

Figure 5-15. Integer Entry Pop-up

2. When the pop-up appears, either rotate the knob or use the keypad to enter the address. If you enter an address greater than 31, the address will default to 31 when you select **Done**.
3. When you are **finished** entering the HP-IB address, select **Done**. The pop-up closes, placing your selection in the appropriate field.

The RS-232C Interface

The RS-232C interface is Hewlett-Packard's implementation of EL4 Recommended Standard **RS-232C**, "Interface Between Data Terminal Equipment and Data Communications Equipment Employing Serial Binary Data Interchange." With this interface, data is sent one bit at a time and characters are not synchronized with preceding or subsequent data characters. Each character is sent as a complete entity without relationship to other events.

Protocol. Protocol governs the flow of data between the instrument and the external device. The protocol options are None and **XON/XOFF**. The default setting is **XON/XOFF**.

None
XON/XOFF

Figure 5-16. Protocol Pop-up Menu

With less than a **5-wire** interface, selecting None does not allow the sending or receiving device to control how fast the data is being sent. No control over the data flow increases the possibility of missing data or transferring incomplete data. With a full **5-wire** interface, selecting None allows a hardware handshake to occur. With a hardware handshake, hardware signals control data flow. The HP **13242G** cable allows the HP **1652B/1653BA** to support hardware handshake.

With **XON/XOFF**, the receiver controls the data flow. By sending XOFF (ASCII **decimal 19**) over its transmit data line, the **receiver** requests that the sender disables data transmission. A subsequent XON (ASCII decimal 17) allows the sending device to resume data transmission

Data Bits. Data bits are the number of bits sent and received per character that represent the binary code of that character. The HP **1652B/53B** supports **8-bit** only.

Stop Bits. Stop bits are used to identify the end of the character. The number of stop bits must be the same for both the controller and the logic analyzer. The options are **1, 1.5,** or 2 stop bits per character. The default setting is 1.

1
1 1/2
2

Figure 5-17. Stop Bits Pop-up Menu

Parity. The parity bit detects errors as incoming characters are received. If the parity bit does not match the expected value, the character is assumed to be incorrectly received. The action taken when an error is detected depends on how the interface and the device program are configured.

Parity is determined by the requirements of the system. The parity bit may be included or omitted from each character by enabling or disabling the parity function. The options are **None**, **Odd**, or **Even**. The default setting is **None**.

None
Odd
Even

Figure 5-18. Parity Pop-up Menu

Baud Bate. The baud rate is the rate at which bits are transferred between the interface and the peripheral. The baud rate must be set to transmit and receive at the same rate as the peripheral, or data cannot be successfully transferred. The available baud rates are 110 to 19.2k. The default setting is 9600.

110
300
600
1200
2400
4800
9600
19200

Figure 5-19. Baud Rate Pop-up Menu

Printer. You can specify which printer you are using by selecting the Printer attribute field and choosing one of the options in the pop-up. The options are **ThinkJet**, **QuietJet**, **LaserJet**, and **Alternate**. Alternate allows you to use an Epson[®] compatible printer. The default printer option is **ThinkJet**.



Figure 5-20. Printer Pop-up Menu

Paper Width. The logic analyzer offers two options for paper width: 8.5 and 13.5 inches. Selecting the **Paper Width** attribute field gives you a pop-up with which you can make your choice.

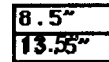

Figure 5-21. Paper Width Pop-up Menu

The HP Thiiet and HP LaserJet series printers require a paper width of 8.5 inches and the HP **QuietJet** series printers require a paper width of 13.5 inches. If you have an HP **ThinkJet** or HP LaserJet printer but have set the paper width to 13.5 inches, the logic analyzer tells the printer to compress the print so it will fit on a page. The results may not be satisfactory. If you have an Epson@ compatible printer, check your printer manual to see which size is required.

External BNC Configuration

On the rear panel of the logic analyzer are two BNC connectors. One BNC is an input for an external trigger source. The other is used to output a trigger source. The **External BNC Configuration** option in the I/O menu identifies one of the two internal machines or scope to be the trigger source for an external instrument.

When you select this option you will see a field next to the words "BNC output armed by." Selecting this field gives you a pop-up with either two or three options. One option is Off. This indicates that the logic analyzer will not trigger an external instrument. The other options are the internal analyzers, listed by name. You can select the analyzer for triggering your external instrument by using the **KNÖB** to position the cursor on the appropriate name and pressing **SELECT**.

If for some reason both of the internal analyzers are off, selecting the **External BNC Configuration** option gives you the message “BNC output armed by : Off (note: both machines are off).”

Self Test

The **Self Test** option in the **I/O** menu allows you to run a self test on the logic analyzer. The self test is on the PV disk. Selecting this option gives you a pop-up telling you what effect the self test has on the analyzer. The pop-up also contains two fields: **Cancel** and **Start Self Test**. **Cancel** lets you change your mind about running the self test. Selecting this field returns you to the **I/O** menu. Selecting the **Start Self Test** field causes your logic analyzer to load the self test from the disk and run through it. Before selecting this field you must insert the master disk with the self test on it.



Running the self test destroys all current configurations and data. **Make** sure that you save any important configurations on a disk before running any of the self tests.

For a description of the individual self **tests**, refer to appendix E, in volume 2 of this manual.

Disk Drive Operations

Introduction

This chapter describes the disk operations of the HP 1652B/53B in a task format. The disk operations are described in detail in chapter 5.

The Disk Operations Available

Nine disk operations are available:

- **Load** • Instrument configurations and data can be loaded from the disk. Inverse assemblers can be loaded.
- **Store** • Instrument configurations and data can be stored on disk. System files cannot be stored.
- **Autoload** • Designates a **configuration** file to be loaded automatically the next time the HP 1652B/53B is turned on.
- **Copy** • Any file on the **disk** can be copied from one disk to another or to the same disk.
- **Duplicate Disk** • All **files** from one disk are copied to another disk. The directory and all files on the destination disk will be destroyed with this operation. The copied files are packed on the new disk as they are copied.
- **Pack Disk** • This function packs files on a disk. Packing removes **all** empty or unused sectors between files on a disk so that more space is available for files at the end of the disk.
- **Rename** • Any filename on a disk can be changed to another name.
- **Purge** • Any **file** on a disk can be purged (deleted) from the disk.
- **Format Disk** • Any two-sided **3.5-inch** floppy disk can be formatted or initialized. The directory and all files on the disk will be destroyed with this operation.

Although default values are provided for these disk operations, you may have to specify additional information. This information is entered by selecting the appropriate fields displayed for each disk operation. Disk operations are initiated by selecting the Execute field. If there is a problem or additional information is needed to execute an operation, an advisory appears near the top center of the screen displaying the status of the operation (an error message prompts to swap disks, etc.).

If executing a disk operation could destroy or damage a file, another pop-up appears with the options Cancel and Continue when you select Execute. If you don't want to complete the operation, select Cancel to cancel the operation. Otherwise, select Continue and the operation will be executed.

Accessing the Disk Menu

To display the Disk Operations menu, press the I/O menu key.

When the I/O pop-up menu appears, place the cursor on Disk Operations and press SELECT. You will see the Disk Operations menu.

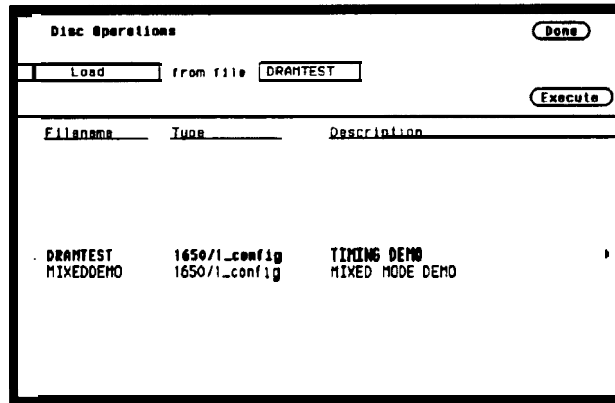

Figure 6-1. Disk Operation Menu

Selecting a Disk Operation

To select a disk operation, place the cursor on the field directly below Disk Operations and press SELECT. You will see the following pop-up:

Load
Store
Autoload
Copy
Duplicate Disc
Pack Disc
Rename
Purge
Format Disc

Figure 6 - 2. Disk Operations Pop-up Menu

When the pop-up appears, place the cursor on the operation you want and press SELECT. After you select an option, the pop-up closes and displays the fields required for your operation. For example, select Store. The Disk Operations menu now looks like this:

Filename	Type	Description
• DRATEST	1650/1_config	TIMING DEMO
MIXEDEMO	1650/1_config	MIXED MODE DEMO

Figure 63. Store Operation

Disk Operation Parameters

The disk operation parameters consist of the information that the disk operation acts upon. They tell the logic **analyzer** the names, types, and descriptions of files. To change these parameters, select the appropriate field and the field will either toggle to the opposite function or a pop-up will appear. If a pop-up appears, select the appropriate option or enter data with the keypad.

To initiate the disk operation function you have selected, place the cursor on Execute. A pop-up appears with Continue and Cancel. To continue, place the cursor on Continue and press SELECT. To cancel place the cursor on Cancel and press SELECT. The Autoload, Pack Disk, and Rename functions immediately execute because they are not destructive to the files. These functions do not give you the Cancel and Continue options.

The screenshot shows a menu titled "Disc Operations" with a "Done" button in the top right. Below the title is a "Copy" button, followed by the text "file" and a field containing "DRANTEST", then "to" and another field containing "DRANTEST". To the right of this section is an "Execute" button. Below these elements is a table with three columns: "Filename", "Type", and "Description".

Filename	Type	Description
• DRANTEST	1650/1_config	TIMING DEMO
MIXEDDEMO	1650/1_config	MIXED MODE DEMO

Figure 64. Disk Operation Parameters

Installing a Blank Disk

Included with the HP 1652B/53B is a blank 3.5-inch flexible disk for your own use. To **install** the blank disk, hold the disk so that the Hewlett-Packard label is on top and the metal auto-shutter is away from you. Push the disk gently, but firmly, into the front disk drive until it clicks into place.

Note

The HP 1652B/53B disk drives use the **gray** Hewlett-Packard double-sided disks, which can be ordered in a package of ten with the Hewlett-Packard part number 92192A. DO NOT use single-sided disks with the HP 1652B/53B.

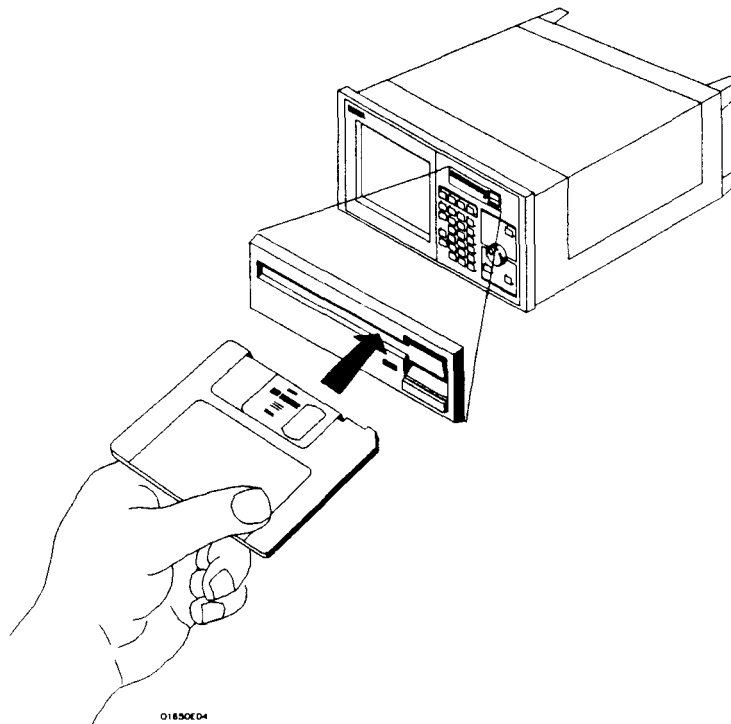

Figure 6-5. Installing a Disk

Formatting a Disk

Before any information can be stored on a new disk, you must first format it. Formatting marks off the sectors of the disk and creates the LIF (Logical Interchange Format) directory on the disk. If you initiate a Duplicate Disk operation, the logic analyzer will automatically format the destination disk.

Note

The HP 1652B/53B does not support track sparing. If a bad track is found, the disk is considered bad. If a disk has been formatted elsewhere with track sparing, the HP 1652B/53B will only read up to the first spared track.

Select the Format Disk operation.

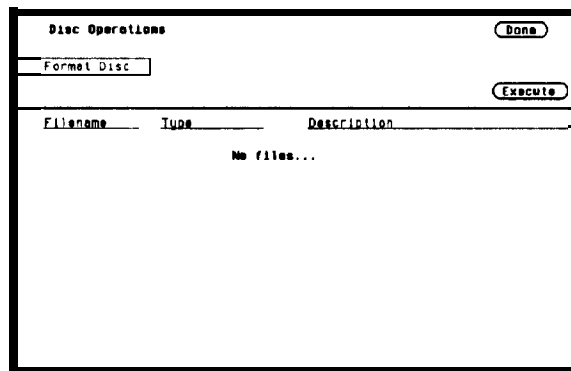

Figure 6-6. Format Disk Operation

After the Format Disk operation menu appears, the instrument reads the disk and shows its condition. One of three conditions can exist:

- If this is a new disk, or a disk formatted by a disk drive not using the LIF format, the menu will display UNSUPPORTED DISK FORMAT on the lower portion of the menu.
- If the disk is already formatted, but has no files, the menu will display No Files.

- If the disk already has files, a list of file names appear on the lower portion of the menu along with a file type **and description**.

If any of the listed files need to be saved, copy them to another disk before initiating the Format Disk function. To initiate the Format Disk function, select Execute. When the pop-up appears, select Continue and the instrument will format the disk. Otherwise, select Cancel to cancel the Format Disk operation.

Caution 

Once you press Continue, the Format Disk operation starts and permanently erases all the existing information from the disk. After that, there is no way to retrieve the original information.

Storing to a Disk

The Store operation allows you to store your configurations and data to a **file** with a description of its contents. You must assign a file name for each file in which you wish to store data.

Select the Store operation.

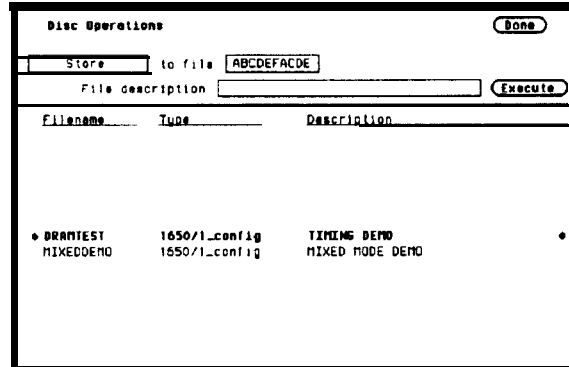

The screenshot shows a terminal window titled "Disc Operations" with a "Done" button in the top right. Below the title bar, there are two input fields: "Store" followed by "to file" and a field containing "ABCDEFACDE". Below that is a "File description" field which is empty, followed by an "Execute" button. At the bottom of the window is a table with three columns: "Filename", "Type", and "Description".

Filename	Type	Description
• DRAMTEST	1650/1_config	TIMING DEMO
MIXEDEMO	1650/1_config	MIXED MODE DEMO

Figure 6-7. The Store Operation

To name your **file**, place the cursor on the field to the right of “to file” and press SELECT. The **Alpha** Entry pop-up appears.

Enter a filename that starts with a letter and contains up to ten characters. It can be any combination of letters and numbers, but there can be no blank spaces between any of the characters.

Entering a file description is the same process as naming a **file** except you can enter up to 32 characters, start the description with a number, and enter spaces between characters.



The field for “file description” makes it easier to identify the type of **data** in each file. This is for your convenience but you can leave this field blank.

When you have completed entering the file name and **file** description, you initiate the store operation by placing the cursor on Execute and pressing SELECT. A pop-up appears with Continue and Cancel. To continue, place the cursor on Continue and press SELECT. To cancel, place the cursor on Cancel and press SELECT.



If you store a new configuration and data to an existing tile, they are written over the original information “DESTROYING” the original information in that **file**.

The Load Operation

The Load operation allows you to load previously stored configuration and data from a file on the disk.

Select the Load operation.

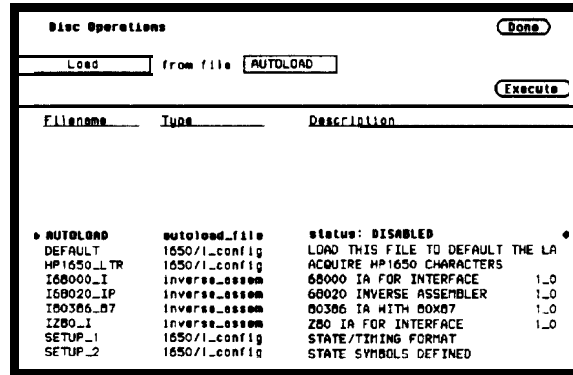

Figure 68. The Load Operation

Note



The Load operation is type dependent. This means that you cannot load a system file. For example, if you try to load the file “SYSTEM-,” an advisory “Warning: Invalid file type” appears in the top center of the display.

To load the desired file, press the up/down ROLL key and rotate the KNOB until the desired **file** appears in the field to the right of “from file.”

Another way to enter the name of the file in the **field** to the right of “from file” is to select this field. When the Alpha Entry pop-up appears, enter the correct **filename**.

Renaming a File

The **rename** operation allows you to change the name of a file. The only restriction is that you cannot rename a file to an already existing filename.

Select the Rename operation. When you have completed entering a new **file** name and description, you initiate the Rename operation by placing the cursor on Execute and pressing SELECT.

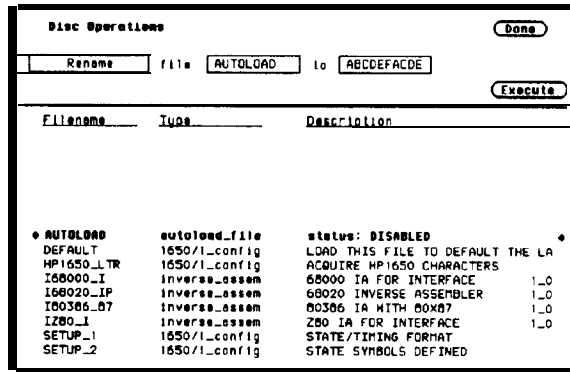

Figure 69. Renaming a File

Use either the KNOB or the Alpha Entry pop-up to enter the filename you wish to change in the field to the right of “file.”

Move the cursor to the field to the right of “to” and press SELECT. When the Alpha Entry pop-up appears, enter the new **file** name. When you have completed entering the new **file** name, you initiate the rename operation by placing the cursor on Execute and pressing SELECT. The rename operation immediately executes and when it is completed, an advisory “Rename operation complete” is displayed.

The Autoload Operation

Autoload allows you to designate a configuration file to be loaded automatically the next time the HP 1652B/53B is turned on. When the **Autoload** operation is enabled, your designated configuration file is loaded instead of the default configuration file. This process allows you to change the default configuration of certain menus to a configuration that better fits your needs.

Select the **Autoload** operation. To enable Autoload, select the Disable field and when the pop-up appears, select Enable.

With the up/down ROLL key and KNOB or the Alpha Entry pop-up enter the name of the configuration file you wish to load in the field to the right of "File" and select Execute. The **Autoload** function is Enabled as shown after "Current **Autoload** status:" on the display.



When power is applied to the logic analyzer, **Autoload** On or Off is determined by the presence of an enabled **autoload** file on the disk. If an enabled **autoload** file is present on the disk, the logic analyzer will load this configuration file instead of the standard configuration file.

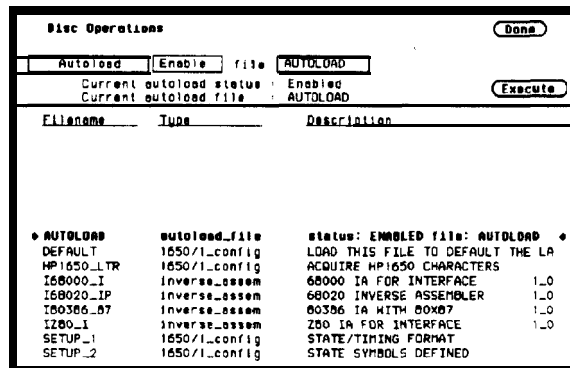

Figure 6-10. Autoload Operation Enabled

To disable the **Autoload** operation, select enable and when the pop-up appears, select disable. When the pop-up closes, select Execute and the **Autoload** function is disabled.

Purging a File

Select the Purge operation to Purge (delete) a file. With either the up/down ROLL key and KNOB or the Alpha Entry pop-up enter the **file** you wish to purge in the field to the right of "file." Select Execute and when the pop-up appears, select Continue and the file is purged **from the disk**.



Once EXECUTED, the Purge operation permanently erases the file. After that, there is no way to retrieve the original information.

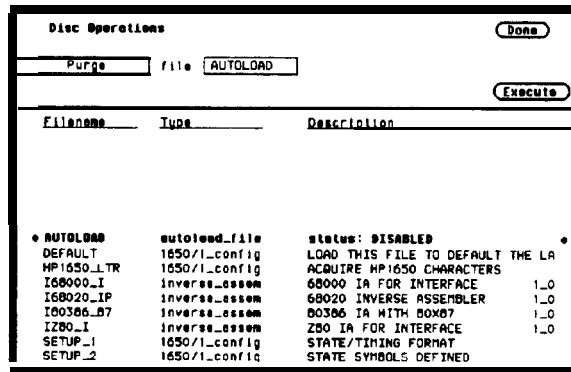

Figure 611. Purging a File

Copying a File

The Copy operation allows you to copy a **file** to the same disk or another disk. Select the Copy operation. With either the up/down ROLL key and the KNOB or the Alpha Entry pop-up, enter the filename you wish to copy in the field to the right of “file.” Select the field to the right of “to” and when the Alpha Entry pop-up appears, enter the name of the **file** you want to “copy to.”

You can also copy a **file** to the same filename on another disk. To do this, select the “To” filename field, press the CLEAR ENTRY key, place the cursor on Done and press SELECT. This copies the original filename in the “To” filename field.

Select Execute to start the copy operation. A pop-up appears with instructions on what to do with the disks. Since you can copy a file to the same disk or another disk, simply follow the instructions as they apply to your situation and select Continue to continue.

- When “Insert the source disk” appears, remove the source disk and insert the destination disk into the disk drive if you are copying the **file** to another disk. The cursor is located on “Continue,” so to continue, press SELECT; otherwise, place the cursor on “Stop” and press SELECT. If you are copying to the same disk, press “Continue” without moving the disk.

If the **file** cannot be copied in a single operation, the instruction “Insert the source disk” will appear in the pop-up. Remove the destination disk, re-insert the source disk and select Continue. The logic analyzer reads another segment of the source file. It will then tell you when to re-insert the destination disk and continue.

Note

If the source **file** is large (ie. System file) you should use the Duplicate Disk operation. Duplicating large files using the Copy operation requires changing disks many times. This invites the possibility of losing track of the disk changes, which will destroy part or all of the files on the source disk.

When the copy operation is complete, you will see the new file name in the directory. The new file name will be inserted in the directory in alphabetical order.

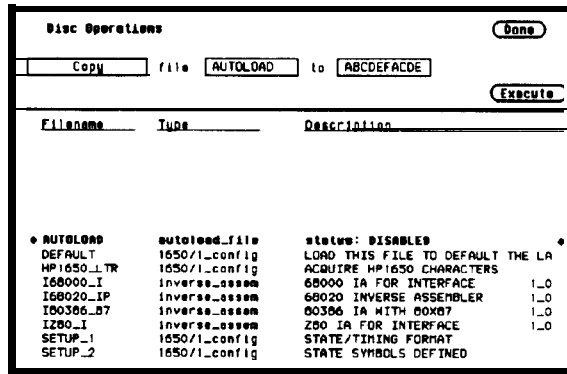

Figure 6-12. Copy File Operation

The Pack Disk Operation

By deleting **files** from the disk and adding other **files**, you end up with blank areas on the disk (between files) that are too small for the new files you are creating. The Pack Disk operation packs the current files together, removing unused areas from between the **files** so that more space is available for files at the end of the disk.

Select the Pack Disk operation. To pack the disk, select Execute.

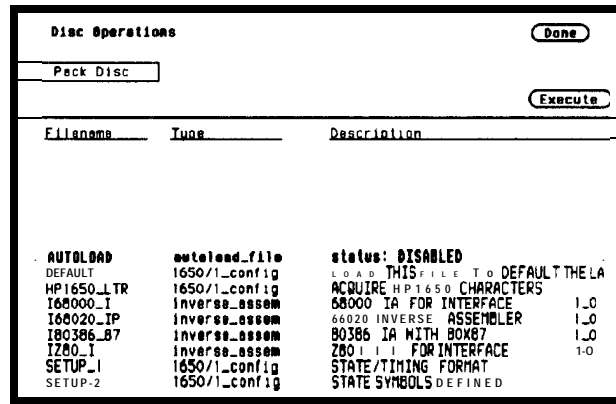

Figure 613. The Pack Disk Operation

Duplicating the Operating System Disk

The Duplicate Disk operation allows you to duplicate all the files on one disk to another disk. You use this operation to make a back-up copy of your important disks so you won't lose important data in the event the disk wears out, is damaged, or a file is accidentally deleted.

Select the Duplicate Disk operation and press Execute. When the pop-up appears you will see the following advisory.

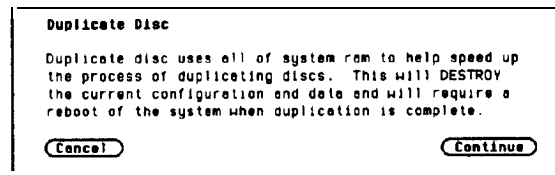

Figure 614. Duplicate Disk Pop-up

Caution

The original directory and files on the destination disk are destroyed by the DUPLICATE DISK operation.

To continue, select Continue. The instruction "Insert disk to be copied-hit select when ready" will be displayed. Insert the source disk and press SELECT. The logic analyzer reads the source disk and displays "Reading from source disk. Please wait..."

When the logic analyzer has filled memory or has read the entire source disk, it displays "Insert destination disk-hit select when ready." Remove the source disk, insert the destination disk and press SELECT. When the logic analyzer starts writing to the destination disk, you will see "Writing to destination disk. Please wait..."

Note

If the destination disk has not been formatted, the logic analyzer will automatically format the disk before it writes to it.

If the amount of data on the source disk exceeds the available memory in the logic analyzer, the logic analyzer will display “Insert the source disk-hit select when ready” again, and you will need to repeat the process of inserting the source disk, then the destination disk. Follow the directions on screen until the entire disk is duplicated

When the entire disk is duplicated, you will see “Hit FORMAT key to copy another disk or insert system disk and hit SELECT to reboot.” If you are **finished** duplicating disks, insert the system disk and press SELECT. The logic analyzer will load the system **file** and return you to the System Configuration menu.

Making Hardcopy Prints

Introduction

The HP 1652B/1653B Logic Analyzers **allow** you to print configurations, waveforms, and listings. Whenever your printer is connected to the logic **analyzer** and you instruct it to do so, it **will** print what is currently displayed on screen or **all** data in the menus having off-screen data.

This chapter shows you how to set up the logic analyzer's HP-IB and RS-232C interfaces for printers. If you have a Hewlett-Packard **ThinkJet**, **QuietJet**, or LaserJet series printer with the RS-232C interface, the RS-232C interface is already set up for you with the exception of the printer type and page width.

If you have another kind of printer, refer to your printer manual for its interface requirements and change the logic analyzer's interface configuration as instructed.

Supported Printers

The HP 1652B/1653B logic analyzers **will** support the following printers with HP-IB or RS-232C capabilities. For the following RS-232C printers, these configurations should be used:

- HP **ThinkJet** (RS-232C switches set for HP controllers)
- HP **QuietJet** (factory settings)
- HP LaserJet (factory settings)
- Alternate

Alternate Printers

In addition to HP printers, the **logic** analyzers **support** Epson@ compatible RS-232C printers. These alternate printers must support graphics.

When the logic analyzer's RS-232C configuration is **set** for alternate printers, it transmits data to the printer in the Epson **®** format.

Printers incompatible with either HP or Epson data transfer formats will not work with the HP **1652B/1653B** logic analyzers.

Hooking Up Your Printer

If your printer is already connected to the logic analyzer, skip to “Setting the RS-232C for HP Printers” or “Setting the **HP-IB** for HP Printers” in this chapter. Otherwise hooking up your HP printer is just a matter of having the correct HP-IB or RS-232C interface cable. Refer to the figure below.

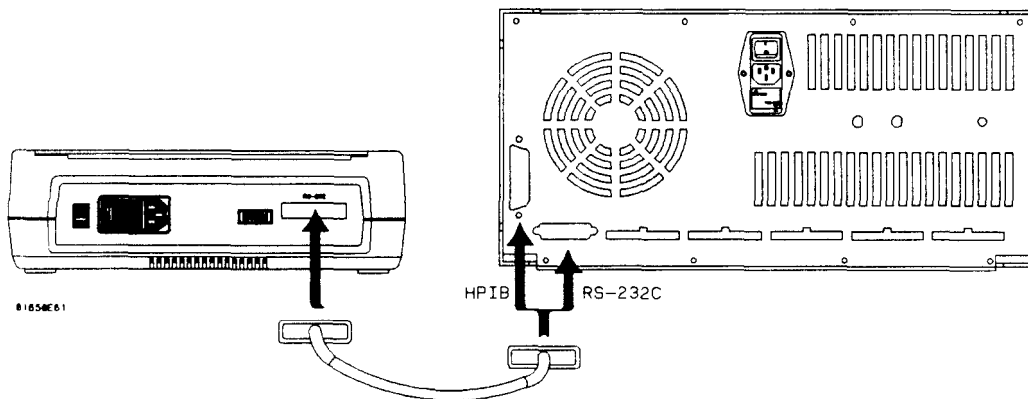

Figure 7-1. Logic Analyzer to Printer Hook-up

The type of connector on the printer end of the interface cable is determined by the kind of printer.

HP-IB Printer Cables

You can use any standard HP-IB cable to connect the logic analyzer to the printer. The specific HP-IB cable only depends on the length you need.

RS-232C Printer Cables

You can use either an HP 13242G or HP 92219H cable to connect the logic analyzer to the printer. However, the HP 132426 is the preferred cable since it can be used with either no protocol (hardware handshake) or XON/XOFF.

HP 13242G Cable

The HP 13242G cable has standard DB-25 connectors on each end and is wired for hardware handshake. The cable schematic is shown below.

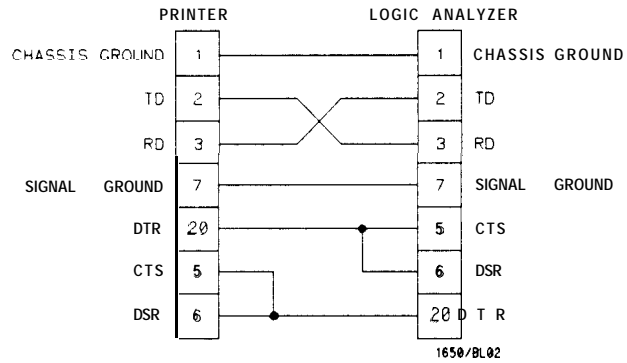

Figure 7-2. HP 132426 Cable Schematic

Note 3

HP 13242G cable ends are the same, therefore it doesn't matter which end of the cable is connected to which piece of equipment.

HP 92219H Cable

The HP 92219H cable has standard DB-25 connectors on each end and is wired for **XON/XOFF** handshake. The cable schematic is shown below.

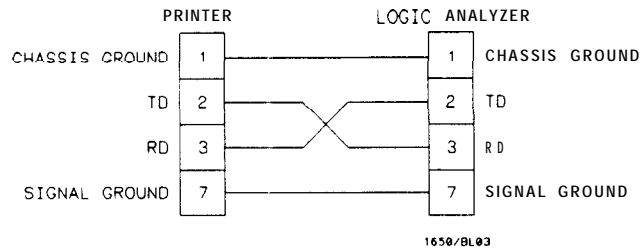

Figure 7-3. HP 92219H Cable Schematic

Setting HP-IB for HP Printers

The HP 1652B/53B interfaces directly with HP PCL printers supporting the printer command language. These printers must also support HP-IB and "Listen Always." Printers currently available from Hewlett-Packard with these features include:

- HP 2225A ThinkJet
- HP 2227B QuietJet
- HP 3630A option 002 PaintJet

Note

The printer must be in "Listen Always" when HP-IB is the printer interface. The HP 1652B/53B HP-IB port does not respond to service requests (SRQ) when controlling a printer. The SRQ enable setting for the HP-IB printer has no effect on the HP 1652B/53B operation.

For HP-IB printers, the Printer connected to field must be set to HP-IB in the I/O Port Configuration menu. You access the I/O Port Configuration menu by first accessing the I/O menu, then the I/O Port Configuration.

Setting RS-232C for HP Printers

All three series of HP printers (HP **ThinkJet**, HP LaserJet, and HP **QuietJet**) use the logic analyzer's RS-232C default configuration with only one or two changes depending on which printer you have.

Since the logic analyzer's default RS-232C configuration is set for the HP **ThinkJet** printer, no changes are needed for the HP **ThinkJet**.

For **RS-232C** printers, the Printer connected to field must be set to RS-232C in the I/O Port Configuration menu. You access the I/O Port Configuration menu by first accessing the I/O menu, then the I/O Port Configuration menu.

Listed below, are the changes you need to make for other HP printers:

- . Printer type for the HP LaserJet and HP **QuietJet**.
- . Paper width for the HP **QuietJet**.

You access the printer type and page width fields by first accessing the I/O menu, then the I/O Port Configuration menu.

Setting RS-232C for Your Non-HP Printer

The following attributes of the RS-232C interface must be set to the correct configuration for your printer:

- Protocol.
 - . Number of data bits.
 - Number of stop bits.
- Parity type.
- Baud rate.
- . Paper width.

You access these fields by first accessing the I/O menu then the I/O Port Configuration menu.

Setting Paper Width

Paper width is set by toggling the **Paper width** : _____ field in the **I/O Port Configuration** menu. It tells the printer that you are sending up to **80** or **132** characters per line (only when you Print **All**) and is **totally** independent of the printer itself.

- If you select **132** characters per line (**13.5** inches) when using other than an HP **QuietJet** selection, the listings are printed in a compressed mode. Compressed mode uses smaller characters to allow the printer to print more characters in a given width.
- If you select **132** characters per line (**13.5** inches) on an HP **QuietJet**, it will print a full 132 characters per line.
- If you select 80 characters per line for any printer, a maximum of 80 characters are printed per line.

RS-232C Default Configuration

You can use the logic analyzer's default configuration (except for printer type and paper width) for all supported printers if you haven't changed the printer's RS-232C configuration.

The logic analyzer's default configuration is:

Protocol: **XON/XOFF**
Data Bits: 8
Stop Bits: 1
Parity: none
Baud rate: 9600
Printer: **ThinkJet**
Paper width: 8.5 inches

Recommended Protocol

The recommended protocol is **XON/XOFF**. This allows you to use the simpler three-wire hook-ups.

Starting the Printout

When you are ready to print, you need to know whether there is more data than is displayed on screen. In cases where data is off screen (i.e., format specifications with all pods assigned to a single analyzer), you need to decide whether you want just the data that is on screen or all the data.

If you want just what is on screen, start the printout with the Print Screen option. If you want all the data, use the Print All option. Both options are in the **I/O** menu. Once you decide which option to use, start the printout by placing the cursor on the print option (screen or all) and pressing **SELECT**.

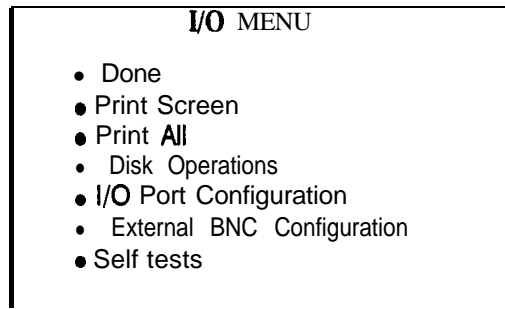

Figure. 7 - 4. I/O Menu

Print Screen

The Print Screen option prints only what is displayed on screen at the time you initiate the printout. In the Print Screen mode, the printer uses its graphics capabilities and the printout will look just like the logic analyzer screen with only one exception: the cursor will not print.

Print All

The Print All option prints not only what is displayed on screen, but also what is below, and, in the Format Specification, what is to the right of the screen at the time you initiate the printout.

Note

Make sure the first line you wish to print is at the top of the screen when you select Print All. **Lines** above the screen will not print.

Use this option when you want to print all the data in the following menus:

- Timing Format Specifications.
- State Format Specifications.
- State Trace Specifications.
- State Listing.
- Symbols..
- Disk Directory.

What Happens During a Printout?

When you press SELECT to start the printout, the I/O menu pop-up disappears and an advisory "PRINT in progress" appears in the top center of the display. While the data is transferred to the printer, the only **useable** key is the STOP key. When the logic analyzer has completed the data transfer to the printer, the advisory "PRINT complete" appears and the keyboard becomes **useable** again.

The PRINT in progress advisory won't appear in your printout. If you press STOP while the data is being transferred to the printer the transfer stops and the data already sent will print out. This causes an incomplete printout.

Connecting to Other HP Printers

The HP 1652B/53B can also be used with Hewlett-Packard printers that have RS-232C interface options. Simply connect the printer with the HP 13242G cable. Refer to table 7-1 for the appropriate selection for the RS-232C **configuration** of the HP 1652B/53B.

Table 7-1. HP Printer Selection

For this HP Printer	Select this Printer in I/O Port Configuration menu
HP 2631	QuietJet
HP 2671	ThinkJet
HP 2673	ThinkJet

The above printers should work with the HP 1652B/53B logic analyzers. However, no tests have been made to **verify** that they will work completely. Therefore, proper operation is neither promised nor supported by Hewlett-Packard.

The State Analyzer

Introduction

This chapter introduces the state analyzer and contains the state analyzer menu maps.

- Chapter 9 explains the State Format menu
- Chapter 10 explains the State Trace menu
- Chapter 11 explains the State **Listing** menu
- Chapter 12 explains the State Compare menu
- Chapter 13 explains the State Chart menu
- Chapter 14 explains the State Waveform menu
- Chapter 15 gives you a basic State Analyzer Measurement example

The State Analyzer (An Overview)

The state analyzer acquires data synchronously using the system-under-test to clock the acquired data. The acquired data is displayed in a list form in the State Listing menu and in waveform form in the State Waveform menu. The state analyzer differs from the timing *analyzer* in that the acquisition clock is provided by the system-under-test instead of the internal acquisition clock used by the timing analyzer. Therefore, the State Waveform menu displays the state waveforms referenced by states per division and not seconds per division as in the timing analyzer.

State Analyzer Menu Maps

The State Analyzer menu maps show you the fields and the available options of each field within the six menus. The menu maps will help you get an overview of each menu as well as provide you with a quick reference of what each menu contains.

State Format Menu Map

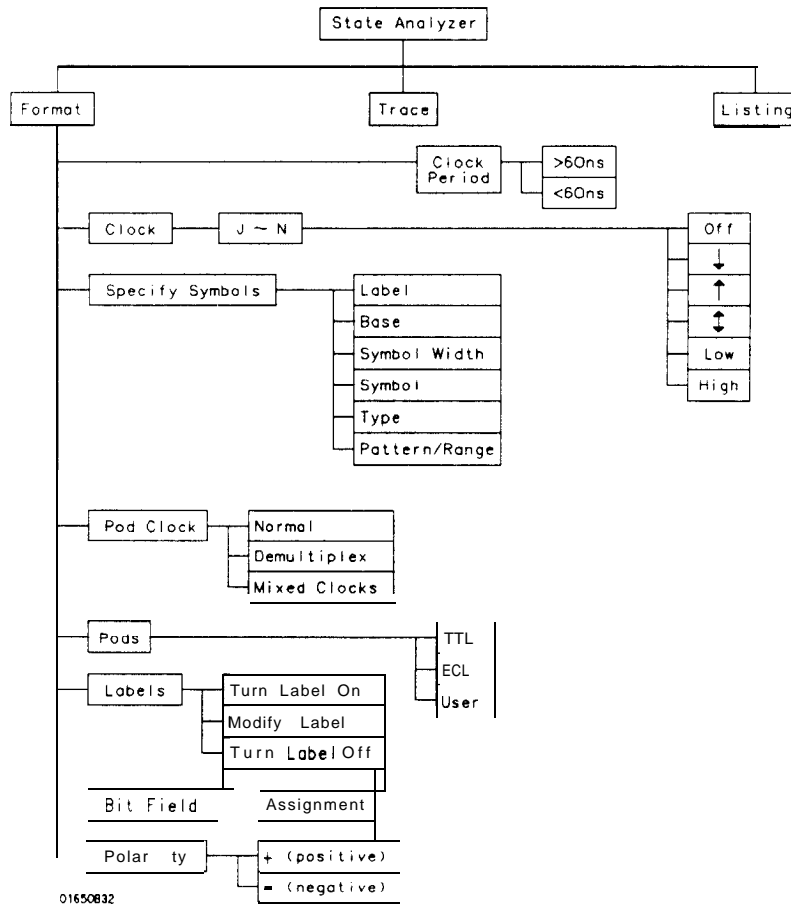

Figure 8-1. State Format Menu Map

State Trace Menu Map

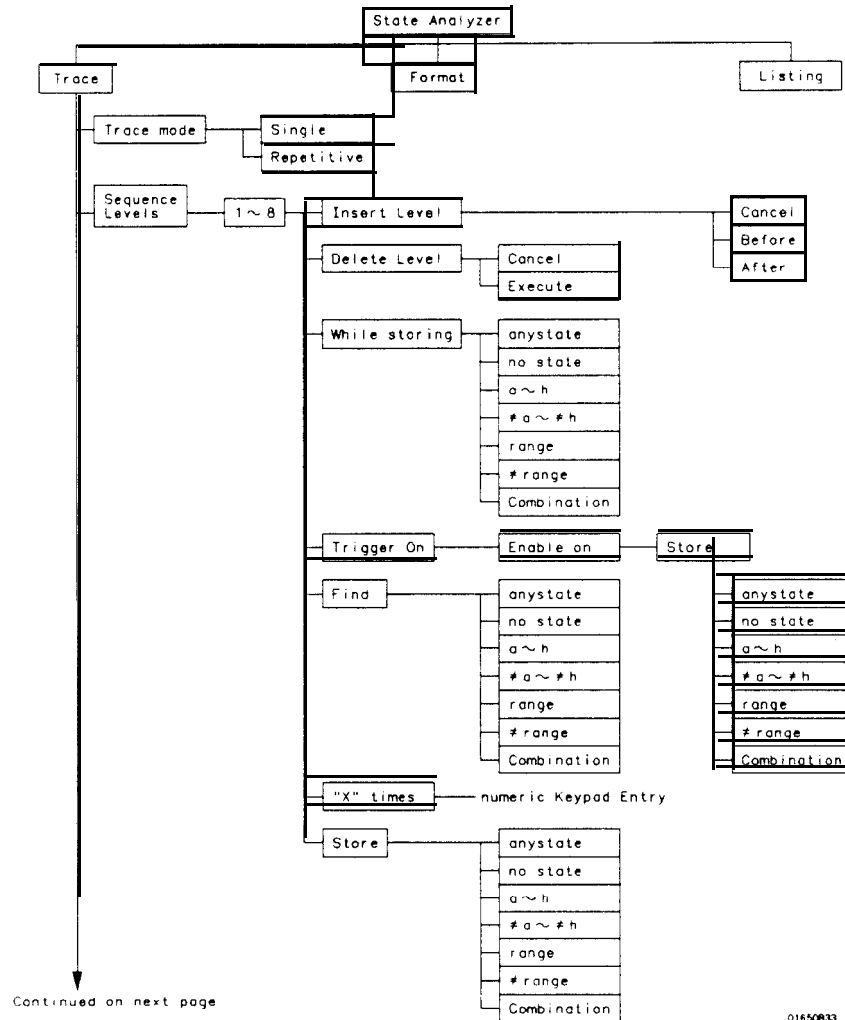
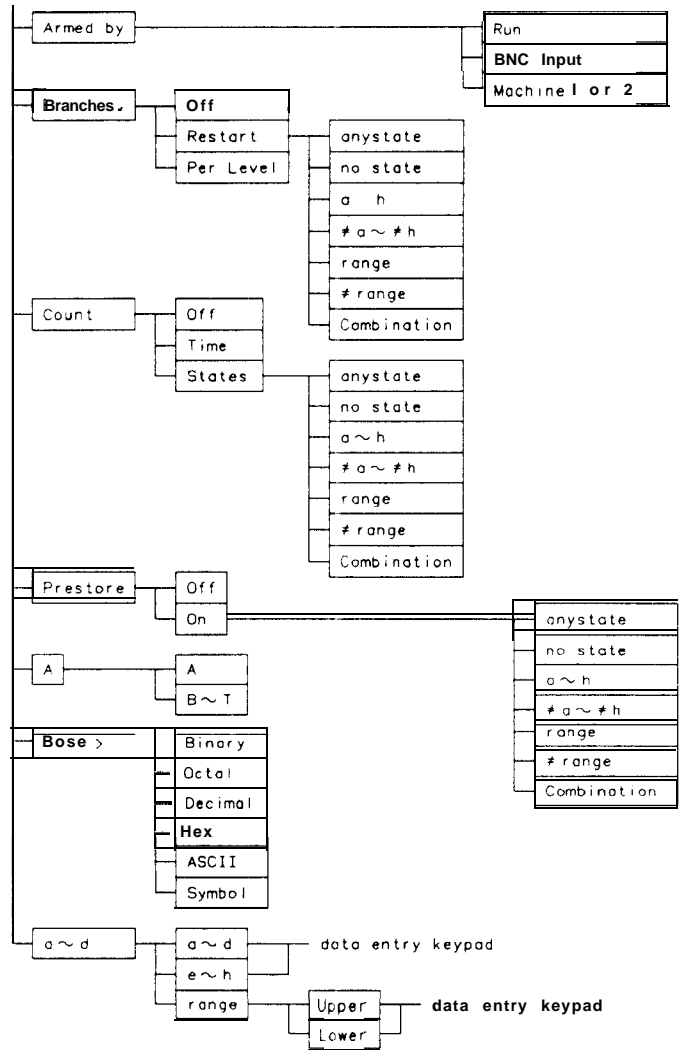

Figure 6-2. State Trace Menu Map

Continued from previous page



01650834

Figure 8-2. State Trace Menu Map (continued)

State Listing Menu Map

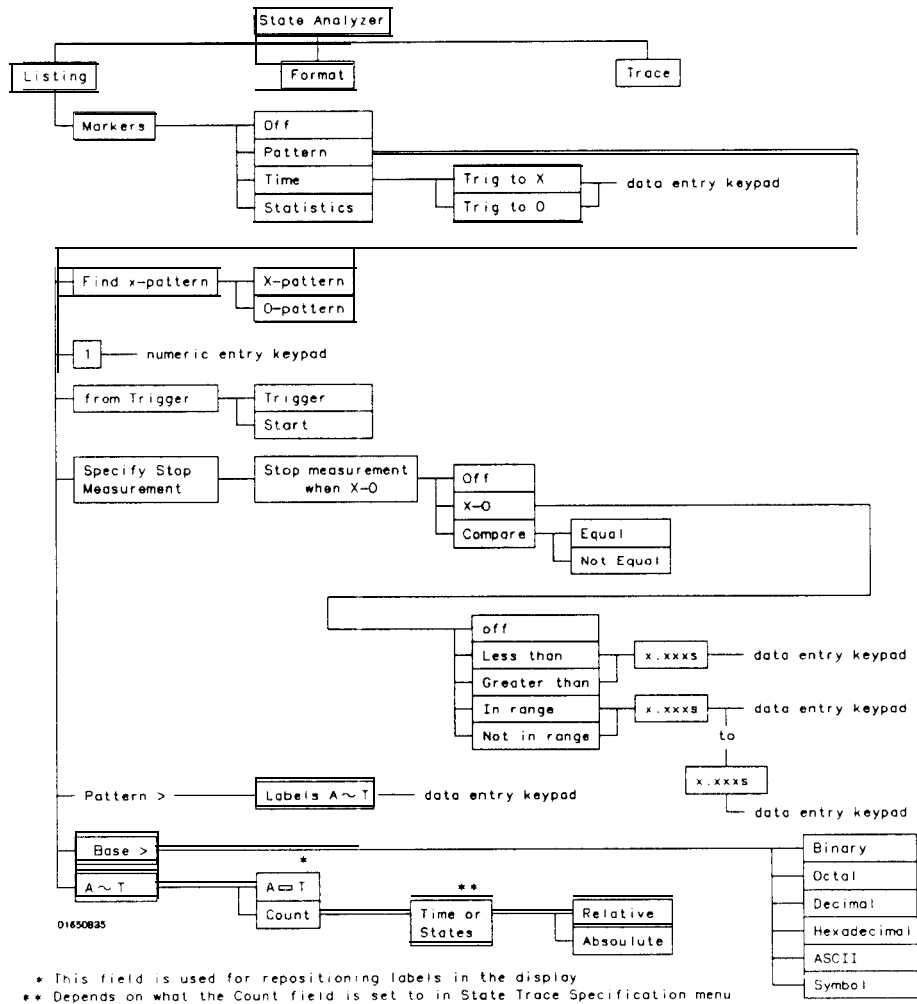

Figure 6-3. State Listing Menu Map

State Compare Menu Map

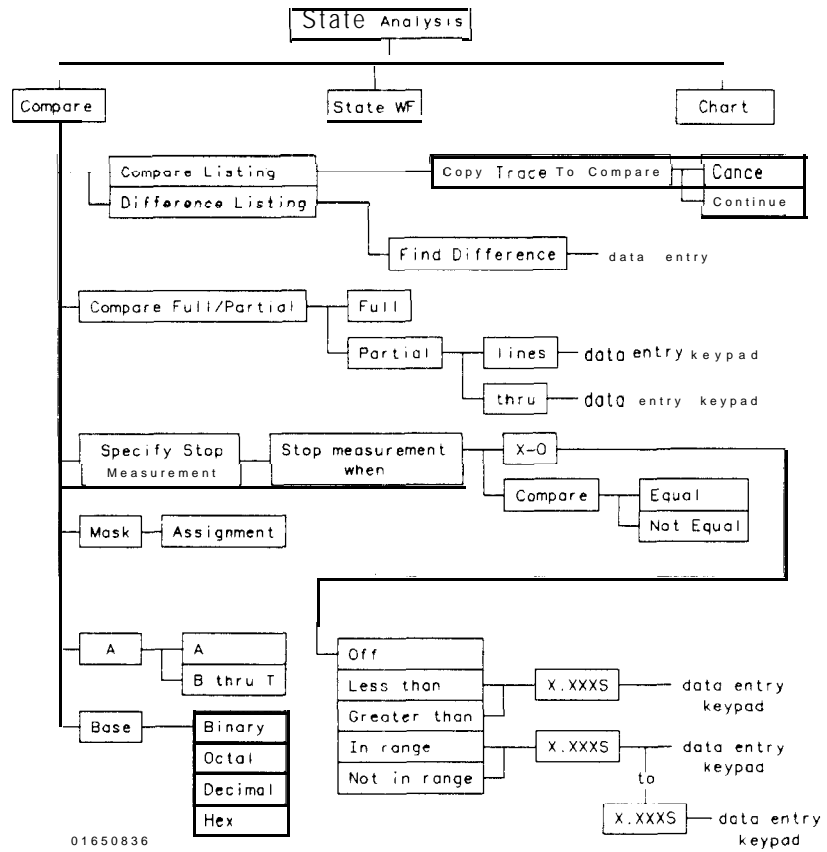

Figure 8-4. State Compare Menu Map

State Waveform Menu Map

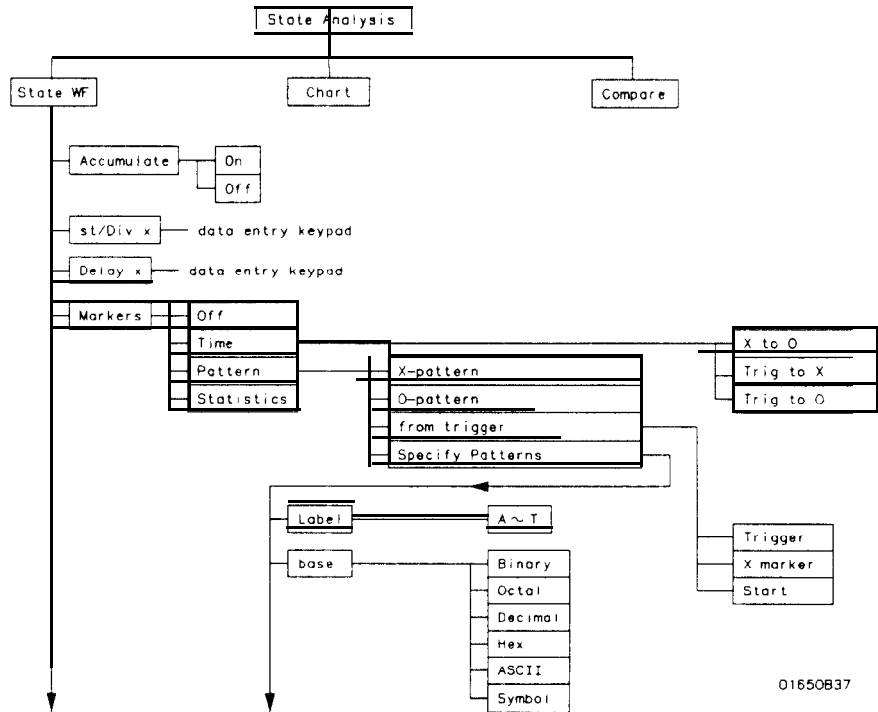

Figure 8-5. State Waveform Menu Map

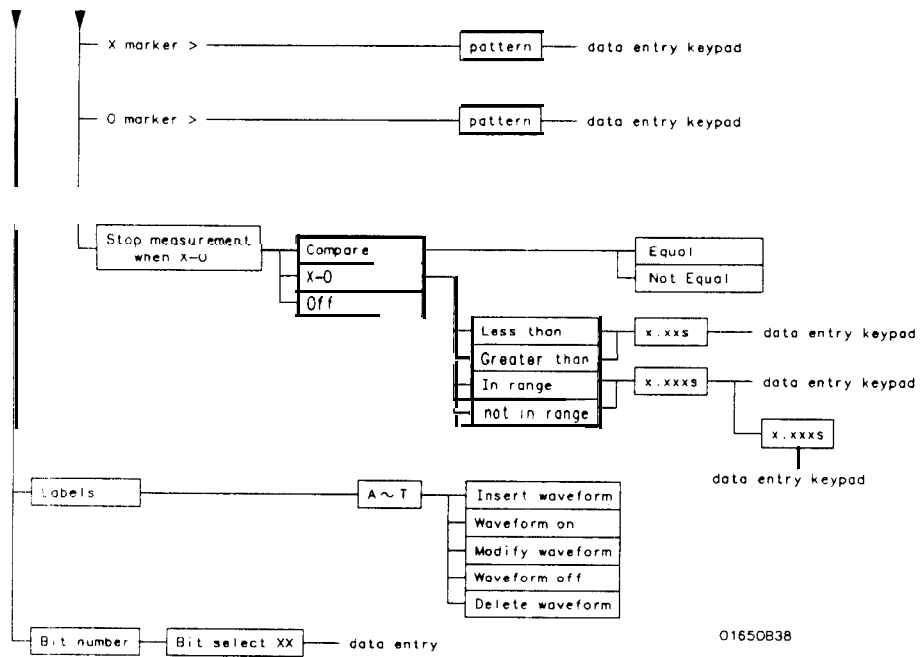

Figure 8-5. State Waveform Menu Map (continued)

State Chart Menu Map

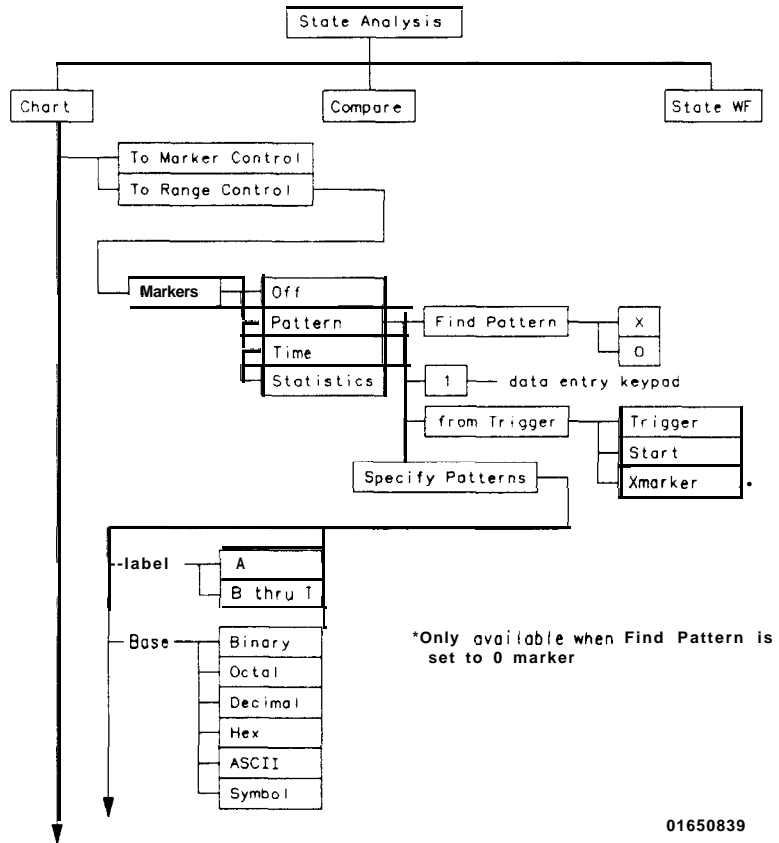

Figure 8-6. State Chart Menu Map

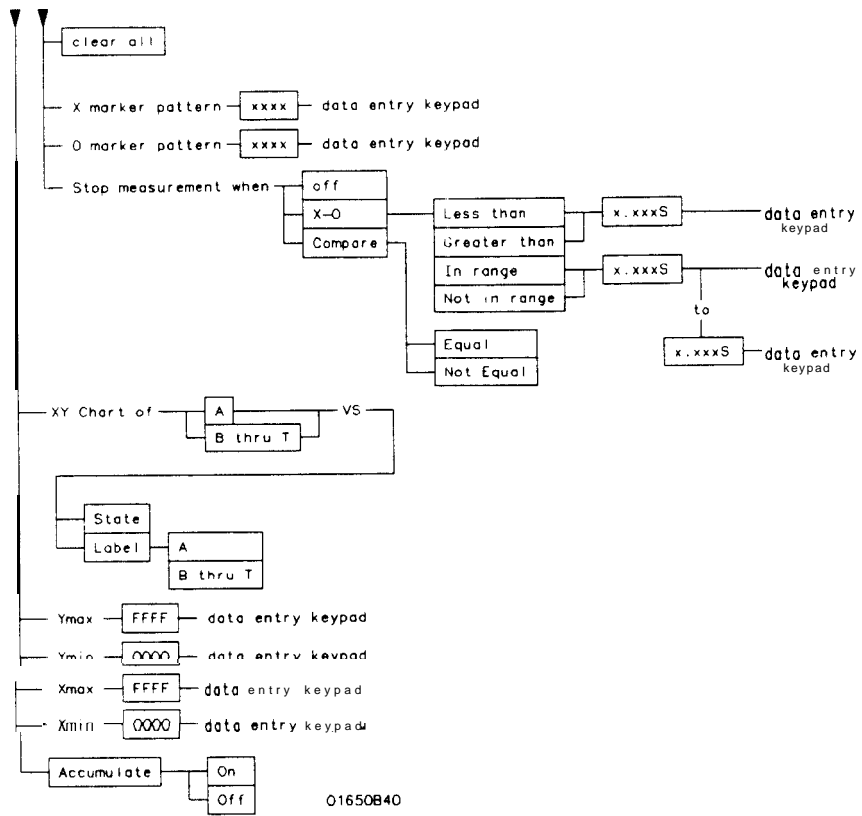

Figure 6-6. State Chart Menu Map (continued)

State Format Specification Menu

Introduction

This chapter describes the State Format Specification menu and all pop-up menus that you will use on your state analyzer. The purpose and functions of each menu are explained in detail, and we have included many illustrations and examples to make the explanations clearer.

Accessing the State Format Specification Menu

The State Format Specification menu can be accessed by pressing the FORMAT key on the front panel. If the Timing Format Specification Menu is displayed when you press the FORMAT key, you will have to switch analyzers. This is not a problem, it merely indicates that the last action you performed in the System Configuration Menu was on the timing analyzer.

State Format Specification Menu

The State Format Specification menu lets you **configure** the logic analyzer to group channels from your microprocessor into labels you assign for your measurements. You can set the threshold levels of the pods assigned to the state analyzer, assign labels and channels, specify symbols, and set clocks for triggering.

At power up, the logic analyzer is configured with a default setting. You can use this default setting to make a test measurement on the system under test. It can give you an idea of where to start your measurement. For an example of setting up configurations for the state analyzer, refer to your *Getting Started Guide* or “State Analyzer Measurement Example” in Chapter 15 of this manual.

At power up the State Format Specification menu looks like that shown below:

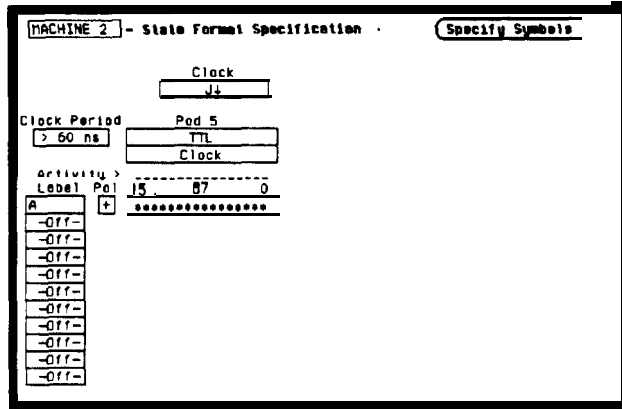

Figure S-1. State Format Specification Menu

The State Format Specification menu for the HP 1653B is similar to that for the HP 1652B except that Pod 2 appears in the menu instead of Pod 5.

This menu shows only one pod assigned to each analyzer, which is the case at power up. Any number of pods can be assigned to one analyzer, from none to all five for the HP **1652B**, and from none to two for the HP 1653B. In the State Format Specification **menu**, only three pods appear at a time in the display. To view any pods that are off screen, press the left/right ROLL key and rotate the KNOB. The pods are always positioned so that the lowest numbered pod is on the right and the highest numbered pod is on the left.

State Foimat Specification Menu Fields

Seven **types** of fields are present in the menus:

- Label
- Polarity (Pol)
- Bit assignments
- Pod threshold
- Specify Symbols
- Clock
- Pod Clock
- Clock Period

A portion of the menu that is not a field is the Activity Indicators display. The indicators appear under the active bits of each pod, next to "Activity >." When the logic analyzer is connected to your target system and the system is **running**, you will see ↓ in the Activity Indicators display for each channel that has activity. These tell you that the signals on the channels are **transitioning**.

The fields in the Format menus are described in the following sections.

Label The label column contains **20** Label fields that you can define. Of the **20** labels, the state analyzer displays only 11 labels at one time. To view the labels that are off screen, press the up/down ROLL key and rotate the KNOB. The labels scroll up and down. To deactivate the scrolling, press the ROLL key again.

To access one of the Label fields, place the cursor on the field and press SELECT. You will see a pop-up menu like that shown below.

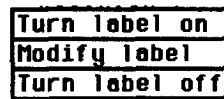

Figure 9-2. Label Pop-Up Menu

Turn Label On

Selecting this option turns the label on and gives it a default letter name. If you turned all the labels on they would be named A through T from top to bottom. When a label is turned on, bit assignment fields for the label appear to the right of the label under the pods.

Modify Label

If you want to change the name of a label, or want to turn a label on and give it a **specific** name, you would select the Modify label option. When you do, an Alpha Entry pop-up menu appears. You can use the pop-up menu and the keypad on the front panel to name the label. A label name can be a maximum of six characters.

Turn Label Off

Selecting this option turns the label off. When a label is turned off, the bit assignments are saved by the logic analyzer. This gives you the option of turning the label back on and **still** having the bit assignments if you need them. The waveforms and state listings are also saved.

You can give the same name to a label in the state analyzer as in the timing analyzer without causing an error. The logic analyzer distinguishes between them. An example of this appears in the *Getting Started Guide* and in chapter 15 of this manual

Polarity (Pol)

Each label has a polarity assigned to it. The default for all the labels is positive (+) polarity. You can change the polarity of a label by placing the cursor on the polarity field **and** pressing SELECT. **This** toggles the polarity between positive (+) and negative (-).

In the state analyzer, negative polarity inverts the data.

Bit Assignment

The bit assignment fields allow you to assign bits (channels) to labels. Above each column of bit assignment fields is a line that tells you the bit numbers from 0 to 15, with the left bit numbered 15 and the right bit numbered 0. This line helps you know exactly which bits you are assigning.

The convention for bit assignment is as follows:

- (asterisk) indicates assigned bit
- . (period) indicates unassigned bit

At power up the 16 bits of Pod 1 are assigned to the timing analyzer and the 16 bits of Pod 5 are assigned to the state analyzer.

To change a bit assignment configuration, place the cursor on a bit assignment **field** and press SELECT. You will see the following pop-up menu.

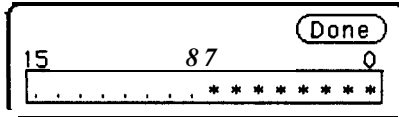

Figure 9-3. Bit Assignment Pop-Up Menu

Use the KNOB to move the cursor to an asterisk or a period and press SELECT. The bit assignment toggles to the opposite state of what it was before. When the bits (channels) are assigned as desired, place the cursor on Done and press SELECT. This closes the pop-up and displays the new bit assignment.

Assigning one channel per label may be handy in some applications. This is illustrated in chapter 8 of the *Getting Started Guide*. Also, you can assign a channel to more than one label, but this usually isn't desired.

Labels may have from 1 to 32 channels assigned to them. If you try to assign more than 32 channels to a label, the logic analyzer will beep, indicating an error, and a message will appear at the top of the screen telling you that 32 channels per label is the maximum.

Channels assigned to a label are numbered from right to left by the logic analyzer. The least significant assigned bit (LSB) on the far right is numbered 0, the next assigned bit is numbered 1, and so on. Since 32 channels can be assigned to one label at most, the highest number that can be given to a channel is 31.

Although labels can contain split fields, assigned channels are always numbered consecutively within a label. The numbering of channels is illustrated with the figure below.

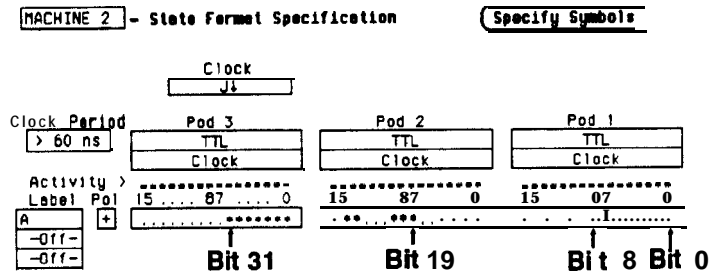

Figure 94. Numbering of Assigning Bits

Pod Threshold

Each pod has a threshold level assigned to it. For the HP 1653B Logic Analyzer, threshold levels may be defined for Pods 1 and 2 individually. For the HP 1652B Logic Analyzer, threshold levels may be defined for Pods 1, 2 and 3 individually, and one threshold for Pods 4 and 5. It does not matter if Pods 4 and 5 are assigned to different analyzers. Changing the threshold of one will change the threshold of the other.

If you place the cursor on one of the pod threshold fields and press SELECT, you will see the following pop-up menu.

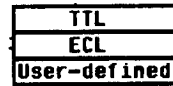

Figure 9-5. Pod Threshold Pop-Up Menu

TTL sets the threshold at + 1.6 volts, and ECL sets the threshold at - 1.3 volts.

The User-defined option lets you set the threshold to a specific voltage between -9.9 V and $+9.9$ V. If you select this option you will see a Numeric Entry pop-up menu as shown.

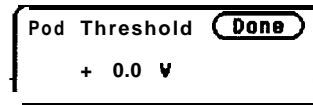

Figure 9-6. Userdefined Numeric Entry Pop-Up Menu

You can change the value in the pop-up either with the keypad on the front panel or with the KNOB, which you rotate until you get the desired voltage. When the correct voltage is displayed, press SELECT. The pop-up will close and your new threshold will be placed in the pod threshold field.

The threshold level you specify for the **16** data bits also applies to a pods clock threshold.

Specify Symbols

This field provides access to the Specify Symbols menu. It differs from the other fields in the State Format Specification menu in that it displays a complete menu instead of a pop-up. The complete description of the Specify Symbols Menu follows the State Format Specification Menu fields later in this chapter.

Clock

The Clock field in the Format Specification menu displays the clocks for clocking your system. The display will be referred to as the “clocking arrangement.”

The HP 1652B Logic Analyzer has five clock channels, each of which is on a pod. The clocks are connected **through** the pods simply for convenience. The clock **channels** are labeled J, K, L, M, and N and are on pods 1 through 5, respectively. The clocking of the state analyzer is synchronous with your system because your analyzer uses the signals present in your system. The signal you use must clock the analyzer when the data you want to acquire is valid.

The HP 1653B Logic Analyzer has two clock channels, each on one of the pods. The J clock is on pod 1 and the K clock is on pod 2.

When you select the Clock field, you will see the following pop-up menu with which you specify the clock.

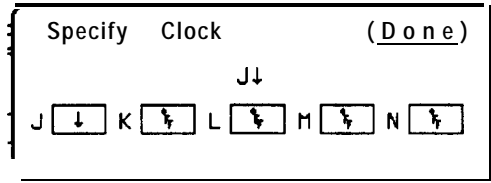

Figure 97. Clock Pop-Up Menu

You can use one of the clocks alone or combine them to build one clocking arrangement. If you select a field to the right of one of the clocks in the pop-up you will see another pop-up menu:

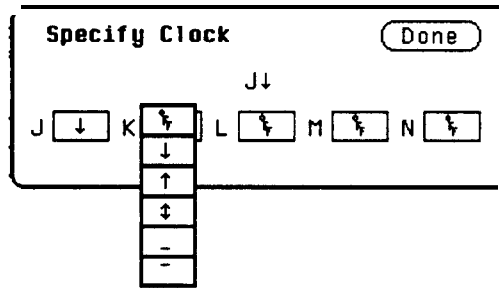

Figure 9-8. Single Clock Pop-Up Menu

You can specify the negative edge of the clock, the positive edge, either edge, a high level, a low level, or the clock to be off.

The clocks are combined by **ORing** and **ANDing** them. Clock edges are **ORed** to clock edges, clock levels are **ORed** to clock levels, and clock edges are **ANDed** to clock levels.

For example, if you select ↓ for the J clock, ↑ for the K clock, _ for the M clock, and - for the N clock, the resulting clocking arrangement will appear in the display as:

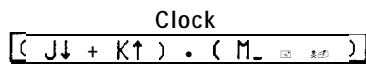

Figure 9-9. Example of a Clocking Arrangement

With this arrangement, the state analyzer will clock the data when there is a negative edge of the J clock OR a positive edge of the K clock, AND when there is a low level on the M clock OR a high level on the N clock.

You must always specify at least one clock edge. If you try to use only clock levels, the logic analyzer will display a message telling you that at least one edge is required.

Pod Clock Your logic analyzer has the capability of clocking data in three different ways. The pod **Clock** fields in the State Format Specification menu allow you to specify which of the three ways you want to clock the data.

Each pod assigned to the state analyzer has a pod Clock field associated with it. Selecting one of the pod Clock fields gives you the following pop-up menu:

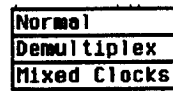

Figure 9-10. Pod clock Field Pop-Up Menu

Normal

This option specifies that clocking will be done in single phase. That is the clocking arrangement located in the Clock field above the pods in the State Format Specification menu will be used to clock all the pods assigned to this machine.

For example, suppose that the Clock field looks like the following:

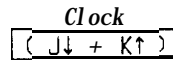

Figure 9-11. Example of a Clocking Arrangement

In Normal mode the state analyzer will sample the data on any assigned pods on a negative edge of the J clock OR on a positive edge of the K clock.

Demultiplex

With the HP 1652B/1653B Logic Analyzers, you can clock two different types of data that occur on the same lines. For instance, lines that transfer both address and data information need to be clocked at different times in order to get the right information at the right **time**.

When you select the Demultiplex option, the pod Clock field changes to “Master | Slave,” and two clock fields appear above the pods where **just** one Clock field used to be. These fields are the Master Clock and Slave Clock, as shown:

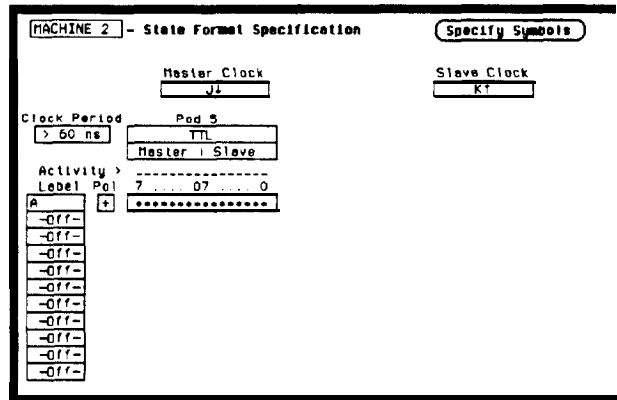

Figure 9-12. Master Clock and Slave Clock

Demultiplexing is done on the data lines of the specified pod to read only the lower eight bits. This is two-phase clocking, with the Master Clock following the Slave Clock. The analyzer first looks for the clocking arrangement that you specify in the Slave Clock. When it sees this arrangement, the analyzer clocks the data present on bits 0-7 of the pod, then waits for the clocking arrangement that you specify in the Master Clock. When it sees this arrangement, it again clocks the data present on bits 0-7 of the pod. The upper eight bits of the pods are ignored and don't need to be connected to your system.

Notice, the bit numbers that appear above the bit assignment field have changed. The bits are now numbered 7 07 0 instead of 15 87 0 . This helps you set up the analyzer to clock the right information at the right time.

The address/data lines ADO-AD7 on the 8085 microprocessor are an example of Demultiplex. During part of the operating time the lines have an address on them, and during other times they have data on them. Hook the lower eight bits of one of the pods to these eight lines **and** set the Slave and Master Clocks so that they clock the data and the address at the proper time.

In this example, you may choose to assign the bits in the State Format Specification menu similarly to that shown below. In this case you would want to clock the address with the Slave Clock and the data with the **Master Clock**.

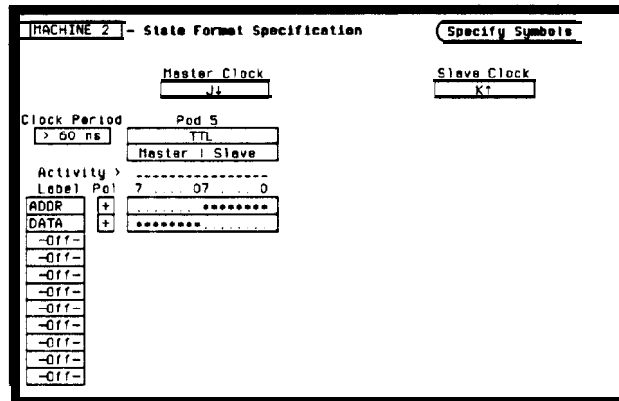

Figure s-13. Master and Slave Clock Bit Assignments

The Master and Slave Clocks can have the same clocking arrangements. The clocking is still done the same way, with the lower eight bits being clocked **first** on the Slave Clock, then on the Master Clock.

Mixed Clocks

The Mixed Clocks option allows you to clock the lower eight bits of a pod separately from the upper eight bits. The state analyzer uses Master and Slave Clocks to do this. If you select this option from the pod Clock pop-up, the pod Clock field changes to "Master Slave," and two Clock fields, Master and Slave, appear above the pods.

As in Demultiplex, the Master Clock follows the Slave Clock. The state analyzer looks for the clocking arrangement given by the Slave Clock and clocks the lower eight bits. Then it looks for the clock arrangement given by the Master Clock **and** clocks the upper eight bits. Unlike Demultiplex, all 16 bits of a pod are sampled.

The Master and Slave Clocks can have the same clocking arrangements. The clocking is still done the same way, with the lower eight bits clocked on the Slave Clock **and** the upper eight bits clocked on the Master Clock.

Clock Period

This field provides greater measurement accuracy when your state input clock period is greater than 60 **ns**. When you select **> 60 ns**, the state analyzer provides greater immunity against noise or ringing in the state input clock signal; also, the logic analyzer provides greater accuracy when triggering another state or timing analyzer or the BNC trigger out.

If your State input clock period is less than 60 ns, you should select **< 60 ns**. This disables the Count field in the State Trace Specification menu because the maximum clock rate when counting is 16.67 MHz (60 **ns** clock period). This also turns Prestore off.

Specify Symbols Menu

The logic analyzer supplies Timing and State Symbol Tables in which you can **define** a mnemonic for a specific bit pattern of a label. When measurements are made by the state **analyzer**, the mnemonic is displayed where the bit pattern occurs if the Symbol base is selected.

It is possible for you to specify up to 200 symbols in the logic analyzer. If you have **only** one of the internal **analyzers** on, all 200 symbols can be defined in it. If both analyzers are on, the 200 symbols are split between the two. For example, analyzer 1 may have **150**, leaving 50 available for analyzer 2.

To access the Symbol Table in the State Format Specification menu, place the cursor on the Specify Symbols **field** and press SELECT. You **will** see a new menu as shown. This is the default setting for the Symbol Table in both the timing and state analyzers.

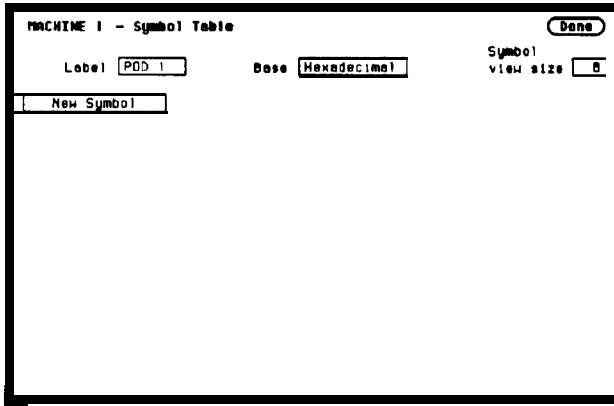

Figure 414. Symbol Table Menu

Specify Symbols Menu Fields

There are four fields in the Symbol Table menu. They are:

- Label
- Base
- Symbol view size
- Symbolname

Label The **Label** field identifies the label for which you are specifying symbols. If you select this field, you will get a pop-up that lists all the labels turned on for that analyzer.

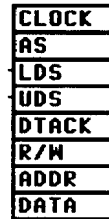

Figure 9-15. Lable Pop-Up Menu

Each label has a separate symbol table. This allows you to give the same name to symbols defined under different labels. In the Label pop-up select the label for which you wish to **specify** symbols.

Base The Base field tells you the numeric base in which the pattern will be specified. The base you choose here will affect the pattern field of the State Trace Specification menu. This is covered later in this chapter.

To change the base, place the cursor on the field and press SELECT. You will see the following pop-up menu.

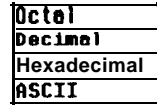

Figure 9-16. Base **Pop-Up Menu**

If more than **20** channels are assigned to a label, the Binary option is not offered in the pop-up. The reason for this is that when a symbol is specified as a range, there is only enough room for 20 bits to be displayed on the screen.

Decide which base you want to work in and choose that option from the numeric Base pop-up menu.

If you choose the ASCII option, you can see what ASCII characters the patterns and ranges defined by your symbols represent. ASCII characters represented by the decimal numbers 0 to **127** (hex 00 to 7F) are offered on your logic analyzer. Specifying patterns and ranges for symbols is discussed in the next section.



You cannot specify a pattern or range when the base is ASCII. First **define** the pattern or range in one of the other bases, then switch to ASCII to see the ASCII characters.

Symbol View Size The **Symbol** view **size** field lets you specify how many characters of the symbol name will be displayed when the symbol is referenced in the State Trace Specification menu and the State Listing menu. Selecting this field gives you the following pop-up.

3
4
5
6
7
8
9
10
11
12
13
14
15
16

Figure 9-17. Symbol View Size Pop-Up Menu

You can have the logic analyzer display from 3 to all 16 of the characters in the symbol name. For more information see “State Trace Specification Menu” and “State Listing Menu” later in this chapter.

Symbol Name When you first access the Symbol Table, there are no symbols specified. The symbol name field reads “New Symbol.” If you select this field, you will see an Alpha Entry pop-up menu on the display. Use the pop-up menu and the keypad on the front panel to enter the name of your symbol. A maximum of 16 characters can be used in a symbol name.

When you select the Done field in the Alpha Entry pop-up menu the name that appears in the symbol name field is assigned and two more fields appear in the display.

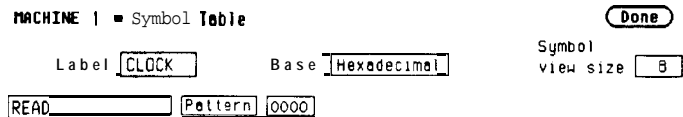

Figure 9-18. Symbol Defined as a Pattern

The **first** of these fields defines the symbol as either a Pattern or a Range. If you place the cursor on this **field** and press SELECT, it **will** toggle between Pattern and Range.

When the symbol is defined as a pattern, one field appears to specify what the pattern is. Selecting this field gives you a pop-up with which you can specify the pattern. Use the keypad and **the** DON'T CARE key on the front panel to enter the pattern. Be sure to enter the pattern in the numeric base that you specified in the Base field.



Figure Q-19. Specify Pattern Pop-Up Menu

If the symbol is defined as a range, **two** fields appear in which you specify the upper and lower boundaries of the range.

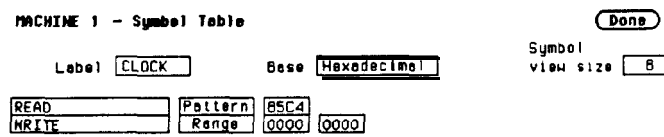

Figure Q-20. Symbol Defined as a Range

Selecting either of these fields gives you a pop-up with which you can specify the boundary of the range.

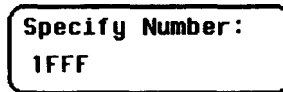

Figure Q-21. Specify Range Pop-Up Menu

You can specify ranges that overlap or are nested within each other. Don't cares are not allowed.

To add more symbols to your symbol table, place the cursor on the last symbol defined and press SELECT. A pop-up menu appears as shown.

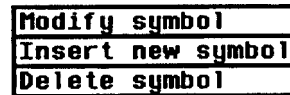

Figure Q-22. Symbol Pop-Up Menu

The **first** option in the pop-up is Modify symbol. If you select this option, you will see an Alpha Entry pop-up menu with which you can change the name of the symbol.

The second option in the pop-up is Insert new symbol. It allows you to specify another symbol. When you select it, you will see an Alpha Entry pop-up menu. Use the menu and the keypad on the front panel to enter the name of your new symbol. When you select Done, your new symbol will appear in the Symbol Table. The third option in the pop-up is Delete symbol. If you select this option, the symbol will be deleted from the Symbol Table.

Leaving the Symbol Table Menu

When you have specified all your symbols, you can leave the Symbol Table menu in one of two ways. One method is to place the cursor on the Done **field** and press SELECT. This puts you back in the Format Specification menu that you were in before entering the Symbol Table. The other method is to press the FORMAT, TRACE, or DISPLAY keys on the front panel to get you into the respective menu.

State Trace Menu

Introduction

This chapter describes the State Trace menu and the pop-up menus that you will use on your state analyzer. The purpose and functions are described in detail, and we have included many illustrations and examples to make the explanations clearer.

The Trace **Specification** menu allows you to configure the state analyzer to capture only the data of interest for your measurement. In the state analyzer you can **configure** the analyzer to trigger on a sequence of states. The default setting is shown in **figure 10-1** below.

For an example of setting up a trace configuration for a State analyzer, refer to your *Getting Started Guide* or “State Analyzer Measurement Example” in Chapter 15 of this manual.

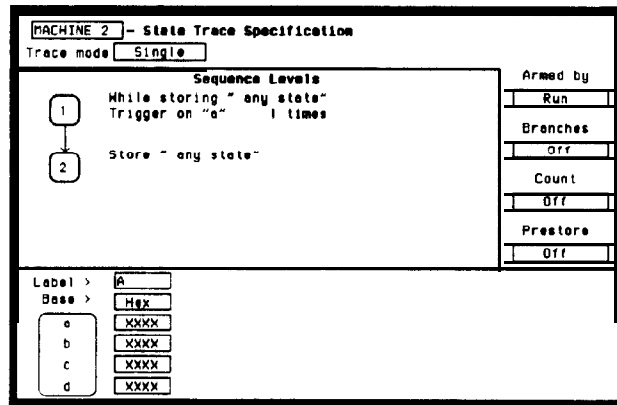

Figure 10-1. State Trace Specification Menu

Accessing the State Trace Menu

The State Trace menu can be accessed by pressing the TRACE key on the front panel. If the Timing Trace Specification menu is displayed when you press the TRACE key, you will have to switch analyzers. This is not a problem, it merely indicates that the last action you performed in the System Configuration Menus was on the timing analyzer.

State Trace Menu Fields

The menu is divided into three sections: the Sequence Levels in the large center box, the acquisition fields at the top and right of the screen, and the qualifier and pattern fields at the bottom of the screen.

Before describing the fields in the menu, we need to **define** a few terms. These terms will be used in the discussions of the fields, so understanding their meanings is essential.

Pattern Recognizers: a pattern of bits (0, 1, or X) in each label. There are eight recognizers available when one state analyzer is on. Four are available to each analyzer when two state analyzers are on. The pattern recognizers are given the names a through h and are partitioned into groups of four, a-d and e-h.

Range Recognizer: recognizes data which is numerically between or on two specified patterns. One range term is available and is assigned to the first state analyzer created by assigning pods to it or if only one analyzer is on, then the range term is assigned to it.

Qualifier: **user-specified** term that can be **anystate**, **nostate**, a single pattern recognizer, a range **recognizer**, the complement of a pattern or range recognizer, or a logical combination of pattern and range recognizers. To specify a **qualifier**, you will use the pop-up shown in figure 10-2. This pop-up appears when accessed through the five different fields encountered when setting qualifiers throughout the State Trace menu.

any state
no state
a
b
c
d
e
f
g
h
#a
#b
#c
#d
#e
#f
#g
#h
range
#range
Combination

Figure 10-2. Qualifier Pop-Up Menu

If you select the **Combination** option in the pop-up, you will see a pop-up similar to that shown below.

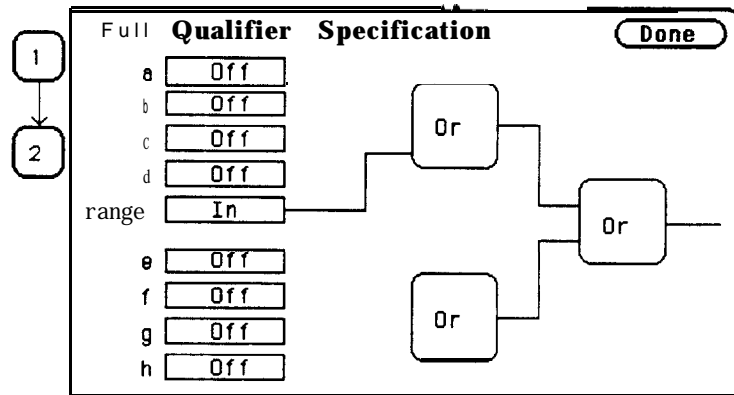

Figure 10-3. Full Qualifier Specification Pop-Up

Note 

If two multi-pod state analyzers are on, the qualifier pop-up menu will show that only four pattern recognizers are available **to each analyzer**. Pattern recognizers a-d and the range **recognizer** are assigned to the first analyzer created, and pattern recognizers **e-h go with the second** analyzer. In the Full Qualifier **Specification** pop-up there will be only one OR gate and one set of pattern recognizers.

With this Full **Qualifier** Specification pop-up, you specify a logical combination of patterns or ranges as the qualifier. The pattern **recognizers** are always partitioned into the groups of four shown. Only one operator is allowed between the patterns in a group. Patterns in uncomplimented form (a, b, etc.) can only be **ORed**.

The complements of patterns (\neq a, \neq b, etc.) can only be **ANDed**. For example, if the first OR **field** (gate) is changed to AND, all the patterns for that gate are complemented, as shown below.

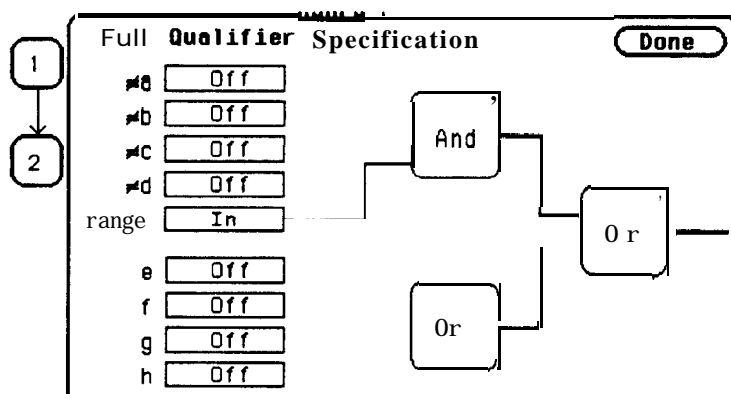

Figure 10-4. Complemented Patterns

To specify a pattern to be used in the combination, place the cursor on the pattern **recognizer** field and press SELECT. The field toggles from Off to On and a connection is drawn from the pattern field to the gate. In figure 10-5, patterns **b, c** and d and the range are **ORed** together, and e and g are **ANDed** together.

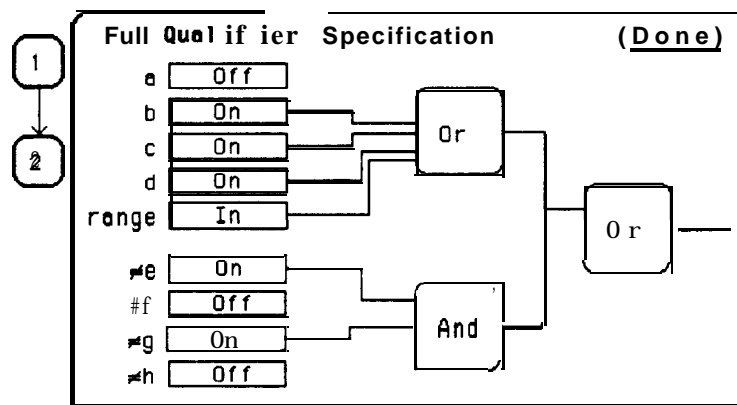

Figure 10-5. Patterns Assigned for Logical Combinations

As shown in the previous figures, the range is included with the first group of patterns (a-d). If you select the range field, you will see the following pop-up menu.

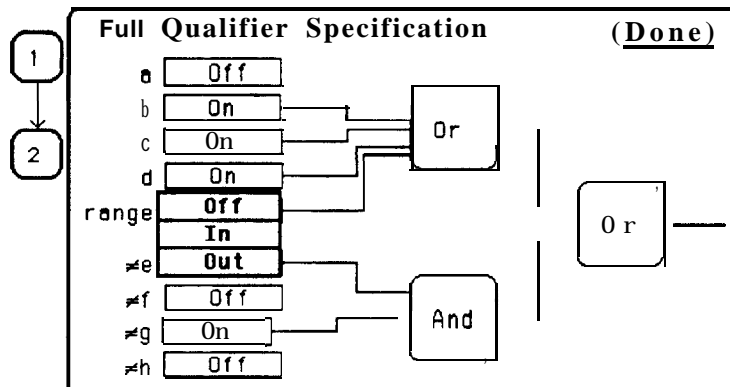

Figure 10-6. Range Specification Pop-Up Menu

Off disconnects the range **from** the qualifier specification. In indicates that the contents of the range are to be in the qualifier specification, and **Out** indicates that the complement of the range is to be in the qualifier specification.

When you have specified your combination qualifier, select Done. The Full Qualifier Specification pop-up closes and the Boolean expression for your qualifier appears in the field for which you specified it.

While storing

Figure 10-7. Boolean Expression for Qualifier

Sequence Levels

There are eight **trigger** sequence levels available in the state analyzer. You can add and delete levels so that you have from two to eight levels at a time.

Only three levels appear in the Sequence Levels display at one time. To display other levels so that they can be accessed, press the up/down ROLL key and rotate the KNOB.

If you select level 1 shown in figure 10-1, you will see the following pop-up menu:

The image shows a pop-up menu titled "Sequence Level 1" with a "(Done)" button in the top right corner. Below the title are two buttons: "Insert Level" on the left and "Delete Level" on the right. The main area of the menu contains the text "While storing any state" followed by a text input field. Below this, there is a label "Trigger on" followed by a text input field and a numeric input field containing the number "1", with the word "times" to the right of the numeric field.

Figure 10-8. Sequence Level Pop-Up Menu

Not all sequence level pop-up menus look like this one. This happens to be the trigger sequence level in which you specify the state on which the analyzer is to trigger. The trigger term can occur in any of the first seven levels, and it is not necessarily a selectable field. The fields in the menu of figure 10-8 are described on the following pages.

Insert Level To insert a level, place the cursor on the field labeled Insert Level and press SELECT. You will see the following pop-up menu.



Figure 10-9. Insert Level Pop-Up Menu

Cancel returns you to the sequence level pop-up without inserting a level. **Before** inserts a level before the present level. **After** inserts a level after the present level. If there are eight levels, the Insert Level field doesn't appear in the sequence level pop-ups.

Delete Level If you want to delete the present level, select the field labeled **Delete Level**. You will see a pop-up menu with the choices Cancel and Execute. Cancel returns you to the sequence level pop-up without deleting the level. **Execute** deletes the present level and returns you to the State Trace Specification menu.

Note 

If there are only two levels, neither field can be deleted even though the **Delete Level** field still appears in the menu. There will always be a trigger term level and a store term level in Sequence Levels. Therefore, if you try to delete either of these, all terms you have specified in these levels will be set to default terms, and, the trigger and store term levels will remain.

Storage Qualifier

Each sequence level has a storage qualifier. The storage qualifier specifies the states that are to be stored and displayed in the State Listing. Selecting this field gives you the qualifier pop-up menu shown in figure 10-2, with which you specify the qualifier.

As an example, suppose you specify the storage qualifier in a sequence level as shown below.

While storing

Figure 10-10. Storage Qualifier Example

The only states that will be stored and displayed are the states given by pattern **recognizers** a and d.

Branching Qualifier

Every sequence level except the last has a primary branching qualifier. With the branching qualifier, you tell the analyzer to look for a specific state or states. The primary branching qualifier advances the sequencer to the next level if its qualifier is satisfied.

In the example of figure 10-8, the branching qualifier tells the analyzer when to trigger. In other sequence levels, the qualifier may simply specify a state that the analyzer is to look for before continuing to the **next level**.

Some sequence levels also have a secondary branching qualifier. The secondary branch will, if satisfied, route the sequencer to a level that you define. This is covered in more detail in “Branches” later in this chapter.

Occurrence Counter

The primary branching qualifier has an occurrence counter. With the occurrence counter field you **specify** the number of times the branching qualifier is to occur before moving to the next level.

To change the value of the occurrence counter, position the cursor on the field and either press **SELECT** or press a numeric key on the front-panel keypad. You will see a pop-up similar to that shown below.

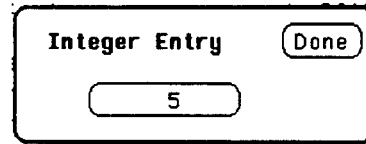

Figure 10-1 1. Occurrence Counter Pop-Up Menu

You can change the value by either rotating the KNOB or pressing the appropriate numeric keys. The qualifier can be specified to occur from one to 65535 times.

Storage Macro

Your logic analyzer has the **capability** of post-trigger storage through a storage macro. The storage macro is available only in the second to last level, and it consumes both that level and the last level. The field in figure 10-8 allows you to configure the state analyzer for post-trigger storage. This field does not always say Trigger on. If the sequence level is not a trigger level, the field will say Then find, as shown below.

Then find any state 1 times

Figure 10-12. Then Find Branching Qualifier

Selecting the field gives you a pop-up with two options. One option is what the field said previously. The other option is Enable on. If you select this option, the Sequence Level pop-up changes to look similar to that shown below.

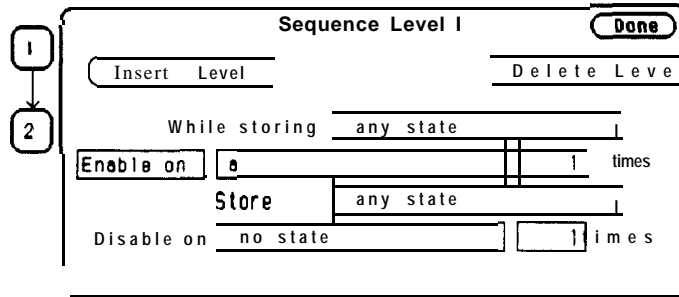



Figure 10-13. Storage Macro Sequence Level Example

Note 

Enable on can only be the next to last term, and when on, the last term is combined with the Enable term.

You specify **qualifiers** for the states on which you want the macro to enable, the states you want to store, and the states on which you want the macro to disable. The storage macro is a loop that keeps repeating itself until memory is full. The loop is repeated when the disable qualifier is satisfied. As an example, suppose you configure the sequence level of **figure 10-13** to look like that shown below.

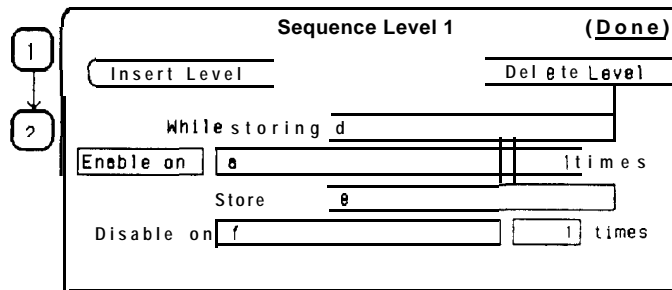

Figure 10-14. Sequence Level Pop-up with Storage Macro

The logic analyzer will store the state given by pattern recognizer **d** until it comes across the state given by a. When it sees state a, the logic analyzer starts to store the state given by pattern recognizer **e**. It stores that state until it sees the state given by **f**, at which time it disables and starts the process all over again. The analyzer repeats this process until its memory is full.

Reading the Sequence Level Display

Reading the display is fairly straightforward. For example, suppose your display looks like that shown below.

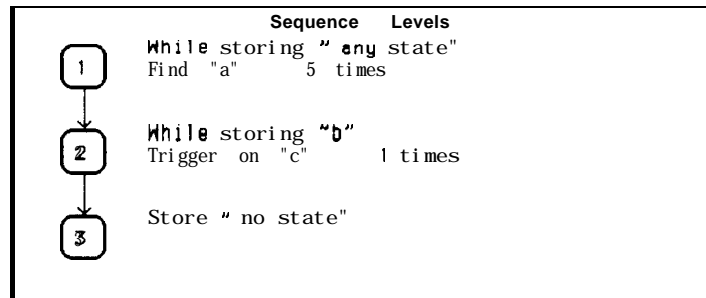

Figure 10-15. Sequence Level Display Example

In level 1 **anystate** is stored while the logic analyzer searches for live occurrences of the pattern given by pattern recognizer a. When the live occurrences are found, the sequencer moves on to level 2. In level 2 the state given by pattern recognizer b is stored until one occurrence of the pattern given by pattern recognizer c is found and the logic analyzer triggers. In level 3 **nostate** is stored, so the last state stored is the trigger state.

An example of a state listing for the previous State Trace configuration is **shown** below. The state patterns **specified** are:

a = **B03C**
b=0000
c = **8930**

```
MACHINE 2 - STATE LISTING
Label > A
Base > Hex
-0028 4E75
-0027 61E6
-0026 0000
-0025 88C8
-0024 B03C
-0023 O0FF
-0022 6730
-0021 48E7
-0020 4E75
-0019 3000
-0018 0000
-0017 8930
-0016 B03C
-0015 O0FF
-0014 67F8
-0013 B03C
-0012 61FA
-0011 B03C
-0010 0000
-0009 8930
-0008 4EFA
-0007 FF9A
-0006 61E6
-0005 B03C
-0004 0000
-0003 0000
-0002 0000
-0001 0000
+0000 8930
```

Figure 10-16. State Listing Example

Anystate was stored while the analyzer looked for five occurrences of the state **B03C**. After the fifth occurrence was found, only state **0000** was stored until state **8930** was found, and the analyzer triggered. After the trigger, no states were stored.

Acquisition Fields

The acquisition fields are comprised of the Trace mode, Armed by Branches, Count, and Prestore fields, as shown below.

The screenshot shows a menu titled "MACHINE 2 - State Trace Specification". At the top, "Trace mode" is set to "Single". Below this is a "Sequence Levels" section with two levels: Level 1 is "While storing 'any state' Trigger an 'a' | times" and Level 2 is "Store 'any state'". To the right of the sequence levels are several control fields: "Armed by" (Run), "Branches" (Off), "count" (Off), and "Prestore" (Off).

MACHINE 2 - State Trace Specification	
Trace mode	Single
Sequence Levels	
1	While storing "any state" Trigger an "a" times
2	Store "any state"
Armed by	Run
Branches	Off
count	Off
Prestore	Off

Figure 10-17. State Trace Acquisition Fields

Trace Mode

You specify the mode in which the state analyzer will trace with the Trace **mode** field. You have two choices for trace mode: Single and Repetitive. If you place the cursor on the field and press SELECT the field toggles from one mode to the other.

Single Trace mode acquires data once per trace. Repetitive Trace mode repeats single acquisitions until the STOP key on the front panel is pressed, or if Stop measurement is on, until conditions specified with the X and 0 markers in the State Listing menu are met.

If both analyzers are on, only one trace mode can be specified. Specifying one trace mode for one analyzer sets the same trace mode for the other analyzer.

Armed By

The **Armed by** field lets you specify how your state analyzer is to be armed. The analyzer can be armed by the RUN key, the other analyzer, the scope or an external instrument through the BNC Input port. Any of these can tell the analyzer when to start capturing data.

When you select the Armed **by** field, a pop-up menu appears like that shown below. The first two options always appear in the pop-up. The third and fourth options will give the name of the other analyzer and scope. If the other analyzer or scope is off, or if the other machine or scope is being armed by this machine, these options will not be available.

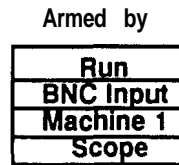

Figure 10-18. Armed By Pop-Up Menu

Branches The Branches field allows you to configure the sequencer of the state analyzer to branch from one sequence level to another with secondary branching qualifiers, or to restart when a certain condition is met. Selecting this field gives you the following pop-up menu.

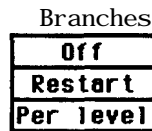

Figure 10-19. Branches Pop-Up Menu

Off

If you select Off, all secondary branching qualifiers are deleted from the sequence levels. Only the primary branches remain.

Restart

The Restart option allows you to start over from sequence level 1 when a specified condition is met. This can be handy if you have code that branches off in several paths and you want the analyzer to follow one certain path. If the analyzer goes off on an undesired path, you would want the analyzer to stop and go back to the beginning and take the correct path.

If you select the Restart option, you will see a qualifier pop-up menu like that shown in **figure 10-2**. With the pop-up you select the qualifier for the pattern on which you want your analyzer to start over.

When your state analyzer is reading data it proceeds through the sequence. If a term doesn't match the branching qualifier, it is then checked against Restart. If the term matches, the state analyzer jumps back the sequence level 1.

Per Level

Selecting the Per level option allows you to define a secondary branching qualifier for each sequence level. A statement is added in each level so that you can configure the analyzer to move to a different level when a specified condition is met. An example of a sequence level with a secondary branching **qualifier** is shown in the figure below.

```
Sequence Level 2 [Done]
-----
Insert Level 1 | Delete Level
-----
While storing [ b ]
Then find [ c ] → [ 1 ] times
Else on [ f ] got0 level [ 4 ]
```

Figure W-20. Secondary Branching Qualifier

With this configuration, the state analyzer will store b until it **finds** c. If it **finds** f before it finds c, it will branch to sequence level 4. If you have specified a storage macro in the next to last sequence level the Else on statement will not appear in that level since a secondary branching qualifier already exists for that level.

In the last sequence level, which only specifies states that are to be stored, the secondary branching qualifier statement looks like that shown below.

Sequence Level 7		(Done)
Insert Level		Delete Level
	Store	any state
On	a	got 0 level 6

Figure 10-21. Secondary Branch Qualifier in Last Level

In this example, as the state analyzer stores anystate, it will branch to sequence level 6 if it finds the state given by qualifier a.

The trigger sequence level is used as a boundary for branching between levels. This level and the levels that occur before it cannot branch to levels that occur after the trigger level, and vice versa. Therefore, if there are eight sequence levels and level 5 is the trigger sequence level, then levels 1 through 5 can branch to levels 1 through 5 only, and levels 6 through 8 can branch to levels 6 through 8 only.

You can tell if secondary branch qualifiers have been specified by looking at the Sequence Levels display. Figure 10-22 shows how the display looks with the configuration that was given in figure 10-20. An arrow is drawn out of level 2, indicating that branching originates from that level, and an arrow is drawn to level 4 to indicate that a branch is going to that level.

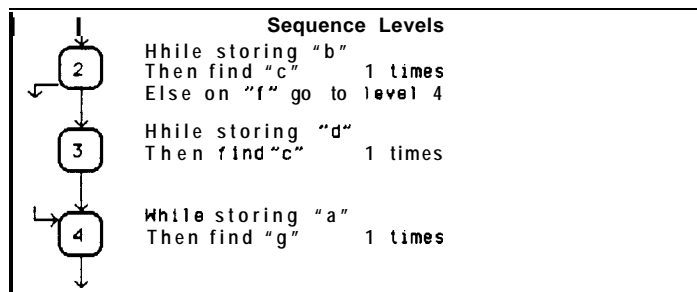

Figure 10-22. Branching Between Sequence Levels

Each sequence level can branch to only one level through a secondary branching qualifier. However, the number of times to which a level can be branched is limited only by the number of levels present. A level can have only one arrow pointing away from it, but it can have two pointing to it if more than one other level is branching to it. An example of this is shown in the figure below. The arrow with two tails indicates that a level above and a level below branch to this level.

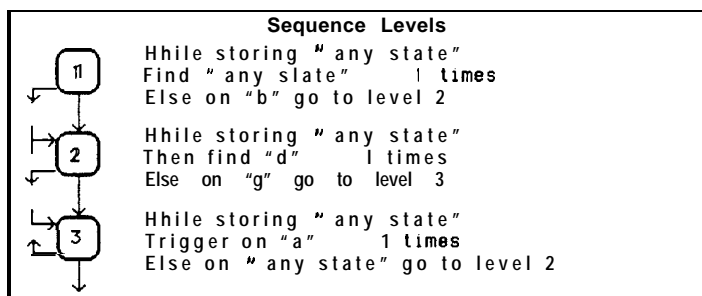

Figure 10-23. Multiple Branching Between Levels

Count The Count field allows you to place tags on states so you can count them. Counting cuts the acquisition memory in half from 1k to 512 and the maximum clock rate is reduced to 16.67 MHz.



Count (State Trace menu) is turned off when “Clock Period” is set to < 60 ns in the State Format Specification menu since the clock rate is greater than 16.67 MHz. If you select Count, the clock period automatically changes to > 60 ns.

Selecting this **field** gives you the following pop-up menu.

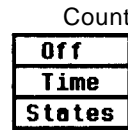

Figure 10-24. Count Pop-Up Menu

Off

If you select Off, the states are not counted in the next measurement.

Time

If you select Time counting, the time between stored states is measured and displayed (after the next run) in the State **Listing** under the label Tie. The time displayed can be either relative to the previous state or to the trigger. The maximum time between states is 48 hours.

An example of a state listing with time tagging relative to the previous state is shown in figure 10-25.

6B000STATE - State Listing		
Markers <input type="checkbox"/> Off		
Label >	DATA	Time
Base >	Hex	Rel
-0007	00FF	1.24 uS
-0006	6730	1.26 uS
-0005	4BE7	1.24 uS
-0004	4E75	1.72 uS
-0003	3000	1.26 uS
-0002	0000	1.24 uS
-0001	8930	1.24 uS
+0000	803C	1.24 uS
+0001	00FF	1.24 uS
w002	67FB	1.28 uS
+0003	803C	1.24 uS
+0004	61FA	1.72 uS
+0005	803C	1.26 uS
+0006	0000	1.96 uS
+0007	6930	1.52 uS
+0008	4EFA	1.24 uS

Figure 10-25. Relative Time Tagging

An example of a state listing with time tagging relative to the trigger is shown below.

6B000STATE - State Listing		
Markers <input type="checkbox"/> Off		
Label >	DATA	Time
Base >	Hex	Abs
0007	00FF	-9.24 uS
-0006	6730	-7.96 uS
-0005	4BE7	-6.72 uS
-0004	4E75	-5.00 uS
-0003	3000	-3.72 uS
-0002	0000	-2.48 uS
-0001	6930	-1.24 uS
+0000	803C	0 uS
+0001	00FF	1.24 uS
+0002	67FB	2.52 uS
+0003	803C	3.76 uS
+0004	61FA	5.46 uS
+0005	803C	6.76 uS
+0006	0000	8.72 uS
+0007	6930	10.24 uS
+0008	4EFA	11.48 uS

Figure 10-26. Absolute Time Tagging

States

State tagging counts the number of qualified states between each stored state. If you select this option, you will see a qualifier pop-up menu like that shown in figure 10-2. You select the qualifier for the state that you want to count.

In the State Listing, the state count is displayed (after the next run) under the label States. The count can be relative to the previous stored state or to the trigger. The maximum count is $4.4 \times 10E12$.

An example of a state listing with state tagging relative to the previous state is shown below.

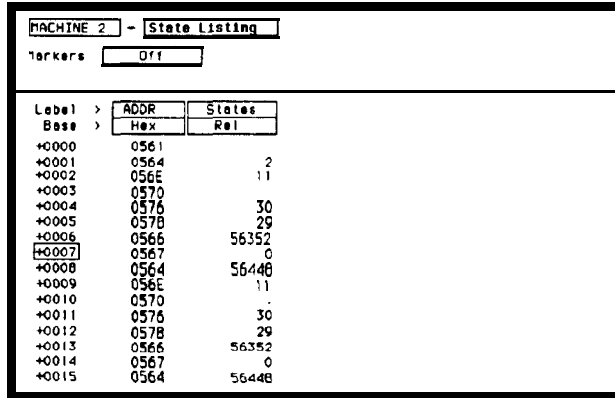

Label	Base	ADDR	Hex	States	Rel
+0000		0561			
+0001		0564		2	
+0002		056E		11	
+0003		0570			
+0004		0576		30	
+0005		0578		29	
+0006		0566		56352	
+0007		0567		0	
+0008		0564		56448	
+0009		056E		11	
+0010		0570			
+0011		0576		30	
+0012		0578		29	
+0013		0566		56352	
+0014		0567		0	
+0015		0564		56448	

Figure 10-27. Relative State Tagging

An example of a state listing with state tagging relative to the trigger is shown below.

Label	Base	States	
		Hex	Abs
+0000		0561	0
+0001		0564	2
+0002		056E	13
+0003		0570	14
+0004		0576	44
+0005		0578	73
+0006		0566	56425
+0007		0567	56425
+0008		0564	112673
+0009		056E	112684
+0010		0570	112685
+0011		0576	112915
+0012		0578	112944
+0013		0566	169296
+0014		0567	169296
+0015		0564	225744

Figure 10-28. Absolute State Tagging

Prestore Prestore allows you to store two qualified states before each state that is stored. There is only one **qualifier** that enables prestore for each sequence level. If you select this field, you will see a pop-up with the options Off and On . Selecting On gives you a qualifier pop-up menu like that in figure 10-2, from which you choose the pattern range or combination of patterns and ranges that you want to prestore.



Note Prestore is only available when clock period is > 60 ns. If you select Prestore, the clock period automatically changes to > 60ns if it was previously set to < 60 ns.

During a measurement, the state analyzer stores in prestore memory occurrences of the states you specify for prestore. A maximum of two occurrences can be stored. If there are more than two occurrences previous ones are pushed out. When the analyzer **finds** a state that has been specified for storage, the prestore states are pushed on top of the stored state in memory and are displayed in the State Listing.

Qualifier and Pattern Fields

The qualifier **and** pattern fields appear at the bottom of the State Trace **Specification** menu. They allow you to specify patterns for the qualifiers that are used in the sequence levels.

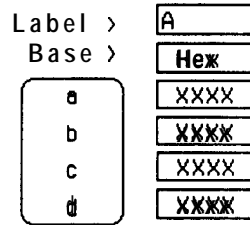

Figure 10-29. Qualifier and Pattern Fields

Label The **Label** fields display the labels that you specified in the State Format Specification menu. The labels appear in the order that you specified them; however, you can change the order. Select one of the label fields and you will see a pop-up menu with all the labels. Decide which label you want to appear in the label field and select that label. The label that was there previously switches positions with the label you selected from the pop-up.

Base The **base** fields allow you to specify the numeric base in which you want to **define** a pattern for a label. The base fields also let you use a symbol that was **specified** in the State Symbol Table for the pattern. Each label has its own base defined separately from the other labels. If you select one of the base fields, you will see the following pop-up menu. Decide which base you want to **define** your pattern in and select that option.

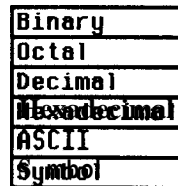

Figure 10-30. Numeric Base Pop-Up Menu

One of the options in the Base pop-up is ASCII . It allows you to see the ASCII characters that are represented by the pattern you specify in the pattern fields.

Note 

You cannot define ASCII characters directly. You must first **define** the pattern in one of the other numeric bases; then you can switch the base to ASCII to see the ASCII characters.

The Symbol option in the Base pop-up allows you to use a symbol that has been specified in the State Symbol Tables as a pattern. In the pattern fields you specify the symbols you want to use.

Qualifier Field

If you select the qualifier field, you will see the following pop-up menu.

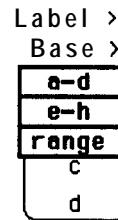

Figure 10-31. Qualifier Field Pop-Up Menu

Patterns

The pattern recognizers are in two groups of four: a-d and e-h. If you select one of these two options, the **qualifier** field will contain only those pattern recognizers. For instance, the **qualifier** field in figure 10-29 contains only the recognizers a-d.

Ranges

If you select the range option, the qualifier and pattern fields look similar to that shown below.

Label >	A
Base >	Hex
Range	
lower	0000
upper	FFFF

Figure 10-32. Range Qualifier and Pattern Fields

Only one range can be defined, and it can be defined over only one label, hence over only 32 channels. The channels do not have to be adjacent to each other. The logic analyzer selects the label over which the range will be defined by looking at the labels in order and choosing the first one that has channels assigned under only two pods. A label that contains channels from more than two pods cannot be selected for range definition. If all the labels have channels assigned under more than two pods, the range option is not offered in the qualifier field pop-up menu. However, in the HP 1653B, the range option will always be offered since the analyzer has only two pods.

Pattern Fields

The pattern fields allow you to specify the states that you want the state analyzer to search for and store. Each label has its own pattern field that you use to specify a pattern for that label (if you are defining a pattern for a pattern **recognizer**).

During a run, the state analyzer looks for a specified pattern in the data. When it **finds** the pattern, it either stores the state or states or it triggers, depending on the step that the sequencer is on.

State Listing Menu

Introduction

This chapter describes the State Listing menus and how to interpret it. It also tells you how to use the fields to manipulate the displayed data so you can **find** your measurement answers. The State **Listing** menu is the display menu of the state analyzer.

There are two different areas of the state listing display, the menu area and the listing area. The menu area is in the top one-fourth of the screen and the listing area is the bottom three-fourths of the screen.

The listing area displays the data that the state analyzer acquires. The data is displayed in a listing format as shown below.

Label	Base	ADDR	DATA	Time
		Hex	Hex	Rel
-0007		0088CA	00FF	1.24 us
-0006		0088CC	6730	1.28 us
-0005		0088CE	4E7	1.24 us
-0004		0088FE	4E75	1.72 us
-0003		006900	3000	1.28 us
-0002		0004F4	0000	1.24 us
-0001		0004F6	8930	1.24 us
0000		006930	803C	1.24 us
+0001		006932	00FF	1.24 us
+0002		008934	67F8	1.28 us
+0003		006936	803C	1.72 us
+0004		00892E	61FA	1.28 us
+0005		006930	803C	1.28 us
+0006		0004F4	w o o	1.96 us
+0007		0004F6	6930	1.52 us
+0008		00892A	4EFA	1.24 us

Figure 1 I-I. State Listing Menu

This listing display shows you 16 of the possible 1024 lines of data at one time. You can use the ROLL keys and the KNOB to roll the listing to the lines of interest.

The column of numbers at the far left represents the location of the acquired data in the state analyzer's memory. The trigger state is always 0000. At the vertical center of this column you will see a box containing a number. The box is **used** to quickly select another location in the state listing. The rest of the columns (except the Time/States column) represent the data acquired by the state analyzer. The data is grouped by label and displayed in the number **base you** have selected (hexadecimal is the default base).

When the Tie or States option is selected in the Count field (State Trace **Specification** Menu), the acquired data will be displayed with time or state tags.

The Time column displays either the **Rel(ative)** time (time from one state to the next) or **Abs(olute)** time (time from each state to the trigger).

The States column displays the number of qualified states **Rel(ative)** to the previously stored state or the trigger (absolute).

Accessing the State Listing Menu

The State Listing Menu is accessed by pressing the DISPLAY key on the front panel when the state analyzer is on. It will automatically be displayed when you press RUN. If the Tiig Waveforms is displayed when you press the DISPLAY key, you **will** have to switch analyzers. This is not a problem, it merely indicates that you were in the timing analyzer or you had performed an action to the timing analyzer in the System Con&ration Menu.

State Listing Menu Fields

The menu area contains fields that allow you to change the display parameters, place markers, and display listing measurement parameters.

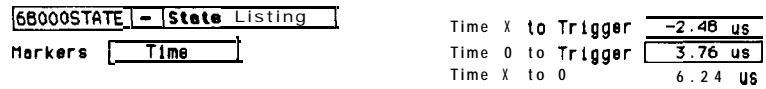

Figure 11-2. State Listing Menu Fields

Markers

The **Markers** field allows you to specify how the X and 0 markers will be positioned on the state listing. The State Trace Specifications menu options are:

If Count in the State Trace menu is Off, the marker options are:

- off
- Pattern

If Count in the State Trace menu is set to Time, the marker options are:

- off
- Pattern
- Time
- Statistics

If Count in the State Trace menu is set to State, the marker options are:

- off
- Pattern
- State

Markers Off

When the markers are off they are not displayed, but are still placed at the specified points in the data. If Stop measurement is on and the Stop measurement criteria are present in the data, the measurement will stop even though the markers are off.

Markers Patterns

When the markers are set to patterns, you can specify patterns on which the logic analyzer **will** place the markers. You can also specify how many occurrences of each marker pattern the logic analyzer looks for. This use of the markers allows you to **find** a specific pattern for each label in the acquired data.



Figure 11-3. Markers Set to Patterns

Patterns for each marker (X and 0) can be specified. They can be specified for both markers in each label. The logic analyzer searches for the logical “and” of patterns in all labels.

In the **Find X (0)-pattern 0 from Trigger** field you specify how many occurrences of the marked pattern from a reference point you want the logic analyzer to search for. The reference points are:

- Trigger
- Start (of a trace)
- X Marker (only available in 0 marker pattern specification)

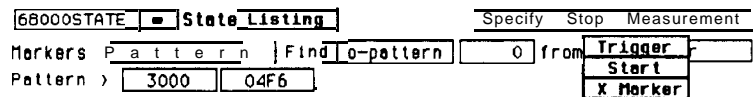

Figure 11-4. Search Reference Pop-Up Menu

Stop Measurement

Another feature of markers set to patterns is Stop Measurement. You can specify either stop measurement when X-O is _____ or Compare is _____. The options for X-O are: Less than, Greater than, In range, Not in range. The options for Compare are: Equal and Not Equal (see figure 11-5).

Stop Measurement Parameters		Done
Stop measurement	X-O is	Less than 10 ns
Store exception to disk:	On	File name EXCEPTION
File description		

Figure 11-5. Markers Patterns Pop-Up Menu

With this feature you can use the logic analyzer to look for a specified time or range of time between the marked patterns and to stop acquiring data when it finds this time between markers. The X marker must precede the O marker.

Also available is **Store exception to disk** which allows you to specify a file on the disk that exceptions can be stored in. The default filename is EXCEPTION. When the trace mode is repetitive and Store exception to disk is on, the following process takes place: data is acquired until the stop criteria is met, data acquisition **will** stop, data in the acquisition memory **will** be stored on the disk, and data acquisition will resume when the data is stored. This process continues until the disk is full. The data is stored in the same file name; however, the last three characters will automatically be replaced with a numerical serial number. For example, EXCEPTION will change to EXCEPT001 the second time memory is stored.



The upper and lower range boundaries must not be the same value. For example, if you want to stop a measurement when the X and O markers are in range of 200 ns, you should set the range values to 190 ns and 210 ns. This eliminates erroneous measurement termination.

Markers Time When the markers are set to Tie, you can place the markers on states in the listing of interest and the logic analyzer will show the following:

- Time X to **Trig(ger)**.
- Time 0 to **Trig(ger)**.
- **Time X to 0**.

To position the markers, move the cursor to the field of **the** marker you wish to position and press SELECT. A pop-up will appear showing the current time for that marker. Either rotate the KNOB or enter a numeric value from the keypad to change the position of that marker. Pressing SELECT when you are finished positions the marker and closes the pop-up.



Figure 11-6. Markers Set to Time

The Tie X to 0 field will change according to the position of the X and 0 markers. It displays the total time between the states marked by the X and 0 markers.

Markers Statistics When statistics are specified for markers, the logic analyzer will display the following:

- Number of total runs.
- Number of valid runs (runs where markers were able to be placed on specified patterns).
- Minimum time between the X and 0 markers * Maximum time between the X and 0 markers.
- Average time between the X and 0 markers.

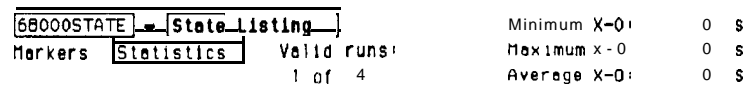

Figure 11-7. Markers Set to Statistics

How the statistics will be updated depends on the state trace mode (repetitive or single).

In repetitive, statistics will be updated each time a valid run **occurs** until you press STOP. When you press RUN after STOP, the statistics will be cleared and will restart from zero.

In single, each time you press RUN an additional valid run will be added to the data and the statistics will be updated. This will continue unless you change the placement of the X and 0 markers between runs.

Pattern ___ Field You use the Pattern ___ field to specify the patterns for the X and 0 markers for each label.

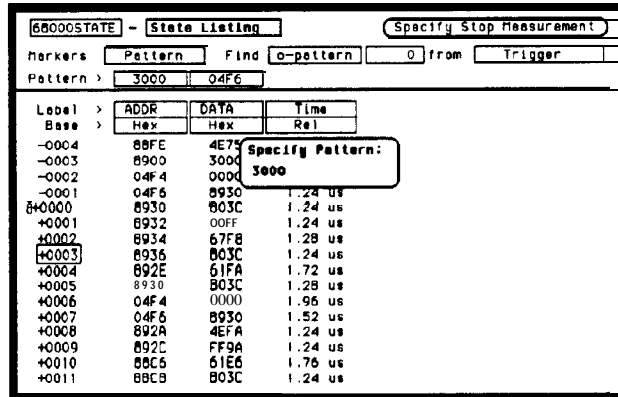

Figure 11-8. Pattern ___ Field Pop-Up Menu

When x-pattern is specified in the **Find ___ from ___ field**, the pop-ups in the Pattern ___ field allow you to **specify** a pattern for the X marker in each label.

When the O-pattern is specified, the pop-ups in the Pattern ___ field allow you to specify the patterns for the 0 marker in each label.

State Compare Menu

Introduction

State compare is a software post-processing feature that provides the ability to do a bit by bit comparison between the acquired state data listing and a compare data image. You can view the acquired data and the compare image separately. In addition, there is a separate difference listing that **highlights** the bits in the acquired data that do not match the corresponding bits in the compare image. Each state machine has its own Compare and Difference listings.

You can use the editing capabilities to modify the compare image. Masking capabilities are provided for you to specify the bits that you do not want to compare. "Don't compare" bits can be specified individually for a given label and state row, or specified by channel across all state rows. A range of states can be selected for a comparison. When a range is selected, only the bits in states on or between the specified boundaries are compared.

The comparison between the acquired state listing data and the compare image data is done relative to the trigger points. This means that the two data records are aligned at the **trigger** points and then compared bit by bit. Any bits in the acquired data that do not match the bits in the compare image are treated as unequal. The don't compare bits in the compare image are ignored for the comparison.

When a logic analyzer configuration is saved to or loaded from a disk, any valid compare data including the data image, etc. is also saved or loaded.

Accessing the Compare Menu

The Compare menu is accessed from the State Listing menu. To access the Compare menu place the cursor on the field State **Listing** and press **SELECT**. A pop-up appears with the following options:

- State Listing
- State Waveforms
- State Chart
- State Compare

Place the cursor on State **Compare** and press **SELECT**. The pop-up will close and display the State Compare menu.

The Compare and Difference Listing Displays

Two menus (or displays) in addition to the normal State **Listing**, are available for making comparison measurements: the Compare **Listing** and the Difference Listing.

The Compare Listing

The Compare Listing contains the image (or template) that acquired data is compared to during a comparison measurement. The boundaries of the image (or size of the template) can be controlled by using the channel masking and compare range functions described below. Any bits inside the image displayed as "**X**" have been set to don't compare bits.

The Difference Listing

The Difference Listing **highlights** the entire row with inverse video, if any, in the acquired data that differs from those in the compare image. In addition, when the base is hexadecimal, octal, or binary, the bit (or digit containing the bit) that differs from the compare image is underlined (see figures 12-2 and 12-3). If the base is inverse assembled symbols, the display does not change; however, the stop measurement functions still function.

To display the Compare Listing or the Difference Listing, place the cursor on the field directly to the right of **Show** in the upper left part of the display and press **SELECT**. The field **will** toggle between **Compare Listing** and **Difference Listing**.

The controls that roll the listing in all three menus, the normal State Listing, the Compare Listing, and the Difference Listing are synchronized unless the number of pre-trigger states differ between the Compare listing and the acquired data. This means that when you change the current row position in the Difference **Listing**, the logic analyzer automatically updates the current row in the acquired State Listing, Compare Listing and vice-versa.

If the three listings are synchronized and you re-acquire data, the Compare Listing may have a different number of pre-trigger states depending on the state trace trigger criteria. The Compare Listing can be **resynchronized** to the State and Difference Listings (if different) by entering the desired state (acquisition memory) location from the front-panel keypad.

This allows you to view corresponding areas of the two lists, to cross check the alignment, and analyze the bits that do not match.

Since time tags are not required to perform the compare, they do not appear in either the compare image or difference displays. However, correlation is possible since the displays are locked together.

To move between the State Listing and Compare Listing in the HP **1652B/53B**, select the field directly to the right of your state machine's label, in the upper left most part of the screen and press **SELECT**. When this **field** is selected., a pop-up **will** appear. Select the State Listing field from this pop-up.

Creating a Compare Image

An initial compare image can be generated by copying acquired data into the compare image buffer. When you place the cursor on the **Copy Trace to Compare field** in the Compare Listing menu a pop-up appears with the options **Cancel** and **Continue**. If the **Continue** is selected, the contents of the acquisition data structure for the current machine are copied to the compare image buffer. The previous compare image is lost if it has not been saved to a disk. If you select **Cancel** the current compare image remains unchanged.

Bit Editing of the Compare Image

Bit editing allows you to modify the values of individual bits in the compare image or specify them as don't compare bits. The bit editing fields are located in the center of the Compare Listing display to the right of the listing number field (see figure 12-1). A bit editing field exists for every label in the display unless the label's base is ASCII or inverse assembled symbols. You can access any data in the Compare Listing by rolling the desired row vertically until it is located in the bit editing field for that label (column).

When you select one of the bit editing fields a pop-up appears in which you enter your desired pattern or don't compare for each bit.

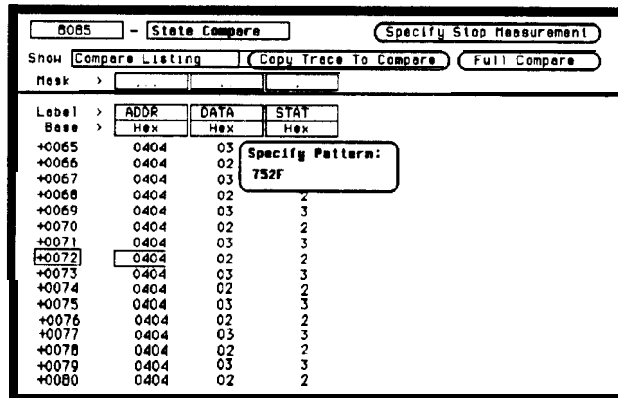

Figure 12-1. Bit Editing Fields

Masking Channels in the Compare Image

The channel masking function allows you to specify a bit, or bits in each label that you do not want compared. This causes the corresponding bits in all states to be ignored in the comparison. The compare data image itself remains unchanged on the display. The Mask fields are directly above the label and base fields at the top of both the Compare and Difference listings (see **figure12-2**). When you select one of these fields a pop-up appears in which you specify which channels are to be compared and which channels are to be masked. A "." (period) indicates a don't compare mask for that channel and an "*" (asterisk) indicates that channel is to be compared.

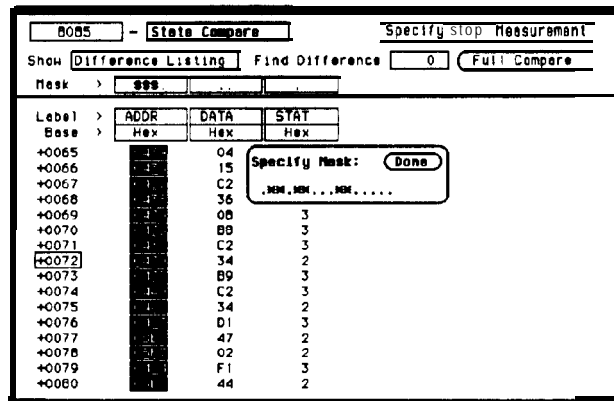

Figure 12-2. Bit Masking Fields

Specifying a Compare Range

The Compare Range function allows you to define a subset of the total number of states in the compare image to be used in the comparison. The range is specified by setting start and stop boundaries. Only bits in states (lines) on or between the boundaries are compared against the acquired data.

The Compare mode is accessed by selecting the **Full Compare/Partial Compare field** in either the Compare or Difference listing menus. When selected, a pop-up appears in which you select either the **Full** or **Partial** option. When you select the Partial option, fields for setting the start state and stop state values appear (see figure 12-3).

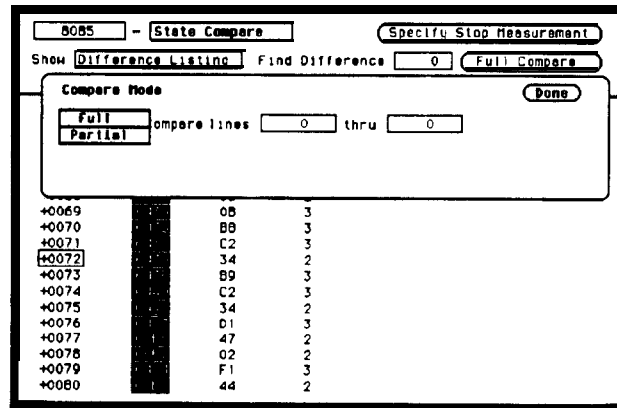

Figure 12-3. Compare Full/Compare Partial Field

Repetitive Comparisons with a Stop Condition

When you do a comparison in **the** repetitive trace mode, a stop condition may be specified. The stop condition is either **Stop Measurement** when Compare is **Equal** or **Not Equal**. In the case of Equal, bits in the compare image must match the corresponding bits in the acquired data image for the stop condition to be a true. In the case of Not Equal, a mismatch on a single bit will cause the stop condition to be true. When stop conditions are specified in two analyzers, both analyzers stop when the stop condition of either analyzer is satisfied. It is an OR function.

You access the stop measurement function by selecting the **Specify Stop Measurement** field in either the Compare or Difference Listing menus. When you select this **field**, the Stop Measurement Parameters pop-up appears (see figure 12-4). The first field in this pop-up, just to the right of Stop measurement contains either **Off**, **X-O** or **Compare**.

When this field is selected, a pop-up appears in which you select **Compare**. When you select the Compare option, you can access and select either the **Equal** or **Not Equal** option in the next field to the right.

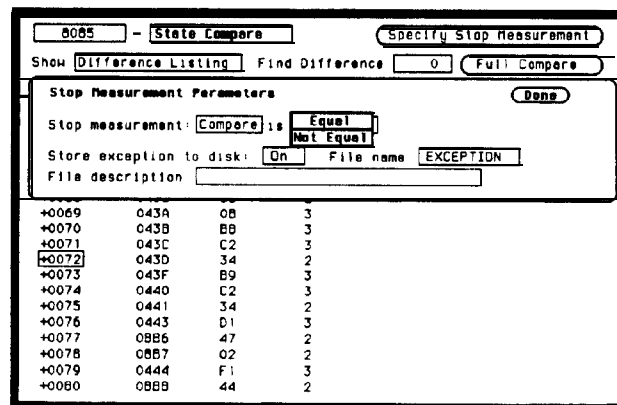

Figure 12-4. Specify Stop Measurement Field

Also available is **Store exception to disk** which allows you to specify a file on the disk that exceptions can be stored in. The default filename is EXCEPTION.

When the trace mode is repetitive and Store exception to disk is on, the following process takes place: data is acquired until the stop criteria is met, data acquisition will stop, data in the acquisition memory will be stored on the disk, and data acquisition will resume when the data is stored. This process continues until the disk is full. The data is stored in the same **file** name; however, the last three characters will automatically be replaced with a numerical serial number. For example, EXCEPTION will change to EXCEPT001 the second time memory is stored.

Note 

You may also specify a stop measurement based on time between the X and 0 markers in the Compare or Difference Listing menus. This is available only when **Count** is set to **Time** in the State Trace menu. If the Stop Measurement is set to run until Compare Equal or Compare Not Equal in the Compare or Difference Listings, the Stop Measurement on time X to 0 will change to run until Compare Equal or Compare Not Equal in the other state display menus (i.e. State Listing).

Locating Mismatches in the Difference Listing

The **Find Difference** feature allows you to easily locate any patterns that did not match in the last comparison. Occurrences of differences are found in numerical ascending order from the start of the listing. The first occurrence of an error has the numerical value of one.

This feature is controlled by the **Find Difference** ___ field in the Difference Listing menu. When you select this **field an** Integer Entry pop-up appears in which you enter a number indicating which difference you want to find. The listing is then scanned sequentially until the **specified** occurrence is found and rolled into view.

Saving Compare Images

When you save a logic analyzer configuration to a disk, the compare images for both state analyzers are saved with it. The compare data is compacted to conserve disk space. Likewise, when you load a configuration from disk, **valid** compare data will also be loaded.

State Chart Menu

Introduction

The State Chart Menu allows you to build X-Y plots of label activity using state data. The Y-axis **always** represents data values for a specified label. You can select whether the X-axis represents states (ie. rows in the State **List**) or the data values for another label. You can scale both the axes to selectively view data of interest. An accumulate mode is available that allows the chart display to build up over several runs. When **State** is selected for the X-axis, X & 0 markers are available which allows the current sample (state or time) relative to trace point and the corresponding Y-axis data value to be displayed. Marker placement is synchronized with the normal State Listing.

Accessing the State Chart Menu

The Chart menu is accessed from the State Listing menu. To access the Chart menu place the cursor on the field **State Listing** and press SELECT. A pop-up appears with the following options:

- State **Listing**.
- State Waveforms.
- State Chart.
- State Compare.

Place the cursor on State Chart and press SELECT. The pop-up will close and display the State Chart menu.

Selecting the Axes for the Chart

When using the State Chart display, you **first** select what data you want plotted on each axis. To assign the vertical axis label, position the cursor on the Y-axis **Label** field in the menu. This is the field just to the right of "XY Chart of Label". When selected, a pop up appears in which you select one of the labels that were defined in the State Format Specification Menu. The X-axis assignment field is just to the right of "**Versus**", and toggles between State and Label when selected. When label is selected, a third field appears to the right of **Label** that pops up when selected in which you select one of the defined state labels.

Scaling the Axes

Either axis of the X - Y chart can be scaled by using the associated vertical or horizontal **min (minimum)** or **max (maximum)** value fields. When selected, a **Specify Number** pop up appears in which you specify the actual minimum and maximum values that **will** be displayed on the chart.

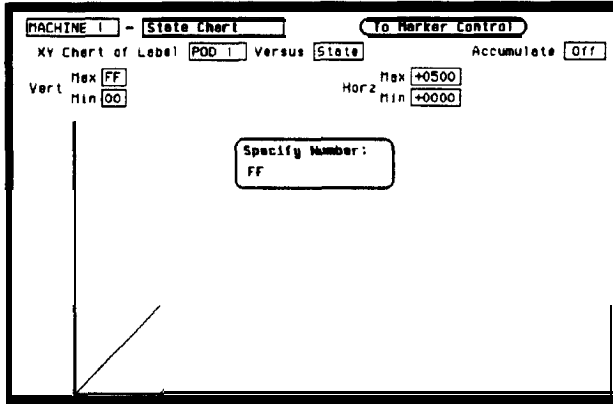

Figure 13-1. Axis Scaling Pop-up Menu

When State is selected for the X-axis, state acquisition memory locations are plotted on the X-axis. The minimum and maximum values can range from -1023 to +1023 depending on the trace point location. The minimum and maximum values for labels can range from **00000000H to FFFFFFFFH** (0 to 2^{32-1}) regardless of axis, since labels are restricted to 32 bits.

The Label Value v s . States Chart

The Label Value versus State chart is a plot of label activity versus the memory location in which the label data is stored. The label value is plotted against successive analyzer memory locations. For example, in the following figure, label activity of POD 1 is plotted on the Y axis and the memory locations (State) are plotted on the X axis.

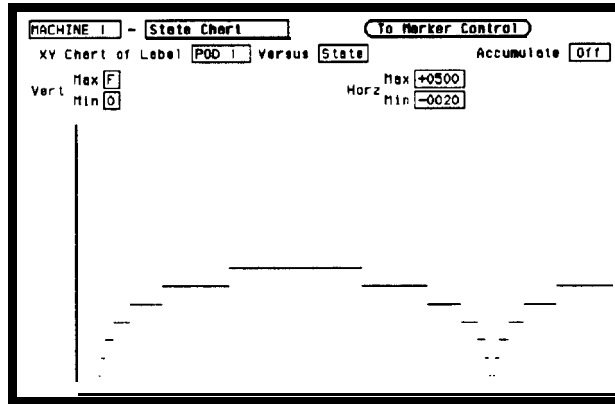

Figure 13-2. Label vs. State Chart

The Label Value

v s .

Label Value Chart

When labels are assigned to both axis, the chart shows how one label varies in relation to the other for a particular state trace record. Label values are always plotted in ascending order from the bottom to the top of the chart and in ascending order from left to right across the chart. Plotting a label against itself **will** result in a diagonal line from the lower left to upper right corner. X & 0 markers are disabled when operating in this mode.

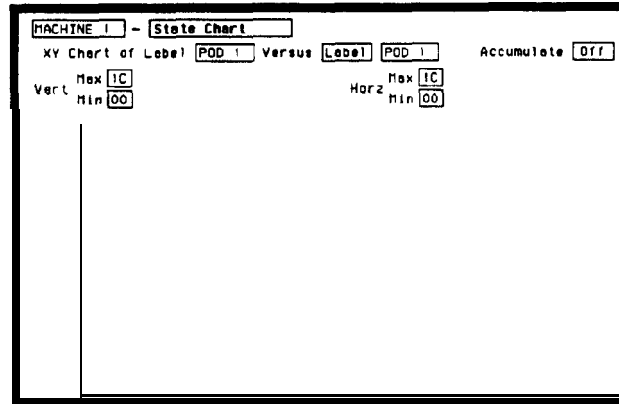

Figure 13-3. Label vs. Label Chart

X & 0 Markers and Readouts for Chart

When State is specified for the X-axis, X & 0 markers are available which can be **moved** horizontally. The markers are synchronized with the X and 0 markers in the normal State Listing.

To select the marker mode for Chart (if it is not presently displayed), place the **cursor** on the **To Marker Control** field and press SELECT. This field will toggle to **To Range Control** and the marker fields will be displayed (see figure 13-4).

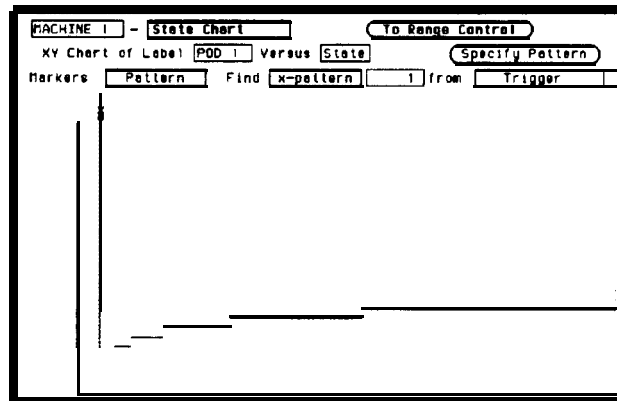

Figure 13-4. Marker Fields

When a marker is positioned in the State Chart menu, it is also positioned in the State Listing menu and vice-versa. The Chart marker operation is identical to the markers in the State Listing menu (see chapter 11).

Marker Options The marker options in the State Chart menu depend on what Count is set to in the State Listing menu.

When Count is set to Off, the Chart markers can be set to:

- off.
- Pattern.

When Count is set to Time, the Chart markers can be set to:

- **Off.**
- Pattern.
- Time.
- Statistics.

When Count is set to **States**, the Chart markers can be set to:

- Pattern.
- States.
- off.

State Waveforms Menu

Introduction

The State Waveforms Menu allows you to view state data in the form of waveforms identified by label name and bit number. Up to 24 waveforms can be displayed simultaneously. Only state data from the current state machine can be displayed as waveforms in the State Waveforms menu.

The presentation and user interface is generally the same as the Timing Waveform menu, except the X-axis of the state waveform display represents only samples, or states instead of time (seconds). This is true regardless of whether **Count** (in the State Trace menu) is set to Time or Off. As a result, the horizontal axis of the display is scaled by **States/Div** and Delay in terms of samples from trigger. Marker features are the same as for State List in that Time or States will only be available when **Count** is set to Time or States. The Sample Rate display is not available in State Waveform even when markers are off.

Accessing the State Waveforms Menu

The State Waveforms menu is accessed from the State Listing menu. To access the State Waveforms menu place the cursor on the State Listing field and press SELECT. A pop-up appears with the following options:

- State Listing.
- State Waveforms.
- State Chart.
- State Compare.

Place the cursor on State Waveforms and press SELECT. The pop-up will close and display the State Waveforms menu.

Selecting a Waveform

You can display up to 24 waveforms on screen at one time. Each waveform is a representation of a **predefined** label. To select a waveform, place the cursor on a label name on the left side of the display and press SELECT. A pop-up appears in which you:

- Insert waveforms.
- Turn on waveforms.
- Modify waveforms (waveform labels).
- Turn off waveforms.
- Delete waveforms.

Just to the right of each label name is a two-digit number or the word “all.” The number indicates which bit of the label the waveform represents; or, all the bits of the label when “all” is displayed (see figure 14-1).

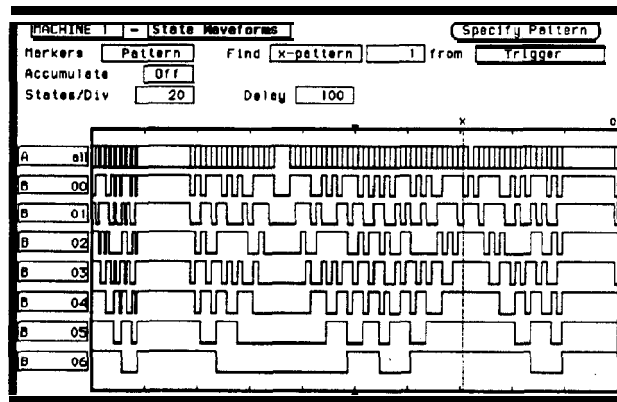

Figure 14-1. State Waveforms Menu

In the above figure, label A has “all” specified displaying all the bits overlaid in a single waveform. Label B however, has seven of its bits displayed **individually** (bits 0 through 6).

Replacing Waveforms

You can replace a currently displayed waveform (label) with another one of the **predefined** waveforms (labels). To replace one waveform with another, place the cursor on the waveform you wish to replace and press **SELECT**. A pop-up appears in which you select **Modify Waveform** as shown in the following figure.

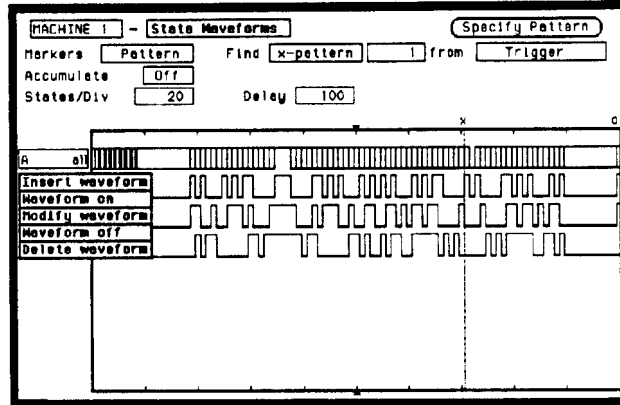

Figure 14-2. Waveform Selection Pop-up Menu

Another pop-up appears in which you select the waveform (label) you wish to display (see figure 14-3). When you place the cursor on the new waveform (label) and press SELECT the new waveform replaces the old waveform.

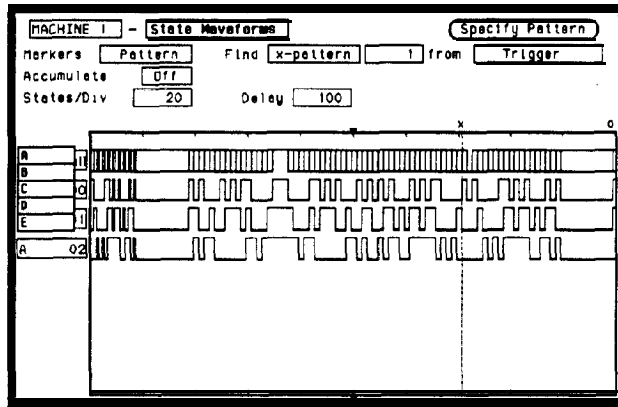

Figure 14-3. Available Waveforms Pop-up Menu

Deleting Waveforms

You can delete any of the currently displayed waveforms by placing the cursor on the waveform you wish to delete and pressing SELECT. When the pop-up appears place the cursor on Delete waveform and press SELECT.

Selecting States per Division

You can specify the states per division by placing the cursor on the field just to the right of **States/Div**, pressing SELECT, and either entering the number of states per division with the keypad or the knob. The range is from 1 to 1024 per division.

Delay from Trigger

You can specify the delay from trigger by **specifying** the number of states from the trigger. The delay will affect only the position of the State Waveforms display. It does not affect data acquisition. The minimum is **- 1024** and the maximum is 1024 independent of trace position in the record. Delay is not limited to the window containing data.

State Waveform Display Features

The waveform display features of the State Waveform menu are the same as the Tuning Waveform menu with regard to:

- **Low** levels (below threshold) are represented by darker line.
- Dotted lines representing the X and 0 markers.
- Inverted triangle representing the trigger point.
- Accumulate Mode.
- Graticule frame with 10 horizontal divisions.

X and 0 Markers for State Waveform

Markers can be placed on the waveform display by specifying the number of states from trigger in the case of the X marker or number of states from either the trigger or X marker in the case of the 0 marker.

Markers can be automatically placed on the waveform by searching for specific patterns assigned to each marker.

The X and 0 marker operation is identical to the marker operation in the Timing Waveform Menu.

State Analyzer Measurement Example

Introduction

In this chapter you learn how to use the state analyzer by setting up the logic **analyzer** to simulate a simple state measurement. Since you may not have the same test circuit available, we will give you the measurement results as actually measured by the logic analyzer,

The exercise in this chapter is organized in a task format. The tasks are in the same order you will most likely use them once you become experienced. The steps in this format are both numbered and lettered. The numbered steps state the step objective. The lettered steps explain how to accomplish each step objective. There is also an example of each menu after it has been properly set up.

How you use the steps depends on how much you remember from chapters 1 through 4 of the **Getting Started Guide**. If you can set up each menu by just looking at the menu picture, go ahead and do so. If you need a reminder of what steps to perform, follow the numbered steps. If you **still** need more information about “how,” use the lettered steps.

To gain confidence using your logic analyzer, we recommend that you configure the menus as you follow the simulated measurement example up to the section “Acquiring the Data.” From that section to the end, you will see the measurement results on the State Listing screen as if you had the real test circuit connected, and as if you had selected RUN.

Problem Solving with the State Analyzer

In this example assume you have designed a microprocessor controlled circuit. You have completed the hardware, and the software designer has completed the software and programmed the ROM (read-only memory). When you turn your circuit on for the first time, your circuit doesn't work properly. You have checked the power supply voltages and the system clock and they are working properly.

Since the circuit has never worked before, you and the software engineer aren't sure if it is a hardware or software problem. You need to do some testing to **find** a solution.

What Am I Going to Measure?

You decide to start where the microprocessor starts when power is applied. We will describe a **68000** microprocessor; however, every processor has **similar** start-up routines.

When you power up a **68000** microprocessor, it is held in reset for a specific length of time before it starts doing anything to stabilize the power supplies. The time the microprocessor is held in reset ensures stable levels (states) on **all** the devices and buses in your circuit. When this reset period has ended, the **68000** performs a specific routine **called** "fetching the reset vector."

The first thing you check is the time the microprocessor is held in reset. You **find** the time is correct. The next thing to check is whether the microprocessor fetches the reset vector properly.

The steps of the 68000 reset vector fetch are:

1. Set the stack pointer to a location you specify, which is in ROM at address locations 0 and 2.
2. Find the first address location in memory where the microprocessor fetches its first instruction. This is also specified by you and stored in ROM at address locations 4 and 6.

What you decide to find out is:

1. What ROM address does the microprocessor look at for the location of the stack pointer, and what is the stack pointer location stored in ROM?
2. What ROM address does the microprocessor look at for the address where its first instruction is stored in ROM, and is the instruction correct?
3. Does the microprocessor then go to the address where its first instruction is stored?
4. Is the executable instruction stored in the first instruction location correct?

Your measurement, then, requires verification of the sequential addresses the microprocessor looks at, and of the data in ROM at these addresses. If the reset vector fetch is correct (in this example) you will see the following list of numbers in HEX (default base) when your measurement results are displayed.

```
+ 0000 000000 0000
+ 0001 000002 04FC
+ 0002 000004 0000
+ 0003 000006 8048
+ 0004 008048 3E7C
```

This list of numbers will be explained in detail later in this chapter in "The State Listing."

How Do I Configure the Logic Analyzer?

In order to make this state measurement, you must configure the logic analyzer as a state analyzer. By following these steps you will configure Analyzer 1 as the state analyzer.

If you are in the System Configuration menu you are in the right place to get started and you can start with step 2; otherwise, start with step 1.

1. Using the field in the upper left corner of the display, get the System Configuration menu on screen.
 - a. Place the cursor on the field in the upper left corner of the display and press SELECT.
 - b. Place the cursor on System and press SELECT.
2. In the System Configuration menu, change the Analyzer 1 type to State. If Analyzer 1 is already a state analyzer, go on to step 3.

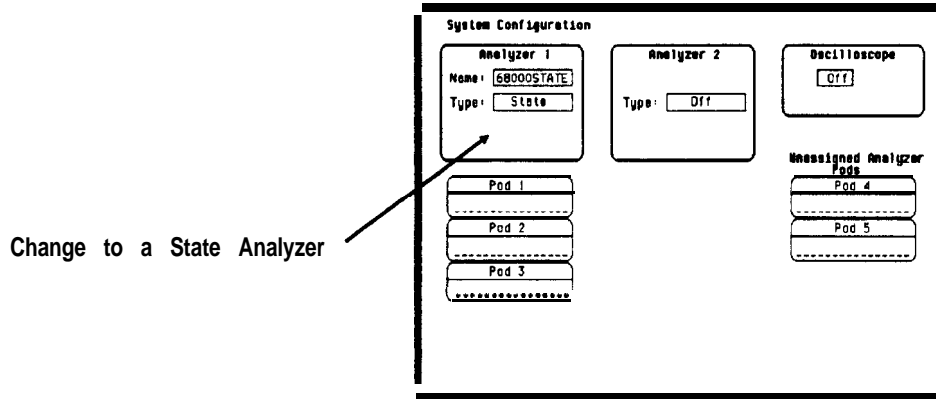

Figure 15-1. System Configuration Menu

- a. Place the cursor on the **Type: ___** and press SELECT.
- b. Place the cursor on State and press SELECT.

3. Name Analyzer 1 **68000STATE** (optional).
 - a. Place the cursor on the Name: field of Analyzer 1 and press **SELECT**.
 - b. With the Alpha Entry pop-up, change the name to **68000STATE**.
4. Assign pods **1, 2,** and 3 to the state analyzer.
 - a. Place the cursor on the Pod 1 field and press **SELECT**.
 - b. In the Pod 1 pop-up, place the cursor on Analyzer 1 and press **SELECT**.
 - c. Repeat steps a and b for pods 2 and 3.

Connecting the Probes

At this point, if you had a target system with a **68000** microprocessor, you would connect the logic analyzer to your system. Since you will be assigning labels ADDR and DATA, you hook the probes to your system accordingly.

- Pod 1 probes 0 through 15 to the data bus lines **D0** through **D15**.
- Pod 2 probes 0 through 15 to the address bus lines **A0** through **A15**.
- Pod 3 probes 0 through 7 to the address bus lines **A16** through **A23**.
- Pod 1, CLK (J clock) to the address strobe (LAS).

Activity Indicators

When the logic analyzer is connected and your target system is running, you will see **Activity Indicators** in the Pod 1, 2, and 3 fields of the System Configuration menu. This indicates which signal lines are transitioning.

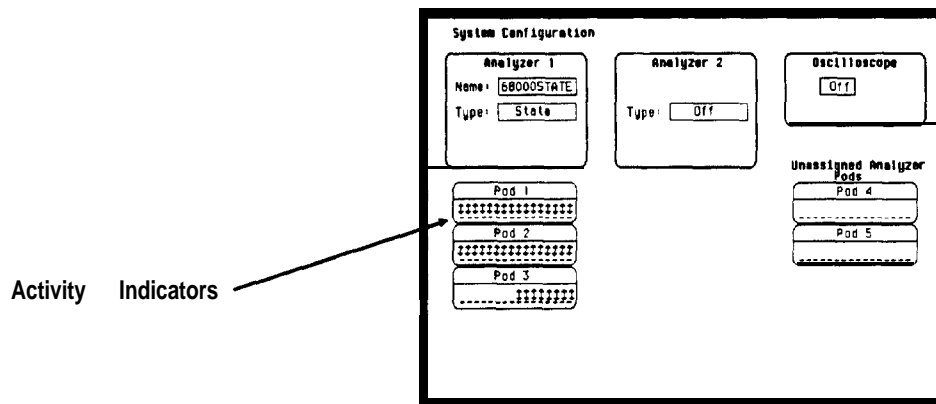

Figure 15-2. Activity Indicators

Configuring the State Analyzer

Now that you have configured the system, you are ready to configure the state analyzer. You **will** be:

- Creating two names (labels) for the input signals
- Assigning the channels connected to the input signals
- Specifying the State (J) clock
- Specifying a trigger condition

1. Display the State Format Specification menu.

a. Press the FORMAT key on the front panel.

2. Name two labels. one ADDR and one DATA.

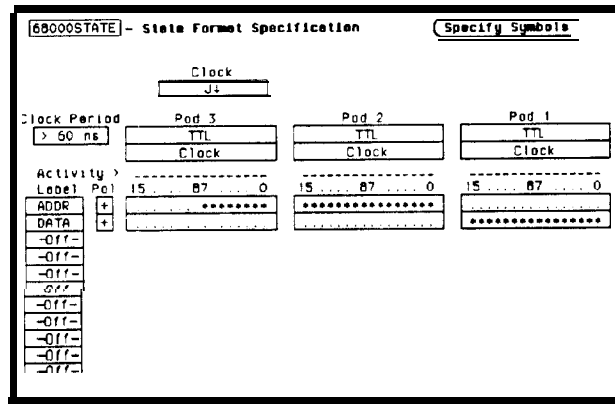

Figure 16-3. State Format Specification Menu

a. Place the cursor on the top field in the label column and press SELECT.

b. Place the cursor on Modify label and press SELECT.

- c. With the Alpha Entry pop-up, change the name of the label to ADDR.
 - d. Name the second label DATA by repeating steps a through c.
3. Assign Pod 1 bits 0 through 15 to the label DATA.
 - a. Place the cursor on the bit assignment field below Pod 1 and to the right of DATA and press SELECT.
 - b. Any combination of bits may already be assigned to this pod; however, you will want all 16 bits assigned to the DATA label. The easiest way to assign is to press the CLEAR ENTRY key to **un-assign** any assigned bits before you start.
 - c. Place the cursor on the period under the 15 in the bit assignment pop-up and press SELECT. This will place an asterisk in the pop-up for bit **15**, indicating Pod 1 bit 15 is now assigned to the DATA label. Repeat this procedure until all 16 bits have an asterisk under each bit number. Place the cursor on Done and press SELECT to close the pop-up.
 - d. Repeat step c for Pod 2 and the **ADDR** label to assign all 16 bits.
 - e. Repeat step c except you will assign the lower eight bits (0 • 7) of Pod 3 to the ADDR label.

Specifying the J Clock

If you remember from “What’s a State Analyzer” in *Feeling Comfortable With Logic Analyzers*, the state analyzer samples the data under the control of an external clock, which is “synchronous” with your circuit under test. Therefore, you must specify which clock probe you will use for your measurement. In this exercise, you will use the J clock, which is accessible through pod 1.

1. Select the State Format Specification menu by pressing the FORMAT key.
2. Set the J Clock to sample on a negative-going edge.

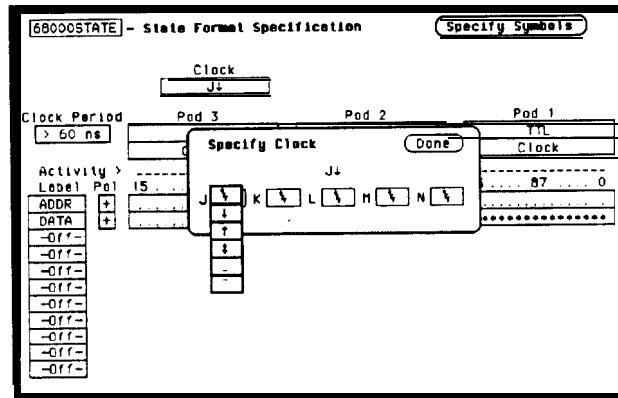

Figure 15-4. Specifying the J Clock

- a. Place the cursor on the CLOCK field and press SELECT.
- b. Place the cursor on the box just to the right of J in the pop-up (labeled OFF) and press SELECT.
- c. Place the cursor on ↓ and press SELECT.
- d. Place the cursor on Done and press SELECT.

Specifying a Trigger Condition

To capture the data and place the data of interest in the center of the display of the State **Listing** menu, you need to tell the state analyzer when to trigger. Since the first event of interest is address **0000**, you need to tell the state analyzer to trigger when it detects address 0000 on the address bus.

1. Select the State Trace Specification menu by pressing the TRACE key.
2. Set the trigger so that the state analyzer triggers on address 0000. If the Trigger on option is not already a perform steps a through d. If the option is a skip to step e.
 - a. Place the cursor on the 1 in the Sequence Levels field of the menu and press SELECT.
 - b. Place the cursor on the 1 in the Sequence Levels field of the menu and press SELECT.

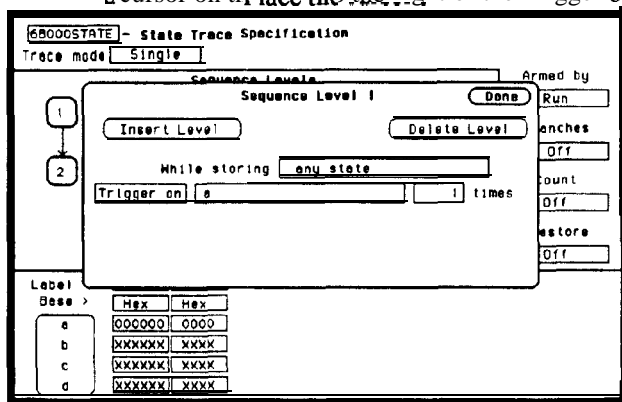

Figure 15-5. State Trace Specification Menu

and press SELECT. Another pop-up appears showing you a list of “trigger on” options. Options **a** through **h** are qualifiers. You can assign them a pattern for the trigger specification.

- c. Place the cursor on the a option and press SELECT.
- d. Place the cursor on Done in the Sequence Levels pop-up and press SELECT.
- e. Place the cursor on the field to the right of the a under the label ADDR and press SELECT.
- f. With the keypad, press 0 (zero) until there are all zeros in the Specify Pattern: pop-up and then press SELECT.

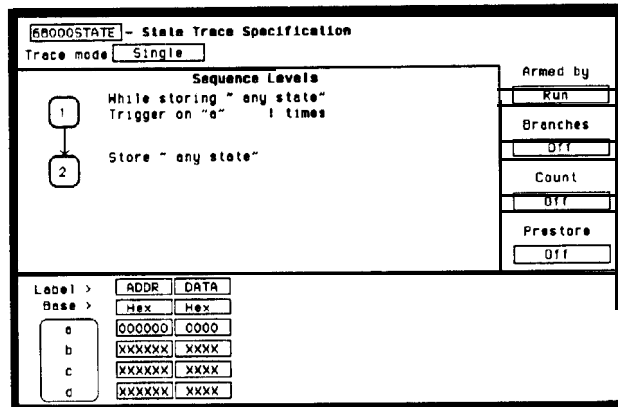

Figure 15-6. State Trace Specification

Your trigger specification now states: “While storing **anystate** trigger on “a” once and then store **anystate**.”

When the state analyzer is connected to your circuit and is acquiring data, it continuously stores until it sees 0000 on the address bus, then it will store **anystate** until the analyzer memory is filled.

Acquiring the Data

Since you want to capture the data when the microprocessor sends address 0000 on the bus after power-up, you press the RUN key to arm the state analyzer and then force a reset of your circuit. When the reset cycle ends, the microprocessor should send address 0000 trigger the state analyzer and switch the display to the State Listing menu.



From this point in the exercise unto the end, we will give you the measurement results. This way, you will not have to obtain and use an identical circuit.

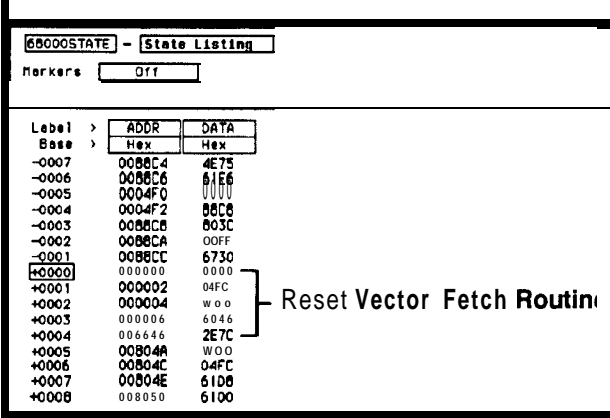

Label	ADDR		DATA	
	Hex	Hex	Hex	Hex
-0007	00B8C4		4E75	
-0006	00B8C6		51E6	
-0005	0004F0		0000	
-0004	0004F2		88C8	
-0003	00B8CB		803C	
-0002	00B8CA		00FF	
-0001	00B8CC		6730	
+0000	000000		0000	
+0001	000002		04FC	
+0002	000004		w o o	
+0003	000006		6046	
+0004	006446		2E7C	
+0005	00804A		w o o	
+0006	00804C		04FC	
+0007	00804E		6108	
+0008	008050		6100	

Figure 157. Reset Vector Fetch Routine

The State Listing

The state listing displays three columns of numbers as shown:

State Locations →

Label	ADDR	DATA
-0007	008C4	4E75
-0006	008C6	61E6
-0005	0004F0	0000
-0004	0004F2	88C0
-0003	008C8	8C3C
-0002	008CA	00FF
-0001	008CC	6730
+0000	00000	0400
+0001	00002	04FC
+0002	00004	0000
+0003	00006	8040
+0004	00040	2E7C
+0005	0080A	0000
+0006	0080C	04FC
+0007	0080E	6100
+0008	00800	6100

Figure 15-8. State Locations

The first column of numbers are the state line number locations as they relate to the trigger point. The trigger state is on line + 0000 in the vertical center of the list area. The negative numbers indicate states occurring before the trigger and the positive numbers indicate states occurring after the trigger.

The second column of numbers are the states (listed in HEX) the state analyzer sees on the address bus. This column is labeled ADDR.

The third column of numbers are the states (listed in HEX) the state analyzer sees on the data bus. This column is labeled DATA.

Finding the Answer

Your answer is now found in the listing of states + 0000 through + 0004.

The 68000 always reads address locations 0, 2, 4, and 6 to **find** the stack pointer location and memory location for the instruction it fetches after power-up. The 68000 uses two words for each of the locations that it is looking for, a high word and a low word. When the software designer programs the ROM, he must put the stack pointer location at address locations 0 and 2. 0 is the high word location and 2 is the low word location. Similarly, the high word of the instruction fetch location must be in address location 4 and the low word in location 6.

Since the software design calls for the reset vector to set the stack pointer to **04FC** and read memory address location 8048 for its first instruction fetch, you are interested in what is on both the address bus and the data bus in states 0 through 3.

The state listing below lists the codes reset vector search, in states 0 through 3 and the correct first microprocessor instruction in state 4.

```
+ 0000 000000 0000
+ 0001000002 04FC
+ 0002 000004 0000
+ 0003 000006 8048
+ 0004 008048 3E7C
```

You see that states 0 and 1 do contain address locations 0 and 2 under the ADDR label, indicating the microprocessor did look at the correct locations for the stack pointer data. You also see that the data contained in these ROM locations are 0000 and **04FC**, which are correct.

You then look at states 2 and 3. You see that the next two address locations are 4 and 6, which is correct, and the data found at these locations is 0000 and 8048, which is also correct.

So far you have verified that the microprocessor has correctly performed the reset vector search. The next thing you must verify is whether the microprocessor addresses the correct location in ROM that it was instructed to address in state 4 and whether the data is correct in this ROM location. From the listing on your machine, you see that the address in state 4 is **008048**, which is correct, but the instruction found in this location is **2E7C**, which is not correct. You have found your problem: incorrect data stored in ROM for the microprocessor's first instruction.

- + 0000 000000 0000 (high word of stack pointer location)
- + 0001 000002 04FC (low word of stack pointer location)
- + 0002 000004 0000 (high word of instruction fetch location)
- + 0003 000006 8048 (low word of **instuction** fetch location)
- + **0004 008048 2E7C (first microprocessor instruction)**

6800CSTATE - State Listing		
Markers: <input type="checkbox"/> Off		
Label	ADDR	DATA
Base	Hex	Hex
-0007	0088C4	4E75
-0006	0088C6	61E6
-0005	0004F0	0000
-0004	0004F2	88CA
-0003	0088CB	803C
-0002	0088CA	00FF
-0001	0088CC	6730
+0000	000000	0000
+0001	000002	04FC
+0002	000004	W 6 0
+0003	000006	8048
+0004	008048	2E7C ← Incorrect Data
+0005	00804A	0000
+0006	00804C	04FC
+0007	00804E	61D8
+0008	000050	61D0

Figure 15-9. Incorrect Data

Summary

You have just learned how to make a simple state measurement with the HP 1652B Logic Analyzer. You have:

- specified a state analyzer
- learned which probes to connect
- assigned pods **1, 2,** and 3
- assigned labels
- assigned bits
- specified the J clock
- specified a trigger condition
- acquired the data
- interpreted the state listing

You have seen how easy it is to use the state analyzer to capture the data on the address and data buses. You can use this same technique to capture and display related data on the microprocessor status control, and various strobe lines. You are not limited to using this technique on microprocessors. You can use this technique any time you need to capture data on multiple lines and need to sample the data relative to a system clock.

Chapter 21 shows you how to use the logic analyzer as an interactive timing and state analyzer. You **will** see a simple measurement that shows you both timing waveforms and state listings and how they are correlated.

If you have an HP **1653B**, you do not have enough channels to simultaneously capture all the data for a **68000**. But, since you probably aren't working with 16-bit microprocessors, this example is still valuable because it shows you how to make the same kind of measurement on an eight-bit microprocessor.

Index

A

absolute	18-9	Specifying Patterns	3-18
Accessing System Configuration Menu	4-2	Auto-Measure	
Accessories		+ Width and -Width	25-9
available	1-7	Fall Time	25-6
manuals	1-7	Measurement Example	25-4
supplied	1-5	Period and Frequency	25-8
Accessories for HP 1652B/53B	1-5	Preshoot and Overshoot	25-10
accumulate	19-6	Rise Time	25-5
acquisition		Top and Base Voltages	25-3
fields (state trace)	10-13	VP-P	25-7
acquisition modes		Auto-Measure Field	25-1
glitch	18-5	Auto-Trig Field	24-6
state	10-13	Autoload	5-6,6-1
timing	18-3	disable	5-6
transitional	18-4	enable	5-6
activity indicators	20-5	autoloading a file	6-13
alternate printers	7-2	Automatic Measurement Algorithms	B-1
armed by		Autoscale	23-19
BNC	24-4	Autoscale Field	4-5
Machine 1 or 2	24-4	Axes (State Chart)	
Run	24-4	Sealing the	13-2
state	10-13	Selecting the	13-1
timing	18-3		
Armed by Field	24-3		
ASCII	17-9		
Assignment/Specification Menus			
Assigning Pod Bits to Labels	3-17		
description	3-17		
Specifying Edges	3-19		

B

base	17-8, 18-6
ASCII	17-9
State Trace	10-22
baud rate	5-16
bit assignment	9-4, 17-4
branches	10-14
per level	10-15

Marker Measurements	25-12	State Chart	8-9 • 8-10
markers		State Compare	8-6
Pattern (state)	11-4	State Format	8-2
Pattern (timing)	19-5	State Listing	8-5
Statistics (state)	11-6	State Trace	8-3
Statistics (timing)	19-6	State Waveform	8-7 - 8-8
Time (state)	11-6	timing analyzer	16-1
Time (timing)	19-4	Tuning Format	16-2
Timing Waveforms menu	19-3	Timing Trace	16-3
X and O	20-10	Timing Waveform	16-4
Markers Field for Scope		Trigger Menu	22-3
Sample Period Display	25-14	Waveform Selection	22-5
Search	25-16	Waveforms Menu	22-4
Specify Search Markers	25-16	menus	
Statistics	25-23	Disk Operations	5-3,6-1
Time	25-14	I/O	5-1
X-O Pattern from start	25-22	I/O Port Configuration	5-12
master clock	9-10	Specify Symbols (state)	9-7, 9-12
measurement example		Specify Symbols (timing)	17-7
state analyzer	15-1	State Chart	13-1
timing analyzer	20-1	State Compare	12-1
timing/state analyzer	21-1	State Format Specification	9-1
measurements		State Listing	11-1
microprocessor	A-1	State Trace	10-1
memory		State Waveform	14-1
acquisition	18-4 - 18-5	State Waveforms	14-1
menu fields		Timing Format Specification	17-1
Specify Symbols (state)	9-13	Timing Trace Specification	18-1
Specify Symbols (timing)	17-8	Timing Waveforms	19-1
st/Div (states-per-division)	14-4	Microprocessor Specific	
State Format Specification	9-3	Measurements	A-1
State Listing menu	11-3	Microprocessors Supported	A-3
State Trace menu	10-2	mixed clocks	9-11
Timing Format Specification	17-3	Mixed Mode Displays	26-1
Timing Trace Specification	18-2	Arming the Scope	26-4
Timing Waveforms menu	19-3	Displaying Tuning Waveforms	26-5
Menu Keys	3-2	State/State	26-3
menu maps		State/Timing/Scope Mixed	
Channel Menu	22-2	Mode Display	26-8
Specify Markers	22-5	Time-Correlated Displays	26-9
state analyzer	8-1	Timing/Scope	26-4

Timing/State	26-2
Mixed Mode Field	26-1
Mode Field	24-2
Edge	24-4
Immediate	24-3

N

name	
label	9-4, 17-4
symbol	17-10
Name Field	4-3

O

0 to Trig(ger)	19-4
occurrence counter	10-9
Offset Field	23-3
Operating Characteristics	F-1
Operating System Disk	6-18
Duplicating the	6-18
Operating System-loading	D-9
Overlapping Timing Waveforms	21-14

P

Pack Disk	5-9,6-1
Packing a Disk	6-17
paper width	5-17
Setting the	7-6
parity	5-15
pattern	
recognizers	10-2
Pattern Fields (state)	10-24
patterns	10-23
Duration (present for)	18-9
fields	10-22

find	18-7
Pod Clock	9-9
Pod Fields	4-6
Pod Grounding	2-5
pod threshold	
ECL	17-6
TTL	17-6
user-defined	17-6
Pod Thresholds	2-8

pods	
clock	9-9
threshold	9-6, 17-6
Polarity (Pol)	9-4, 17-4
Pop-up Menus	3-9
Power Cord Configurations	D-4
preprocessors	A-2
Preset Field	23-5
prestore	10-21
print	
All	5-2, 7-7
Screen	5-2, 7-7
Starting the Printout	7-7
Print All	5-2, 7-7
Print Screen	5-2, 7-7
printer	5-16
printers	
alternate	7-2
Hooking Up	7-2
Other HP Printers	7-9
supported	7-1
Probe Cables	2-6
Probe Connecting	
Analyzer to Target System	2-8
Disconnecting Probes from Pods	2-11
Grabbers to Probes	2-12
Grabbers to Test Points	2-12
Labels to Pods, Probes, Cables	2-13
Pods to Probe Cables	2-10
Probe Cables to Analyzer	2-9
Probe Field	23-4
Probe Grounding	2-6

Probe Inputs for Scope	2-7
Probe Pod Assemblies	2-4
Probes	2-5
Probing Options	
General Purpose Probing	2-3
HP 10269C General Purpose	
Probe Interface	2-2
HP 10320C User-Definable	
Interface	2-1
Termination Adapter	2-3
Probing System for Analyzer	
description	2-4
Grabbers	2-6
Maximum Probe Input Voltage	2-8
Pod Grounding	2-5
Probe Cable	2-6
Probe Grounding	2-6
Probe Pod Assemblies	2-4
Probes	2-5
Signal Line Loading	2-8
Probing System for Scope	
Compensation Signal Outputs	2-7
description	2-7
External Trigger Inputs	2-7
Maximum Probe Input Voltage	2-8
Probe Inputs	2-7
protocol	5-14
Purge	5-10, 6-1
Purging a File	6-14

Q

Qualifer Field (state)	10-23
qualifier	10-2
branching	10-8
fields	10-22
storage	10-8

R

range	
recognizers	10-2
ranges	10-24
Rear-Panel Controls and Connectors	
External Trigger BNCs	3-6
Fan	3-7
HP-IB Interface Connector	3-7
Intensity Control	3-6
Line Power Module	3-6
Pod Cable Connectors	3-6
Probe Compensation Signal	3-7
RS-232C Interface Connector	3-6
Recommended Protocol (RS-232C)	7-6
Rename	5-9, 6-1
repetitive	
trace mode (state)	10-13
trace mode (timing)	18-3
Repetitive Run Mode	24-7
Replacing Waveforms (State)	14-3
Returning to system configuration	3-8
Roll Data	3-16
Roll Keys	3-4
RS-232C	
default configuration	7-6
printer cables	7-3
recommended protocol	7-6
setting for HP printers	7 - 5
setting for non-HP printers	7-5
Run Key	3-3
Run Mode Field	24-7
Repetitive Mode Run	24-7
Single Mode Run	24-7

S

sample period	19-3
Scope	
Introduction	22-1
Scope Field	25-1
Scope Menus Overview	22-6
Scope On/Off Field	4-5
Select Key	3-4
Selecting a Waveform (State)	142
Selecting an Address (HPIB)	5-13
Selecting Fields	3-9
Selecting Menus	3-7
Selecting Options	3-10
self test	5-18
Self Tests-powerup	E-1
sequence levels	10-6
Delete Level	10-7
Insert Level	10-7
Reading the Display	10-11
Signal Line Loading	2-8
single	
trace mode (state)	10-13
trace mode (timing)	18-3
Single Run Mode	247
slave clock	9-10
Slope Field	246
Source Field	244
Specifications	F-1
Specify Search Markers	
Greater than	25-20
In/Not IN Range	25-21
Less than	25-19
Type	25-17
X-O Marker set on	25-17
Specifying Edges	3-19
Specifying Patterns	3-18
st/Div (states-per-division)	14-1, 14-4
state analyzer	8-1

An Overview	8-1
menu maps	8-1
State Chart menu	13-1
Accessing the	13-1
state clock	9-7
State Compare menu	
Accessing the	12-2
State Format Specification menu	9-1
Accessing the	9-1
fields	9-3
State Listing menu	11-1
Accessing the	11-2
fields	11-3
state tagging	10-20
State Trace menu	10-1
Accessing the	10-2
fields	10-2
State Waveforms menu	14-1
Accessing the	14-1
State/State Mixed Mode Display	26-3
Statistics	25-23
Stop bits	5-15
Stop Key	3-3
Stop Measurement	
state	11-5
Stop Measurement (timing)	19-5
storage macro	10-9
storage qualifier	10-8
Store	5-5, 6-1
Store exception to disk	
state	11-5
State Compare	12-7
timing	19-6
Storing to a Disk	6-9
supported printers	7-1
Switching Between Analyzer	
and Scope	3-8
symbols	17-7
base	9-14, 17-8
label	9-13, 17-8
name	9-15, 17-10

Toggle Fields	3-11
User-Definable Interface	2-1

V

V/Div Field	23-2
view size	
symbol	17-10

W

Waveform Selection	23-6
Insert/Delete	23-9
Math	23-12
Modify	23-10
Overlay	23-11
Turning them ON/OFF	23-8
Waveforms Menu	
Auto-Measure Field	25-1
Connect dots Field	25-31
Description	25-1
Display Field	25-29
Marker Measurements	25-12
Markers Field	25-13
Scope Field	25-1
Search Marker Measurement	
Example	25-24

X

X and O markers	
State Chart	13-5
State Waveform	14-5
Timing Waveforms	20-10
X to Trig(ger)	19-4

1mk+

Front-Panel Operation Reference

Volume 2 of 2

HP 1652B/HP 1653B Logic Analyzers



@Copyright Hewlett-Packard Company 1989

Manual Set Part Number 01652-90902

Printed in the U.S.A. November 1989

Contents Volume 2

Chapter 16:	The Timing Analyzer	
	Introduction16-1
	The Timing Analyzer (An Overview)16-1
	Timing Analyzer Menu Maps16-1
	Timing Format Menu Map16-2
	Timing Trace Menu Map16- 3
	Timing Waveform Menu Map16- 4
Chapter 17:	Timing Format Specification Menu	
	Introduction17- 1
	Accessing the Timing Format Specification Menu17-1
	Timing Format Specification Menu17-1
	Timing Format Specification Menu Fields17-3
	Label17-3
	Turn Label On17-3
	Modify Label17-4
	Turn Label Off.17-4
	Polarity (Pol)17-4
	Bit Assignment17-4
	Pod Threshold17-6
	Specify Symbols Menu17-7
	Specify Symbols Menu Fields17-8
	Label17-8
	Base17- 8
	Symbol View Size17-10
	Symbol Name17-10
	Leaving the Symbol Table Menu17-12
Chapter 18:	Timing Trace Specification Menu	
	Introduction18-1
	Accessing the Timing Trace Specification Menu18-1
	Timing Trace Specification Menu18-1
	Timing Trace Specification Menu Fields18-2
	Trace Mode18- 3
	Armed By18-3

Acquisition Mode	18-3
Transitional Acquisition Mode	18-4
Glitch Acquisition Mode	18-5
Label	18-6
Base	18-6
Find Pattern	18-7
Pattern Duration (present for)	18-9
Then Find Edge	18-11

Chapter 19:

Timing Waveforms Menu

Introduction	19-1
Accessing the Timing Waveforms Menu	19-2
Timing Waveforms Menu Fields	19-3
Markers	19-3
Markers Time	19-4
Markers Patterns	19-5
Stop Measurement	19-5
Markers Statistics	19-6
Accumulate Mode	19-6
At Marker	19-7
Time/Div (time per division) Field	19-8
Delay Field	19-9

Chapter 20:

Timing Analyzer Measurement Example

Introduction	20-1
Problem Solving with the Timing Analyzer	20-2
What Am I Going to Measure?	20-2
How Do I Configure the Logic Analyzer?	20-3
Connecting the Probes	20-5
Activity Indicators	20-5
Configuring the Timing Analyzer	20-6
Specifying a Trigger Condition	20-8
Acquiring the Data	20-9
The Timing Waveforms Menu	20-10
The X and O	20-10
The ▼	20-11
The Vertical Dotted Line	20-11
Configuring the Display	20-12
Display Resolution	20-12

Making the Measurement20-13
Finding the Answer20-14
Summary20-15

Chapter 21:

Timing/State Measurement Example

Introduction21- 1
Problem Solving with the Timing/State Analyzer21-2
What Am I Going to Measure?21-2
How Do I Configure the Logic Analyzer?21-3
Configuring the State Analyzer21-4
Connecting the Probes21-5
Acquiring the Data21-5
Finding the Problem21-6
What Additional Measurements Must I Make?21-7
How Do I Re-configure the Logic Analyzer?21-8
Connecting the Timing Analyzer Probes21-8
Configuring the Timing Analyzer21-9
Setting the Timing Analyzer Trigger21-10
Time Correlating the Data21-11
Re-acquiring the Data.....	.21-12
Mixed Mode Display21-12
Interpreting the Display21-13
Overlapping Timing Waveforms21-14
Finding the Answer21-15
Summary21-16

Chapter 22:

The Oscilloscope

Introduction22-1
The Scope (An Overview)22-1
Scope Menu Maps22-1
The Channel Menu Map22-2
The Trigger Menu Map22-3
The Waveforms Menu Map22- 4
Waveform Selection Menu Map22-5
Specify Markers Menu Map22-5
Menu Overview22- 6

Chapter 23:**Channel Menu**

Introduction	23-1
Channel Menu Fields	23-1
Input Field	23-1
V/Div Field	23-2
Offset Field	23-3
Probe Field	23-4
Impedance Field	23-5
Preset Field	23-5
Waveform Selection	23-6
Waveform Selection Setup	23-7
Connecting the Equipment	23-7
Setting Up the Oscilloscope	23-7
Turning the Waveforms On/Off	23-8
Insert/Delete Waveforms	23-9
Modify Waveforms	23-10
Overlay (C1,C2)	33-11
Waveform Math (C1 + C2), (C1-C2)	33-12
Timebase Functions	33-13
Instrument Setup	23-13
s/Div Field	23-14
Zoom (Acquisition Stopped)	23-15
Zoom Example	23-15
Delay Field	33-17
Scrolling (Acquisition Stopped)	33-17
Scroll Example	23-18
Autoscale Field	23-19
When a Signal is Found	23-20
If No Signal is Found	23-21

Chapter 24:**Trigger Menu**

Introduction	24-1
Calibration	24-1
Trigger Marker	24-2
Mode Field	24-2
Immediate Trigger Mode	24-3
Armed by Field	24-3
Run	24-4

BNC Input	24-4
Machine 1 and 2	24-4
Edge Trigger Mode	24-4
Source Field
Level Field	24-5
Slope Field	24-6
Auto-Trig Field	24-6
On	6
Off..	6
Run mode Field	24-7
Single Mode Run	24-7
Repetitive Mode Run	24-7

Chapter 25:

Waveforms Menu

Introduction	25-1
Scope Field	25-1
Auto-MeasureField	25- 1
Top and Base Voltages	25-3
Automatic Measurement Example	25-4
Connecting the Equipment	25-4
Setting Up the Oscilloscope	25-4
Rise Time Measurement	25-5
Fall Time Measurement	25-6
Vp-p Measurement	25- 7
Period and Frequency Measurements	25-8
+ Width and -Width Measurements	25-9
Preshoot and Overshoot Measurements	25-10
Marker Measurements	25-12
Markers Field	25-13
Sample Period Display	25-14
Time..	25-14
X to 0 Field	25-14
Trig to X Field	25-15
Trig to O Field	25-15
Search	25-16
Specify Search Markers	25-16
Typemarkers	25-17
X-Marker set on ___& O-Marker set on___	25-17
Stop Measurement when X-O	25-18
Less than	25-19

Greaterthan..	25-20
Inrange... to__	25-21
Not in range- to__	25-21
Store exception to disk:	25-22
X-pattern -from start &O-pattern- from start	25-22
Statistics..	25-23
Search Marker Measurement Example	25-24
Connecting the Equipment	25-24
Making the Measurement	25-24
Display Field	25-29
Normal Mode	25-29
Average Mode	25-30
Accumulate Mode	25-31
Connect Dots Field	25-31
Grid..	25-31

Chapter 26:

Mixed Mode Displays

Introduction	..26- 1
Mixed Mode field	..26- 1
Timing/State Mixed Mode Display	..26-2
State/State Mixed Mode Display	..26-3
Timing/Scope Mixed Mode Display	..26-4
Arming the Oscilloscope	..26-4
Displaying Timing Waveforms	..26-5
State/Timing And Scope Mixed Mode Display	..26-8
Time-Correlated Displays	..26-9

Chapter 27:

Timing/State/Oscilloscope Measurement Example

Introduction	..27- 1
Problem Solving with the Timing/State/Scope Analyzer	..27-1
What Am I Going to Measure?	..27-2
How Do I Configure the Logic Analyzer?	..27-3
Configuring the State Analyzer	..27-4
Connecting the Probes	..27-6
Acquiring the Data	..27-6
Finding the Problem	..27-7
What Additional Measurements Must I Make?	..27-8
How Do I Re-configure the Logic Analyzer?	..27-9
Connecting the Timing Analyzer Probes	..27-9

Configuring the Timing Analyzer	27-10
Setting the Timing Analyzer Trigger	27-11
Time Correlating the Data	27-12
Re-acquiring the Data	27-13
Mixed Mode Display	27-13
Interpreting the Display	27-14
Re-configure the Analyzer with Scope	27-14
Connecting the Scope Probes	27-15
Arming the Scope	27-16
Making the Scope Measurement	27-17
Mixed Mode Display with Scope	27-18
Finding the Answer	27-19
Summary	27-19

Appendix A:

Microprocessor Specific Measurements

Introduction	A-1
Microprocessor Measurements	A-1
Microprocessors Supported by Preprocessors	A-2
Z80	A-3
NSC 800	A-4
8085	A-5
8086 or 8088	A-6
80186 or 80C186	A-7
80286	A-8
80386	A-9
6800 or 6802	A-10
6809 or 6809E	A-11
68008	A-12
68000 and 68010 (64-pin DIP)	A-13
68000 and 68010 (68-pin PGA)	A-14
68020	A-15
68030	A-16
68HC11	A-17
Loading Inverse Assembler Files	A-18
Selecting the Correct File	A-18
Loading the Desired File	A-18
Connecting the Logic Analyzer Probes	A-19
How to Display Inverse Assembled Data	A-19

Appendix B:**Automatic Measurement Algorithms**

Introduction	B-1
Measurement Setup	B-1
Making Measurements	B-1
Top and Base Voltages	B-2
Measurement Algorithms	B-3
Frequency(Freq)	B-3
Period	B-3
Peak-to-Peak Voltage (Vp_p)	B-3
Positive Pulse width (+ Width)	B-4
Negative Pulse width (-Width)	B-4
Risetime..	B-4
Falltime	B-4
Preshoot and Overshoot	B-5
Duty Cycle	B-6
rms Voltage	B-6
Average Voltage	B-6

Appendix C:**Error Messages**

Introduction	C-1
--------------------	------------

Appendix D:**Installation, Maintenance and Calibration**

IntroductionD- 1
Initial InspectionD- 1
Operating Environment	D-2
Ventilation..D- 2
Storage and Shipping	D-2
Tagging for Service	D-2
Original Packaging	D-2
Other Packaging	D-3
Power Requirements	D-3
Power Cable	D-4
Removing Yellow Shipping Disc	D-6
Selecting the Line Voltage	D-7
Checking for the Correct Fuse	D-8
Applying Power	D-8
Loading the Operating System	D-8

Installing the Operating System Disc	D-9
Line SwitchD-10
Intensity Control	D-10
Operator's Maintenance	D-11
CalibrationD-11
Calibration Interval	D-11
Calibration Integrity	D-11
Software Calibration Procedures	D-12
Offset Calibration	D-12
Attenuator Calibration	D-13
Gain CalibrationD-14
Trigger Calibration	D-14
Delay Calibration	D-15

Appendix E:

Operator Self Tests

Introduction	E-1
Self Tests	E-1
Power-up Self Test	E-1
Selectable Self Tests	E-2

Appendix F:

Specifications and Operating Characteristics

Introduction	F-1
Logic Analyzer Specifications	F-1
Probes	F-1
State Mode	F-1
Timing Mode	F-2
Logic Analyzer Operating Characteristics	F-2
Probes	F-2
Measurement Configurations	F-3
State Analysis	F-3
Memory	F-3
Trace Specification	F-3
Tagging..	F-4
Symbols..	F-5
State Compare Mode	F-5
State X-T Chart	F-6
State Waveform	F-6
Timing Analysis	F-7
Transitional Timing Mode	F-7

Glitch Capture Mode	F-7
Waveform Display	F-7
Time Interval Accuracy	F-8
Trigger Specification	F-8
Measurement and Display Functions	F-8
Autoscale (Timing Analyzer Only)	F-8
Acquisition Specifications	F-8
Labels	F-9
Indicators	F-9
Marker Functions	F-9
Run/Stop Functions	F-10
Data Display/Entry	F-10
Oscilloscope Specifications	F-11
Vertical (at BNC)	F-11
Horizontal	F-11
Trigger	F-11
Oscilloscope Operating Characteristics	F-11
Vertical	F-11
Horizontal	F-13
Trigger	F-13
Waveform Display	F-14
Measurement Aids	F-15
Setup Aids	F-15
Interactive Measurements	F-16
Acquisition	F-16
Mixed Display	F-16
Time Correlation	F-16
Time Interval Accuracy Between Modules	F-16
General Characteristics	F-17
Operating Environment	F-17
Power Requirements	F-18
Weight	F-18
Dimensions	F-18

Index

The Timing Analyzer

Introduction

This chapter introduces the timing analyzer and contains the timing analyzer menu maps.

Chapters 17 through 19 explain each of the Timing Analyzer menus as follows:

- Chapter 17 explains the Timing Format Menu.
- Chapter 18 explains the Timing Trace Menu.
- Chapter 19 explains the Timing Waveforms Menu.
- Chapter 20 gives you a basic Timing Analyzer Measurement example.
- Chapter 21 gives you a basic Timing/State Analyzer Measurement example.

The Timing Analyzer (An Overview)

The timing analyzer acquires data asynchronously using an internal sample clock. This asynchronous data acquisition technique is similar to a digitizing oscilloscope. The acquired data is displayed in the form of one or more waveforms. The timing waveforms **differ** from a digitizing oscilloscope in that the timing analyzer only stores and displays two levels (one above and one below threshold).

Timing Analyzer Menu Maps

The Timing Analyzer menu maps show you the fields and the available options of each **field** within the three menus. The menu maps will help you get an overview of each menu as well as provide you with a quick reference of what each menu contains.

Timing Format Menu Map

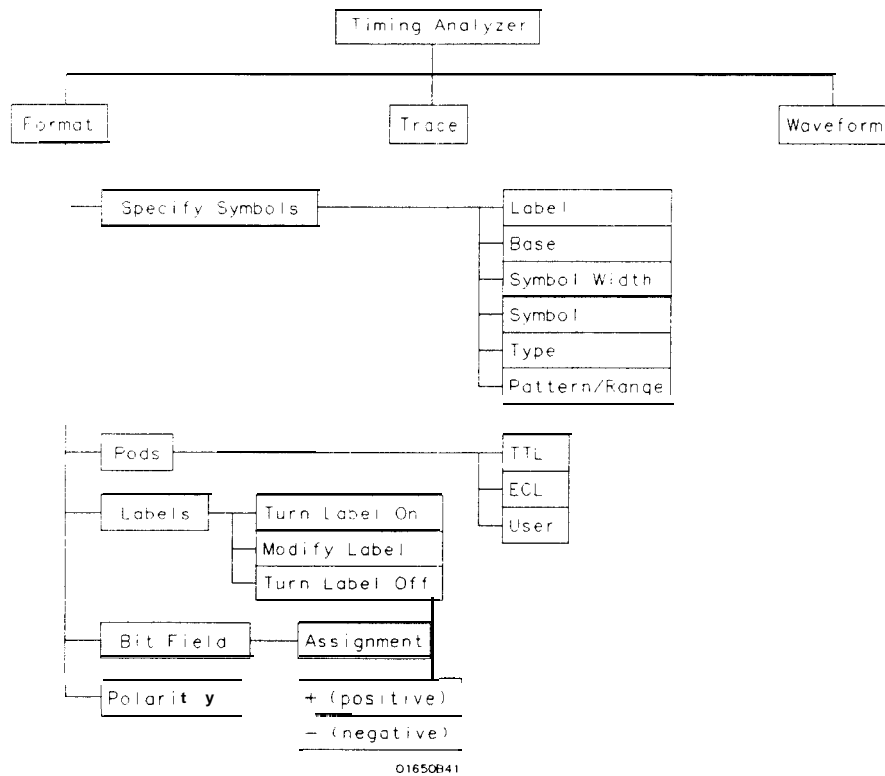
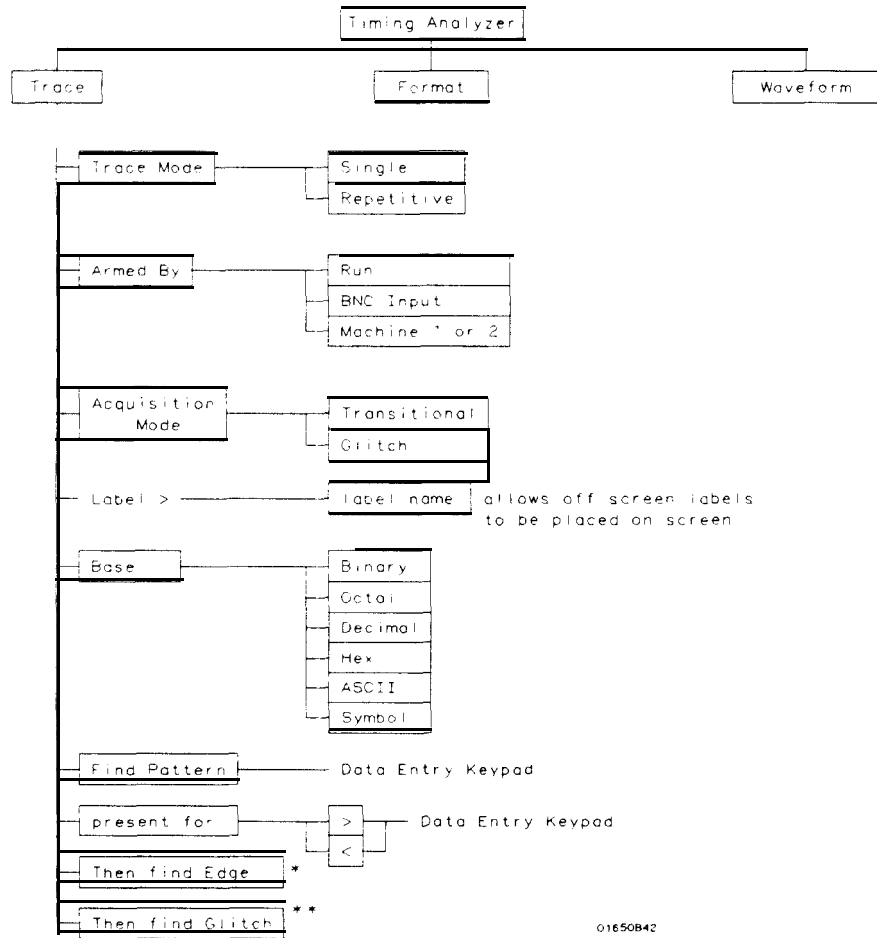

Figure 16-1. Timing Format Menu Map

Timing Trace Menu Map



01650B42

- * Only available when "greater than" is specified in "present for" field
- ** Only available when "then find edge" is present and in Glitch mode

Figure 16-2. Timing Trace Menu Map

Timing Waveform Menu Map

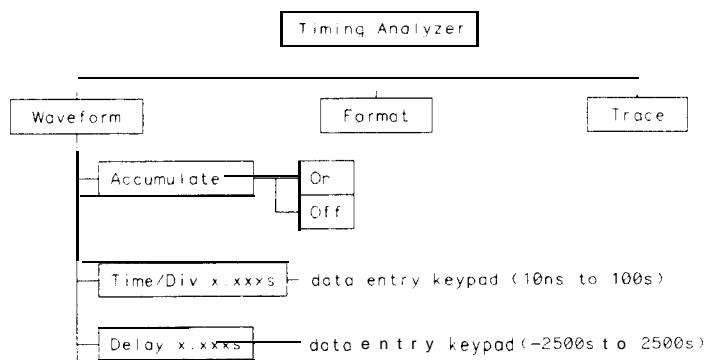

Continued on next page

01650B43

Figure 163. Timing Waveform Menu Map

Continued from previous page

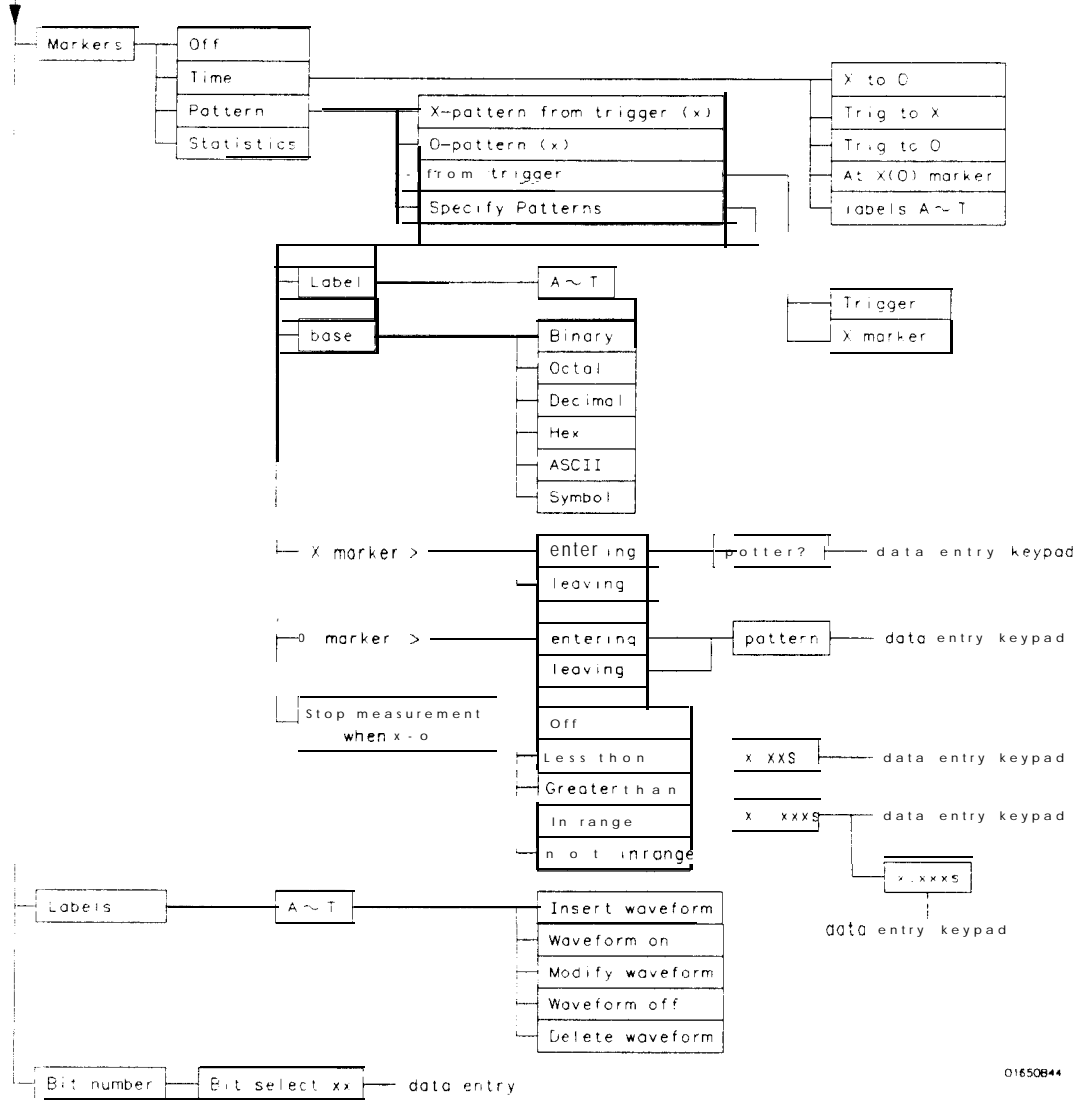

01650B44

Figure 8-3. Timing Waveform Menu Map (Continued)

Timing Format Specification Menu

Introduction

This chapter describes the Timing Format Specification menu and all the pop-up menus that you will use on your timing analyzer. The purpose and function of each pop-up menu is explained in detail, and we have included many illustrations and examples to make the explanations clearer.

Accessing the Timing Format Specification Menu

The Timing Format Specification menu can be accessed by pressing the FORMAT key on the front panel. If the State Format Specification Menu is displayed when you press the FORMAT key, you will have to switch analyzers. This is not a problem, it merely indicates that the last action you performed in the System Configuration Menu was on the state analyzer.

Timing Format Specification Menu

The Timing Format Specification menu lets you configure the timing analyzer to group channels from your microprocessor into labels you assign for your measurements. You can set the threshold levels of the pods assigned to the analyzer, assign labels and channels, and specify symbols.

At power up, the logic analyzer is configured with a default setting. You can use this default setting to make a test measurement on the system under test. It can give you an idea of where to start your measurement. For an example of setting up configurations for the Timing analyzer, refer to the *Getting Starred Guide* or “Timing Analyzer Measurement Example” in chapter 20 of this manual.

At power up the Timing Format Specification menu looks like that shown below:

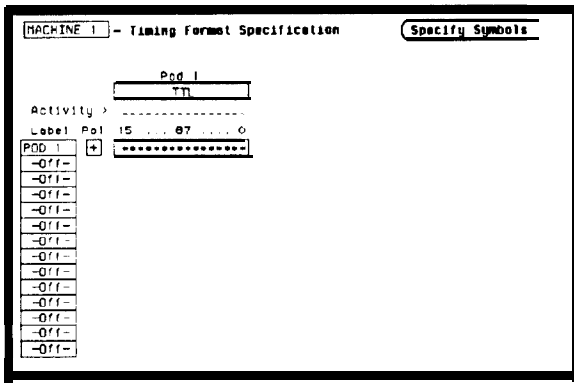

Figure 17-1. Timing Format Specification Menu

The Timing Format Specification menu for the HP 1653B is similar to that for the HP 1652B except that Pod 2 appears in the menu instead of Pod 5.

This menu shows only one pod assigned to each analyzer, which is the case at power up. Any number of pods can be assigned to one analyzer, from none to all five for the HP 1652B, and from none to two for the HP 1653B. In the Timing Format Specification menu, only three pods appear at a time in the display. To view any pods that are off screen, press the left/right ROLL key and rotate the KNOB. The pods are always positioned so that the lowest numbered pod is on the right and the highest numbered pod is on the left.

Timing Format Specification Menu Fields

Five types of fields present in the menu are as follows:

- Label.
- Polarity (Pol).
- Bit assignments.
- Pod threshold.
- Specify Symbols.

A portion of the menu that is not a **field** is the Activity Indicators display. The indicators appear under the active bits of each pod, next to “Activity.” When the logic analyzer is connected to your target system and the system is running, you will see **I** in the Activity Indicators display for each channel that has activity. These tell you that the signals on the channels are transitioning.

The fields in the Format menus are described in this following sections.

Label

The label column contains 20 Label fields that you can define. Of the 20 labels, the logic analyzer displays only 14 in the Timing Format Specification menu at one time. To view the labels that are off screen, press the up/down ROLL key and rotate the KNOB. The labels scroll up and down. To deactivate the scrolling, press the ROLL key again,

To access one of the Label fields, place the cursor on the field and press SELECT. You will see a pop-up menu like that shown below.

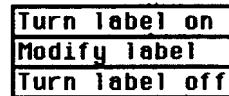

Figure 17-2. Label Pop-Up Menu

Turn Label On

Selecting this option turns the label on and gives it a default letter name. If you turned all the labels on they would be named A through T from top to bottom. When a label is turned on, the bit assignment fields for that label, appear to the right of the label.

Modify Label

If you want to change the name of a label, or want to turn a label on and give it a specific name, you would select the **Modify** label option. When you do, an Alpha Entry pop-up menu appears. You can use the pop-up menu and the keypad on the front panel to name the label. A label name can be a maximum of six characters.

Turn Label Off

Selecting this option turns the label off. When a label is turned off, the bit assignments are saved by the logic analyzer. This gives you the option of turning the label back on and still having the bit assignments if you need them. The waveforms are also saved.

You can give the same name to a label in the state analyzer as in the timing analyzer without causing an error. The logic analyzer distinguishes between them. An example of this appears in “Using the Timing/State Analyzer” in chapter 7 of the **Getting Started Guide**.

Polarity (Pol)

Each label has a polarity assigned to it. The default for all the labels is positive (+) polarity. You can change the polarity of a label by placing the cursor on the polarity field and pressing SELECT. This toggles the polarity between positive (+) and negative (-).

In the timing analyzer, negative polarity inverts the data.

Bit Assignment

The bit assignment fields allow you to assign bits (channels) to labels. Above each column of bit assignment fields is a line that tells you the bit numbers from 0 to 15, with the left bit numbered 15 and the right bit numbered 0. This line helps you know exactly which bits you are assigning.

The convention for bit assignment is:

- * (asterisk) indicates assigned bit
- . (period) indicates unassigned bit

At power up **the** 16 bits of Pod 1 are assigned to the timing analyzer and the 16 bits of Pod 5 are assigned to the state analyzer. To change a bit assignment configuration, place the cursor on a bit assignment field and press SELECT. You will see the following pop-up menu.

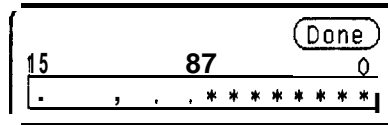

Figure 17-3. Bit Assignment Pop-Up Menu

Use the KNOB to move the cursor to an asterisk or a period and press SELECT. The bit assignment toggles to the opposite state of what it was before. When the bits (channels) are assigned as desired place the cursor on Done and press SELECT. This closes the pop-up and displays the new bit assignment.

Assigning one channel per label may be handy in some applications. This is illustrated in “Using the Timing/State Analyzer” in chapter 7 of the *Getting Started Guide* and chapter 21 of this manual. In addition, you can assign a channel to more than one label.

Labels may have from 1 to 32 channels assigned to them. If you try to assign more than 32 channels to a label, the logic analyzer will beep, indicating an error, and a message will appear at the top of the screen telling you that 32 channels per label is the maximum.

Channels assigned to a label are numbered from right to left by the logic analyzer. The least significant assigned bit (LSB) on the far right is numbered 0, the next assigned bit is numbered 1, and so on. Since 32 channels can be assigned to one label at most, the highest number that can be given to a channel is 31. Although labels can contain split fields, assigned channels are always numbered consecutively within a label as shown in figure 17-4.

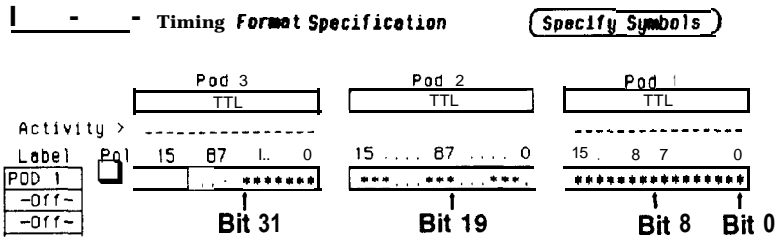

Figure 17-4. Numbering of Assigned Bits

Pod Threshold

Each pod has a threshold level assigned to it. For the HP 1653B Logic Analyzer, threshold levels may be defined for Pods 1 and 2 individually. For the HP 1652B Logic Analyzer, threshold levels may be defined for Pods 1, 2 and 3 individually, and one threshold for Pods 4 and 5. It does not matter if Pods 4 and 5 are assigned to different analyzers. Changing the threshold of one will change the threshold of the other.

If you place the cursor on one of the pod threshold fields and press SELECT, you will see the following pop-up menu.

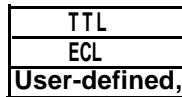

Figure 17-5. Pod Threshold Pop-Up Menu

TTL sets the threshold at + 1.6 volts, and ECL sets the threshold at - 1.3 volts.

The User-defined option lets you set the threshold to a specific voltage between -9.9 V and + 9.9 V. If you select this option you will see a Numeric Entry pop-up menu as shown.

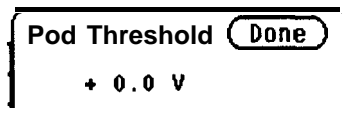

Figure 17-6. User-Defined Numeric Entry Pop-Up Menu

You can change the value in the pop-up either with the keypad on the front panel or with the KNOB, which you rotate until you get the desired voltage. When the correct voltage is displayed, press SELECT. The pop-up will close and your new threshold will be placed in the pod threshold field.

Specify Symbols Menu

The **Specify Symbols** field differs from the other fields in the Timing Format Specification menu in that it displays a complete menu instead of a pop-up.

The logic analyzer supplies Timing and State Symbol Tables in which you can define a mnemonic for a specific bit pattern of a label. When measurements are made by the timing analyzer, the mnemonic is displayed where the bit pattern occurs if the Symbol base is selected.

It is possible for you to specify up to 200 symbols in the logic analyzer. If you have only one of the internal analyzers on, all 200 symbols can be defined in it. If both analyzers are on, the 200 symbols are split between the two. For example, analyzer 1 may have 150, leaving 50 available for analyzer 2.

To access the Symbol Table in the Timing Format Specification menu, place the cursor on the **Specify Symbols** field and press SELECT. You will see a new menu as shown in figure 17-7. This is the default setting for the Symbol Table in both the timing and state analyzers.

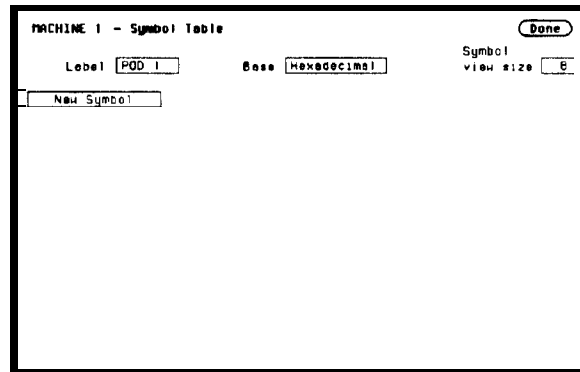

Figure 17-7. Symbol Table Menu

Specify Symbols Menu Fields

There are four fields in the Symbol Table menu. They are:

- Label
- Base
- Symbol view size
- Symbol name

Label The Label field identifies the label for which you are specifying symbols. If you select this field, you will get a pop-up that lists all the labels turned on for that analyzer.

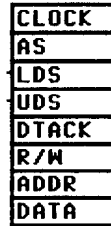

Figure 17-8. Label Pop-Up Menu

Each label has a separate symbol table. This allows you to give the same name to symbols defined under different labels. In the Label pop-up select the label for which you wish to specify symbols.

Base The Base field tells you the numeric base in which the pattern will be specified. The base you choose here **will** affect the **Find Pattern** field of the Timing Trace Specification menu. This is covered later in this chapter.

To change the base, place the cursor on the Base field and press SELECT. You will see the following pop-up menu.

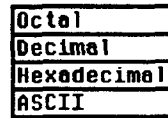



Figure 17-9. Base Pop-Up Menu

If more than 20 channels are assigned to a label, the Binary option is not offered in the pop-up. The reason for this is that when a symbol is specified as a range, there is only enough room for 20 bits to be displayed on the screen.

Decide which base you want to work in and choose that option from the numeric Base pop-up menu.

If you choose the ASCII option, you can see what ASCII characters the patterns and ranges defined by your symbols represent. ASCII characters represented by the decimal numbers 0 to 127 (hex 00 to 7F) are offered on your logic analyzer. Specifying patterns and ranges for symbols is discussed in the next section.

Note  You cannot specify a pattern or range when the base is ASCII. First define the pattern or range in one of the other bases, then switch to ASCII to see the ASCII characters.

Symbol View Size The Symbol view size field lets you specify how many characters of the symbol name will be displayed when the symbol is referenced in the Timing Trace Specification menu and the Timing Waveforms menu. Selecting this field gives you the following pop-up.

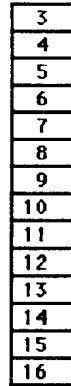

3
4
5
6
7
8
9
10
11
12
13
14
15
16

Figure 17-10. Symbol View Size Pop-Up Menu

You can have the logic analyzer display from 3 to all **16** of the characters in the symbol name. For more information see “Timing Trace Specification Menu” in Chapter 18 and the “Timing Waveforms Menu” in Chapter 19.

Symbol Name When you first access the Symbol Table, there are no symbols specified. The symbol name field reads “New Symbol.” If you select this field, you will see an Alpha Entry pop-up menu on the display. Use the pop-up menu and the keypad on the front panel to enter the name of your symbol. A maximum of 16 characters can be used in a symbol name. When you select the Done field in the Alpha Entry pop-up menu the name that appears in the symbol name field is assigned and two more fields appear in the display.

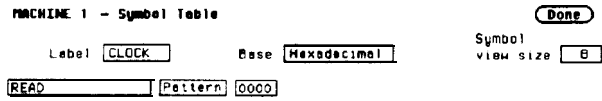

Figure 17-1. Symbol Defined as a Pattern

The first of these fields defines the symbol as either a Pattern or a Range. If you place the cursor on this field and press SELECT, it will toggle between Pattern and Range.

When the symbol is defined as a pattern, one field appears to specify what the pattern is. Selecting this field gives you a pop-up with which you can specify the pattern. Use the keypad and the DON'T CARE key on the front panel to enter the pattern. Be sure to enter the pattern in the numeric base that you specified in the **Base** field.

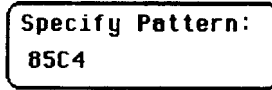

Figure 17-12. Specify Pattern Pop-Up

If the symbol is defined as a range, two fields appear in which you specify the upper and lower boundaries of the range.

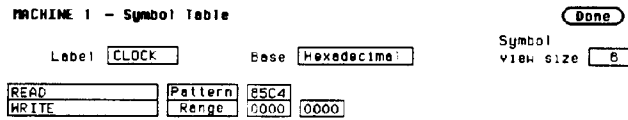

Figure 17-13. Symbol Defined as a Range

Selecting either of these fields gives you a pop-up with which you can specify the boundary of the range.

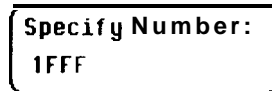

Figure 17-14. Specify Range Pop-Up

You can specify ranges that overlap or are nested within each other. Don't cares are not allowed.

To add more symbols to your symbol table, place the cursor on the last symbol defined and press SELECT. A pop-up menu appears as shown.

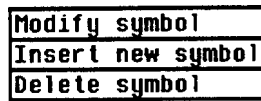

Figure 17-15. Symbol Pop-Up Menu

The first option in the pop-up is Modify symbol. If you select this option, you will see an Alpha Entry pop-up menu with which you can change the name of the symbol.

The second option in the pop-up is Insert new symbol. It allows you to specify another symbol. When you select it, you will see an Alpha Entry pop-up menu. Use the menu and the keypad on the front panel to enter the name of your new symbol. When you select Done, your new symbol will appear in the Symbol Table. The third option in the pop-up is Delete symbol. If you select this option, the symbol will be deleted from the Symbol Table.

Leaving the Symbol Table Menu

When you have specified all your symbols, you can leave the Symbol Table menu in one of two ways. One method is to place the cursor on the Done field and press SELECT. This puts you back in the Format Specification menu that you were in before entering the Symbol Table. The other method is to press the FORMAT, TRACE, or DISPLAY keys on the front panel to get you into the respective menu.

Timing Trace Specification Menu

Introduction

This chapter describes Timing Trace Specification menu and all the pop-up menus that you will use on your timing analyzer. The purpose and function of each pop-up menu is explained in detail, and we have included many illustrations and examples to make the explanations clearer.

Accessing the Timing Trace Specification Menu

The Timing Trace Specification menu can be accessed by pressing the TRACE key on the front panel. If the State Trace Specification menu is displayed when you press the TRACE key, you will have to switch analyzers. This is not a problem, it merely indicates that the last action you performed in the System Configuration Menu was on the state analyzer.

Timing Trace Specification Menu

The Trace Specification menus allow you to configure the logic analyzer to capture only the data of interest in your measurement. In the timing analyzer you can configure the analyzer to trigger on specific patterns, edges, or glitches. The Timing Trace Specification menu lets you specify the trigger point for the logic analyzer to start capturing data and the manner in which the analyzer will capture data. You configure the timing analyzer to find a pattern first and then a transition in the signal or signals.

At power up, the logic analyzer is configured with a default setting. You can use this default setting to make a test measurement on the system under test. It can give you an idea of where to start your measurement. For an example on setting up configurations for the Timing analyzer, refer to the Getting *Started* Guide or “Timing Analyzer Measurement Example” in Chapter 20 of this manual.

At power up the Timing Trace menu looks like that shown below.

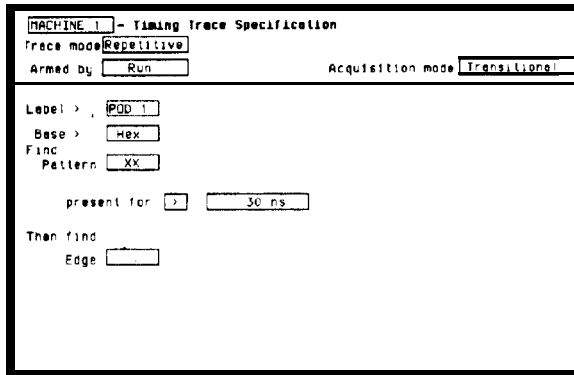

Figure 18-1. Timing Trace Specification Menu

The menu is divided into two sections by a horizontal line. The top section contains the fields that you use to specify the data acquisition. The bottom section contains the fields for setting the trigger point.

Timing Trace Specification Menu Fields

The fields in the Timing Trace Specification menu are as follows:

- Trace mode.
- Armed by.
- Acquisition mode.
- Label.
- Base.
- Find Pattern.
- Pattern Duration (present for ____).
- Then **find** Edge.

These fields are described in this chapter.

Trace Mode With the Trace **mode** field you specify the mode in which the timing analyzer will trace. You have two choices for Trace mode: Single and Repetitive. If you place the cursor on the field and press SELECT, the **field** toggles from one mode to the other.

Single Trace mode acquires data once per trace. Repetitive Trace mode repeats single acquisitions until the STOP key on the front panel is pressed, or if Stop measurement has been selected and the stop measurement condition has been met.

If both analyzers are on, only one Trace mode can be specified. Specifying one trace mode for one analyzer sets the same trace mode for the other analyzer.

Armed By The Armed **by** field lets you specify how your timing analyzer is to be armed. The analyzer can be armed by the RUN key, the other analyzer, the scope or an external instrument through the BNC Input port.

When you select the **Armed by** field, a pop-up menu appears like that shown below. Use this menu to select the arming option for your analyzer.

Armed by

Run
BNC Input
Machine 1
Scope

Figure18-2. Armed By Pop-Up Menu

Acquisition Mode The **Acquisition mode** field allows you to specify the mode in which you want the timing analyzer to acquire data. You are given two choices for the mode of acquisition: Transitional and Glitch. If you place the cursor on this field and press SELECT, the field toggles from one mode to the other.

Transitional Acquisition Mode

When the logic analyzer is operating in the Transitional Acquisition mode, it samples the data at regular intervals, but it stores data in memory only on transitions in the signals. A time tag that is stored with each sample allows reconstruction of the samples in the Timing Waveforms display.

Transitional timing always samples at a rate of 100 MHz (10 ns/sample). This provides maximum timing resolution even in records that span long time windows. Time covered by a full memory acquisition varies with the number of pattern changes in the data. If there are many transitions, the data may end prior to the time window desired because the memory is full. However, a prestore qualification in your logic analyzer insures that data will be captured and displayed between the left side of the screen and the trigger point.

Figure 18-3 illustrates Transitional acquisition, comparing it to Traditional acquisition.

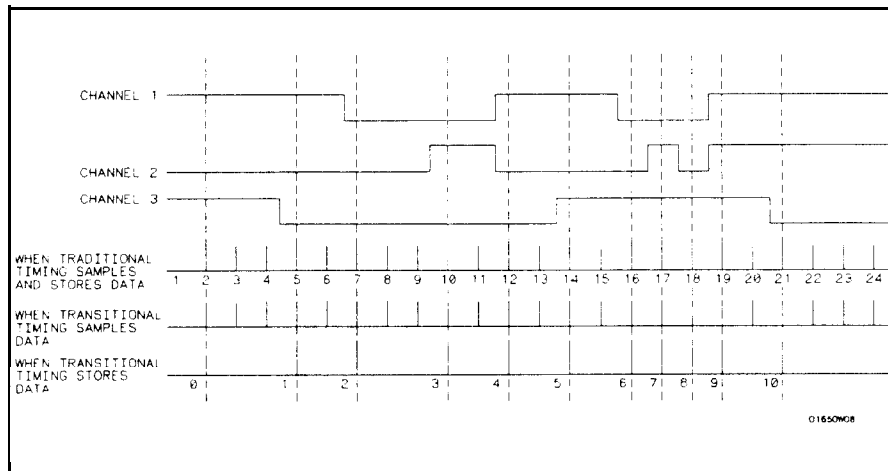

Figure 18-3. Transitional vs. Traditional Acquisition

Traditional timing samples and stores data at regular intervals. Transitional timing samples data at regular intervals but stores a sample only when there has been a transition on one or more of the channels. This makes it possible for Transitional timing to store more information in the same amount of memory.

Glitch Acquisition Mode

A glitch is defined as any transition that crosses logic threshold more than once between samples. It can be caused by capacitive coupling between traces, by power supply ripples, or a number of other events. Since a glitch can cause major problems in your system, you can use the Glitch mode to find it.

Your logic analyzer has the capability of triggering on a glitch and capturing all the data that occurred before it. The glitch must have a width of at least 5 ns at threshold in order for the analyzer to detect it.

If you want your timing analyzer to trigger on a glitch in the data, set the Acquisition mode to Glitch. This causes several changes in the analyzer. One change is that a field for glitch detection in each label is added to the Timing Trace Specification menu, as shown:

Then find
Edge
or
Glitch

Figure 16-4. Glitch Specification Field

With these glitch detection fields you specify on which channel or channels you want the analyzer to look for a glitch. These fields are discussed in more detail in “Then Find Edge” later in this chapter.

Glitch Acquisition mode causes the storage memory to be cut in half from 1k to 512. Half the memory (512) is allocated for storing the data sample, and the other half for storing the second transition of a glitch in a sample. Every sample is stored.

The sample rate varies from 20 Hz to 50 MHz (50 Ms/sample to 20 ns/sample) and is automatically selected by the timing analyzer to insure complete data in the window of interest.

When your timing analyzer triggers on a **glitch** and displays the data, the **glitch** appears in the waveform display as shown below.

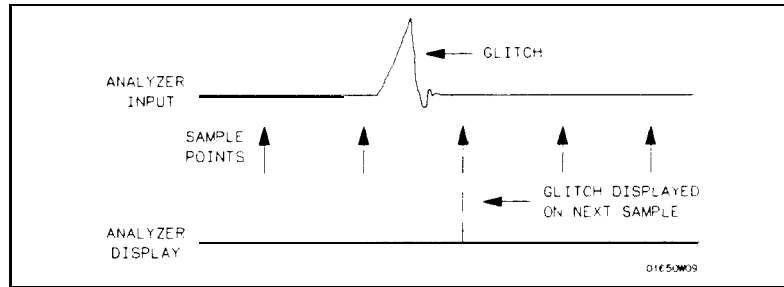

Figure 18-5. Glitch in Timing Waveform

Label The Label fields contain the labels that you define in the Timing Format Specification menu. If there are more labels than can fit on screen, use the left/right ROLL key and the KNOB to view those that are not displayed.

Base The **Base** fields allow you to specify the numeric base in which you want to define a pattern for a label. The Base fields also let you use a symbol that was specified in the Timing Symbol Table for the pattern. Each label has its own base defined separately from the other labels. If you select one of the Base fields, you will see the following pop-up menu. Decide which base you want to define your pattern in and select that option.

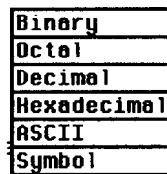

Figure 18-6. Base Pop-up Menu

One of the options in the Base pop-up is ASCII . It allows you to see characters that are represented by the pattern you specified in the **Find Pattern** field.

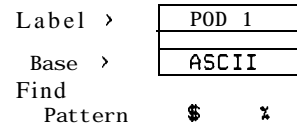

Figure 18-7. ASCII Defined as Numeric Base

Notice in the figure above that the **Find Pattern** field is no longer a selectable field when the base is ASCII . You cannot specify ASCII characters directly. You must specify a pattern in one of the other bases; then you can switch the base to ASCII and see what characters the pattern represents.

The Symbol option in the Base pop-up allows you to use a symbol that has been specified in the Timing Symbol Tables as a pattern or specify absolute and enter another pattern. You specify the symbol you want to use in the **Find Pattern** field.

Find Pattern

With the **Find Pattern** fields, you configure your timing analyzer to look for a certain pattern in the data. Each label has its own pattern field that you use to specify a pattern for that label.

During a run, the logic analyzer looks for a pattern in your data which is the logical AND of all the labels' patterns. That is, it looks for a simultaneous occurrence of the specified patterns. When it finds the pattern, it triggers at the point that you specified in the **Then find Edge** fields. See "Then Find Edge" later in this chapter for more information about edge triggering.

You select a **Find Pattern** field with one of two methods. The first method is to place the cursor on the Find Pattern field and press SELECT. The second method is to place the cursor on the Find Pattern field and press one of the alphanumeric keys on the front-panel keypad. Both methods give you a pop-up similar to that shown in figure 18-8.

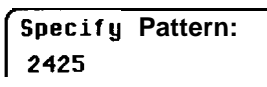

Figure 18-8. Specify Pattern Pop-Up for Find Pattern

The pop-up varies depending on the base you choose and the number of channels you assign to that label. If you press a key on the keypad to open the pop-up, the character on the key is placed in the first location of the pattern.

Enter your pattern in the pop-up and press SELECT. The pattern appears under the label in the **Find Pattern** field.

As mentioned previously in “Base”, if you specify ASCII as the base for the label, you won’t be able to enter a pattern. You must specify one of the other numeric bases to enter the pattern. Then you can switch the base to ASCII and see what ASCII characters the pattern represents. If you choose Symbols in the Base field, you can use one of the symbols specified in the Timing Symbol Tables as the pattern. The **Find Pattern** field looks similar to that below:

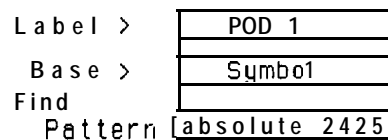

Figure 18-9. Symbol Defined in Base Field

If you select this field you get a pop-up similar to that shown:

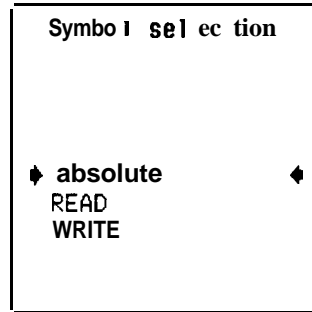

Figure 18-10. Symbol Selection Pop-Up for Find Pattern

The pop-up lists all the symbols defined for that label. It also contains an option “absolute **xxxx**.” Choosing this option gives you another pop-up with which you specify a pattern not given by one of your symbols.

To select an option from the pop-up, use the KNOB to scroll the symbols up and down until the desired symbol is between the two arrows. Press SELECT. The symbol name appears in the Find Pattern field under the label.

When you specify symbols in the Timing Symbol Tables, you also specify the number of characters in the symbol name that are to be displayed. If you specify only three characters of a symbol name in the Symbol menu, only REA of READ and WRI of WRITE would be displayed in the Find Pattern Field. In addition, only the first three letters of “absolute” would be displayed.

Pattern Duration (present for _____)

There are two fields with which you specify the Pattern Duration. They are located next to **present for _____** in the Timing Trace Specification menu. You use these fields to tell the timing analyzer to trigger before or after the specified pattern has occurred for a given length of time.

The first **field** can be set to ">" (greater than) or "<" (less than). If you place the cursor on this **field** and press SELECT, it toggles between > and <. The second field specifies the duration of the pattern. If you select > in the first field, you can set the duration to a value between 30 **ns** and 10 ms. If you select < in the first field, you can set the duration to a value between 40 ns and 10 ms. If you attempt to set the duration to a value outside the given range, the analyzer will automatically set it to the nearest limit.

To change the value of the pattern duration, place the cursor on the second field and either press SELECT to get a pop-up menu, or just press one of the numeric keys on the front-panel keypad. Both methods give you a Numeric Entry pop-up similar to that shown.

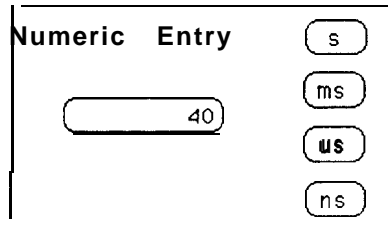

Figure 16-1 1. Pattern Duration (present for) Pop-Up

With the front-panel keypad, enter the desired pattern duration. Use the KNOB to place the cursor on the correct timing units, then press SELECT. Your value for Pattern Duration will appear in the field.

Note 

If you press a key on the keypad to open the pop-up, the number that you pressed will appear in the entry **field** replacing the previous value. To restore the original value press the CLEAR ENTRY key.

As an example, suppose you configure the **present for** field as shown:

present for > 50 ns

Figure 18-12. Example of Pattern Duration (Greater Than)

This configuration tells the timing analyzer to look for the pattern you specified that occurs for a period of time greater than 50 ns. Once the timing analyzer has found the pattern, it can look for the trigger.

Choosing < (less than) forces glitch and edge triggering off, and the timing analyzer triggers immediately at the end of the pattern that meets the duration requirements. The fields with which you specify edges and glitches do not appear in the menu. For instance, configure the **present for** field as shown below.

present for < 100 ns

Figure 18-13. Example of Pattern Duration (Less Than)

The analyzer triggers when it sees the pattern you specified, and that occurs for a period less than 100 ns. The pattern must also be valid for at least 20 ns.

Then Find Edge

With the **Then find Edge** fields you can specify the edges (transitions) of the data on which your timing analyzer triggers. You can specify a positive edge, a negative edge, or either edge. Each label has its own edge trigger specification field so that you can specify an edge on any channel.

When you specify an edge on more than one channel, the timing analyzer logically **ORs** them together to look for the trigger point. That is, it triggers when it sees any one of the edges you specified. It also **ANDs** the edges with the pattern you specified in the Find Pattern fields. The logic analyzer triggers on an edge following the valid duration of the pattern while the pattern is still present. To specify an edge, place the cursor on one of the **Then find Edge** fields and press **SELECT**. You will see a pop-up similar to that shown in the following figure.

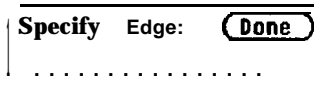

Figure 18-14. Specify Edge Pop-Up for Then Find Edge

Your pop-up may look different than this depending on the number of channels you assigned to the label. Each period in the pop-up indicates that no edge is specified for that channel.

To specify a negative edge, place the cursor on one of the periods in the pop-up and press SELECT once. The period changes to ↓, as shown:

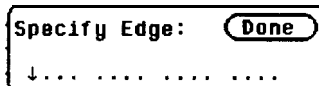

Figure 18-15. Negative Edge Specified

To specify a positive edge, place the cursor on one of the periods and press SELECT twice. The period changes to ↑, as shown:

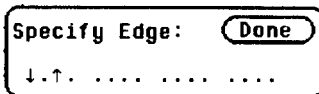

Figure 18-18. Positive Edge Specified

If you want the analyzer to trigger on either a positive or a negative edge, place the cursor on a period and press SELECT three times. The period changes to ↓↑, as shown:

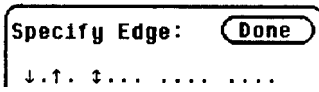



Figure 18-17. Either Edge Specified

If you want to delete an edge specification, place the cursor on the arrow for that channel and press SELECT until you see a period. To clear an entire label, press the CLEAR ENTRY key on the front panel.

When you have finished specifying edges, place the cursor on the Done field and press SELECT to close the pop-up.

Note 

If you are not in Binary base, you will see dollar signs (\$\$.) in the Then find Edge field when you close the pop-up. These indicate that edges have been specified; however, the logic analyzer can't display them correctly unless you have selected Binary for the base.

When you set the Acquisition mode on **Glitch**, a glitch detection field, for each label, is added to the screen. These fields allow you to specify glitch triggering on your timing analyzer. Selecting one of these fields displays the following pop-up menu.



Figure 18-18. Specify Glitch Pop-Up for Then Find Glitch

Your pop-up may look different depending on the number of channels you have assigned to the label. Each period indicates that the channel has not been specified for glitch triggering.

To specify a channel for glitch triggering, place the cursor on one of the periods and press SELECT. The period is replaced with an asterisk, indicating that the logic analyzer will trigger on a glitch on this channel.

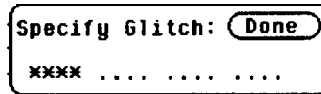

Figure 18-19. Glitches Specified

If you want to delete a glitch specification, place the cursor on the asterisk and press **SELECT**. The asterisk is replaced with a period.



If you are not in Binary base, you will see dollar signs (\$\$.) in the Glitch field when you close the pop-up. This indicates that glitches have been specified; however, the logic analyzer can't display them correctly unless you have selected Binary for the base.

When more than one glitch has been specified, the logic analyzer logically **ORs** them together. In addition, the logic analyzer **ORs** the glitch specifications with the edge specifications, then **ANDs** the result with the pattern you specified in the Find Pattern fields in order to **find** the trigger point. A boolean expression illustrating this is:

$(\text{glitch} + \text{glitch} + \text{edge} + \text{edge}) * \text{pattern}$



If you select < (less than) in the **present for ___ field**, edge and glitch triggering are turned off. The Then **find** Edge or Glitch field no longer appears on the screen. The logic analyzer then triggers only on the pattern specified in the Find Pattern fields.

Timing Waveforms Menu

Introduction

The Timing Waveforms menu is the display menu of the timing analyzer. This chapter describes the Timing Waveforms menu and how to interpret it. It also tells you how to use the fields to manipulate the displayed data so you can find your measurement answers.

There are two different areas of the timing waveforms display: the menu area and the waveforms area. The menu area is in the top one-fourth of the screen and the waveforms area is the bottom three-fourths of the screen.

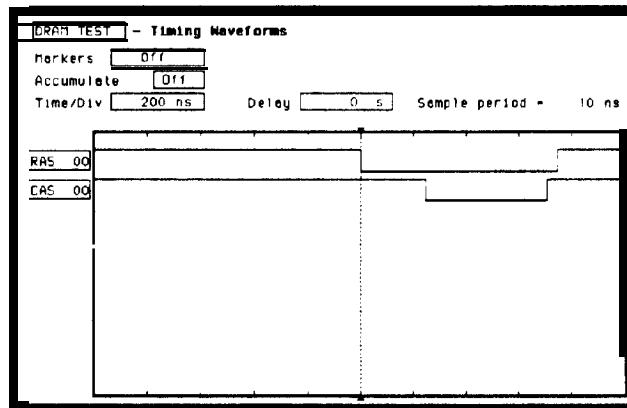

Figure 19-1. Timing Waveforms Menu

The waveforms area displays the data that the timing analyzer acquires. The data is displayed in a format similar to an oscilloscope with the horizontal axis representing time and the vertical axis representing amplitude. The basic differences between an oscilloscope display and the timing waveforms display are: in the timing waveforms display the vertical axis only displays highs (above threshold) and lows (below threshold). Also, the waveform lows are represented by a thicker line for easy differentiation.

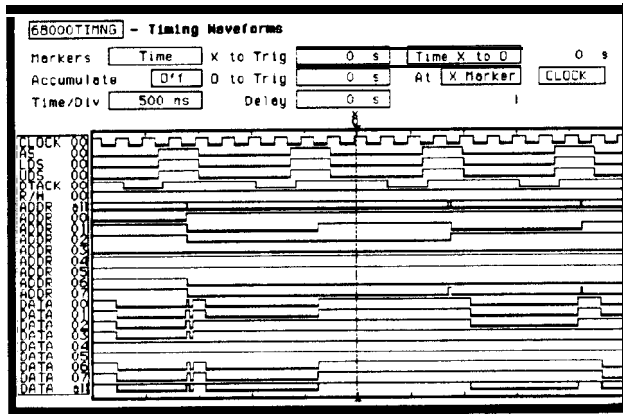

Figure 19-2. Timing Waveforms Menu with 24 Waveforms

Accessing the Timing Waveforms Menu

The Timing Waveforms Menu is accessed by the pressing the DISPLAY key on the front panel when the timing analyzer is on. It will automatically be displayed when you press RUN.

Timing Waveforms Menu Fields

The menu area contains fields that **allow** you to change the display parameters, place markers, and display waveform measurement parameters.

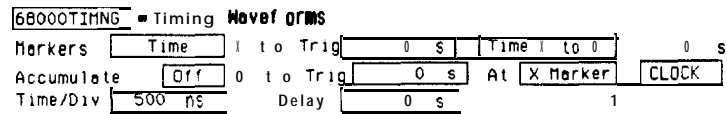

Figure 19-3. Timing Waveforms Menu Fields

Markers

The **Markers** field allows you to specify how the X and 0 markers will be positioned on the timing data. The options are:

- Off
- Time
- Patterns
- Statistics
- Markers Off/Sample Period

When the markers are off they are not visible and the sample period is displayed. In transitional timing mode, the sample period **will** always be 10 ns. In Glitch mode, the sample period is controlled by the **Time/Div** setting and can be monitored by turning the markers off.



Note

The sample period displayed is the sample period of the last acquisition. If you change the **Time/Div** setting, you must press RUN to initiate another acquisition before the sample period is updated.

Although the markers are off, the logic analyzer still performs statistics, so if you have specified a stop measurement condition the measurement will stop if the pattern specified for the markers is found.

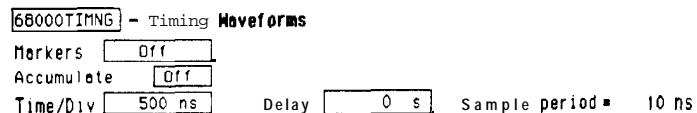

Figure 19-4. Markers Off

Markers Time

When the markers are set to Time, you can place the markers on the waveforms at events of interest and the logic analyzer will tell you:

- Time X to **Trig(ger)**.
- Time 0 to **Trig(ger)**.
- **Time X to 0**.

To position the markers, move the cursor to the field of the marker you wish to position and press SELECT. A pop-up will appear showing the current time for that marker. Either rotate the KNOB or enter a numeric value from the keypad to change the position of that marker. Pressing SELECT when you are finished positions the marker and closes the pop-up.

When the cursor is on either the **X to Trig** or **0 to Trig** fields, you can also enter a value directly from the keypad without pressing SELECT.

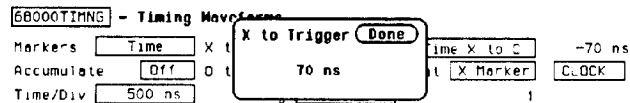

Figure 19-5. Markers Time

The **Time X to 0** field will change according to the position of the X and 0 markers. If you place the cursor on the Time X to 0 field and press SELECT, another pop-up will appear showing you all three times: X to Trigger, 0 to Trigger, and Time X to 0.

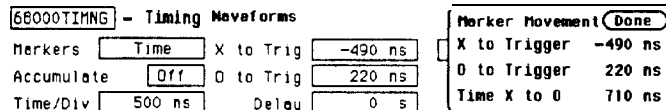

Figure 19-6. Time X to 0 Pop-up

If you rotate the KNOB while this pop-up is open, both X and 0 markers will move, but the relative placement between them will not change.

Markers Patterns

When the markers are set to patterns, you can specify the patterns on which the logic analyzer will place the markers. You can also specify how many occurrences of each marker pattern the logic analyzer looks for. This use of the markers allows you to **find** time between specific patterns in the acquired data.

Figure 19-7. Markers Patterns

Patterns for each marker (X and 0) can be specified. Patterns can be specified for both markers in each label. The logic analyzer searches for the logical “and” of patterns for all labels even though only one label can be displayed at a time. You can also specify whether the marker is placed on the pattern at the beginning of its occurrence (entering) or at the end of its occurrence (leaving) as shown in figure 19-8.

Figure 19-8. Marker Patterns Pop-up menu

Stop Measurement

Another feature of markers set to patterns is the Stop measurement when **Time X-O** _____. The options are: Less than, Greater than, In range, Not in range

With this feature you can use the logic analyzer to look for a specified time or range of time between the marked patterns and have it stop acquiring **data** when it sees this time between markers. (The X marker must precede the 0 marker.)

Also available is **Store exception to disk** which allows you to specify a **file** on the disk that exceptions can be stored in. The default filename is EXCEPTION.

Note

The upper and lower range boundaries must not be the same value. For example, if you want to stop a measurement when the X and 0 markers are in range of 200 ns, you should set the range values to 190 ns and 210 ns. This eliminates erroneous measurement termination.

Markers Statistics

When statistics are specified for markers, the logic analyzer will display the following:

- Number of total runs.
- Number of valid runs (runs where markers were able to be placed on specified patterns).
- Minimum time between the X and 0 markers.
- Maximum time between the X and 0 markers.
- Average time between the X and 0 markers.

Statistics are based on the time between markers which are placed on specific patterns. If a marker pattern is not specified, the marker will be placed on the trigger point by the logic analyzer. In this case the statistical measurement will be the time from the trigger to the specified marker. How the statistics will be updated depends on the timing trace mode (repetitive or single).

In repetitive, statistics will be updated each time a valid run occurs until you press STOP. When you press RUN after STOP, the statistics will be cleared and will restart from zero.

In single, each time you press RUN an additional valid run will be added to the data and the statistics will be updated. This will continue unless you change the placement of the X and 0 markers between runs.

Accumulate Mode

Accumulate mode is selected by toggling the Accumulate ON/OFF field in the Timing Waveforms menu. When accumulate is on, the timing analyzer displays the data from a current acquisition on top of the previously acquired data.

When the old data is cleared depends on whether the trace mode is in single or repetitive. In single, new data will be displayed on top of the old each time RUN is selected as long as you stay in the Timing Waveforms menu between runs. Leaving the Timing, Waveforms menu always clears the accumulated data. In repetitive mode, data is cleared from the screen only when you start a run after stopping acquisition with the STOP key.

At _____
Marker _____

The **At X (or 0) Marker _____** fields allow you to select either the X or 0 markers. You can place these markers on the waveforms of any label and have the logic analyzer tell you what the pattern is. For example, in the timing waveforms display (figure 19-9) the number 35 to the right of the **Delay _____** field is the pattern in hexadecimal that is marked by the 0 marker. The base of the displayed field is determined by the base of the specified label you selected in the Timing Trace menu.

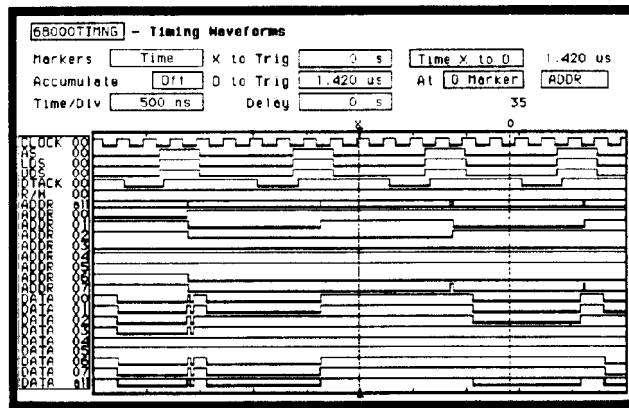

Figure 19-9. At 0 Marker ADDR fields

This display tells you that 35H is the pattern on the address label lines where the 0 marker is located.

The next field to the right of the **At _____ Marker** field will pop up when selected and show you all the labels assigned to the timing analyzer as shown below.

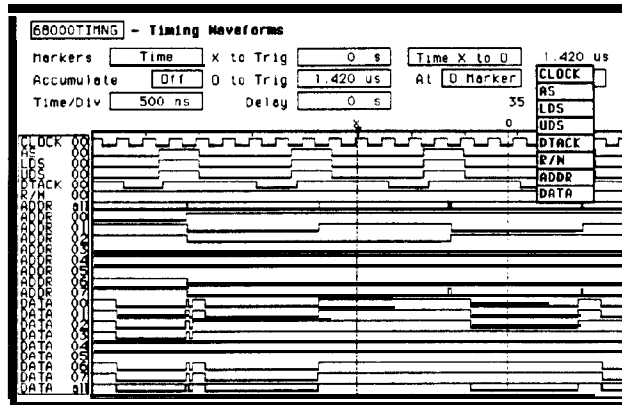

Figure 19-10. Label Option Pop-up

Time/Div (time per division) Field

The time per division field allows you to change the width of the time window of the Timing Waveforms menu.

When the pop-up is open you can change the time per division by rotating the KNOB or entering a numeric value from the keypad. When you rotate the KNOB, the time per division increments or decrements in 1-2-5 sequence from 10 ns/div to 50 ms/div.

Note

Sample period is fixed at 10 ns in the Transitional acquisition mode.

When you enter a value from the keypad, the time per division does not have to be a 1-2-5 sequence.

Note

In Glitch mode, changing the Time/Div setting changes the sample period for the next run. To view the sample period after the next run, turn the markers off if they are on and press RUN.

Delay Field

The Delay field allows you to enter a delay. The delay can be either positive or negative. Delay allows you to place the time window (selected by **Time/Div**) of the acquired data at center screen.

The inverted triangle in the horizontal center of the waveforms area of the display represents trigger + delay. The vertical dotted line represents the trigger point (see figure 19-11).

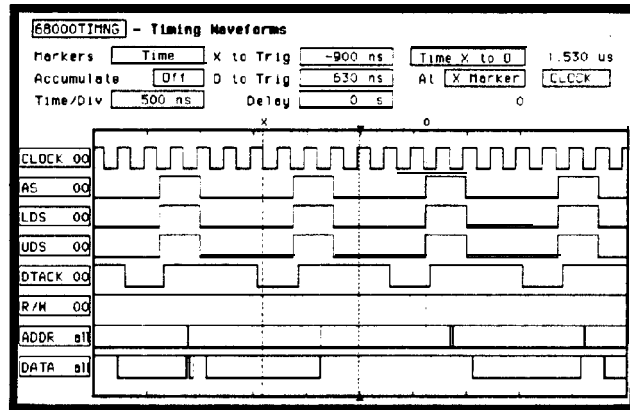

Figure 19-11. Trigger and Trace Points

If you want to trace after the trigger point, enter a positive delay. If you want to trace before the trigger point (similar to negative time) enter a negative delay. The logic analyzer is capable of maximum delays of $- 2500$ seconds to $+ 2500$ seconds. In Transitional mode the maximum delay is determined by the number of transitions of the incoming data. Data may not be displayed at all settings of **Time/Div** and Delay.

In Glitch mode the maximum delay is 25 seconds, which is controlled by memory and sample period (512 x 50ms). The sample rate is also dependent on the delay setting. It is represented by the following formula:

if delay < 20 ns

Hwdelay = 20 ns (this is an instrument constant)

if delay > 10 ms

Hwdelay = 10 ms

else Hwdelay = delay (delay setting in timing waveforms menu)

Sample period = larger of:

Time/Div ÷ 25 or

absolute value [(delay - Hwdelay) ÷ 256]

If sample period > 50 ms

Then sample period = 50 ms

Timing Analyzer Measurement Example

Introduction

In this chapter you will learn how to use the timing analyzer by setting up the logic analyzer to simulate a simple timing measurement. Since you may not have the same test circuit available, we will give you the measurement results as actually measured by the logic analyzer,

The exercise in this chapter is organized in a task format. The tasks are ordered in the same way you will most likely use them once you become an experienced user. The steps in this format are both numbered and lettered. The numbered steps state the step objective. The lettered steps explain how to accomplish each step objective. There is also an example of each menu after it has been properly set up.

How you use the steps depends on how much you remember from chapters 1 through 4 of the Getting *Started* Guide . If you can set up each menu by just looking at the menu picture, go ahead and do so. If you need a reminder of what steps you need to perform, follow the numbered steps. If you still need more information about “how,” use the lettered steps.

To gain confidence using your logic analyzer, we recommend that you configure the menus as you follow the simulated measurement example up to section “Acquiring the Data.” From that section unto the end, you will see the measurement results on the Timing Waveforms screen as if you had the real test circuit connected, and as if you had selected RUN.

Problem Solving with the Timing Analyzer

In this exercise, assume you are designing a dynamic RAM memory (DRAM) controller and you must verify the timing of the row address strobe (RAS) and the column address strobe (CAS). You are using a **4116** dynamic RAM and the data book specifies that the minimum time from when LRAS is asserted (goes low) to when LCAS is no longer asserted (goes high) is 250 ns. You could use an oscilloscope but since the timing analyzer will do just **fine** when you don't need voltage **parametrics** you decide to go ahead and use the logic analyzer.

What Am I Going to Measure?

After configuring the logic analyzer and hooking it up to your circuit under test, you will be measuring the time (x) from when the RAS goes low to when the CAS goes high, as shown below.

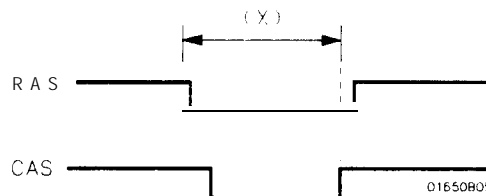

Figure 20-I. RAS and CAS Signals

How Do I Configure the Logic Analyzer?

In order to make this timing measurement, you must configure the logic analyzer as a timing analyzer. By following these steps you will configure Analyzer 1 as the timing analyzer.

If you are in the System Configuration menu you are in the right place to get started and you can start with step 2; otherwise, start with step 1.

1. Using the field in the upper left corner of the display, get the System Configuration menu on screen.
 - a. Place the cursor on the field in the upper left corner of the display and press SELECT.
 - b. Place the cursor on System and press SELECT.
2. In the System Configuration menu, change Analyzer 1 type to Timing. If analyzer 1 is already a timing analyzer, go on to step 3.
 - a. Place the cursor on the Type: field and press SELECT.
 - b. Place the cursor on Timing and press SELECT.

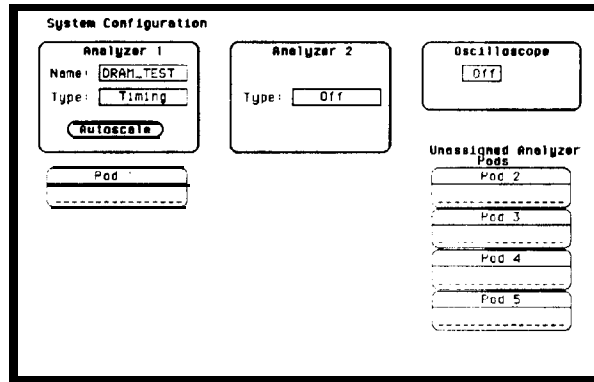

Figure 20-2. System Configuration Menu

3. Name Analyzer 1 “DRAM TEST” (optional)
 - a. Place the cursor on the Name: ____ field of Analyzer 1 and press SELECT.
 - b. With the Alpha Entry pop-up, change the name to “DRAM TEST” (see “How to Enter Alpha Data” in chapter 3 if you need a reminder).
4. Assign pod 1 to the timing analyzer.
 - a. Place the cursor on the Pod 1 field and press SELECT.
 - b. In the Pod 1 pop-up, place the cursor on Analyzer 1 and press SELECT.

Connecting the Probes

At this point, if you had a target system with a 4116 DRAM memory IC, you would connect the logic analyzer to your system.

Since you will be assigning Pod 1 bit 0 to the RAS label, you hook Pod 1 bit 0 to the memory IC pin connected to the RAS signal. You hook Pod 1 bit 1 to the IC pin connected to the CAS signal.

Activity Indicators

When the logic analyzer is connected and your target system is running, you will see activity indicators, as shown below, at the right-most end (least significant bits) of the Pod 1 field in the System Configuration menu. This indicates the RAS and CAS signals are transitioning.

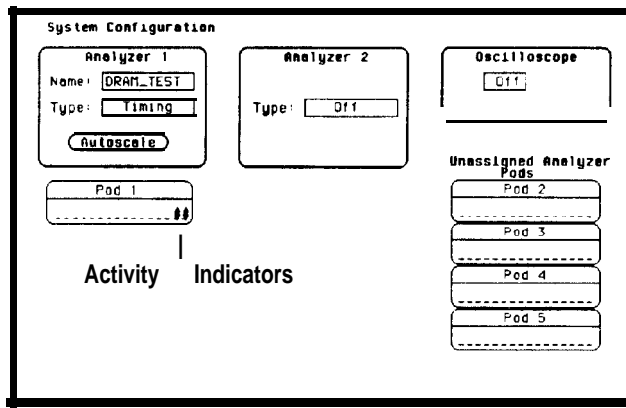

Figure 20-3. Activity Indicators

Configuring the Timing Analyzer

Now that you have configured the system, you are ready to configure the timing analyzer. You will be:

- . Creating two names (labels) for the input signals
 - . Assigning the channels connected to the input signals
 - Specifying a trigger condition
1. Display the Timing Format Specification menu.
 - a. Press the FORMAT key on the front panel.
 2. Name two labels, one RAS and one CAS.
 - a. Place the cursor on the top field in the label column and press SELECT.
 - b. Place the cursor on Modify label and press SELECT.

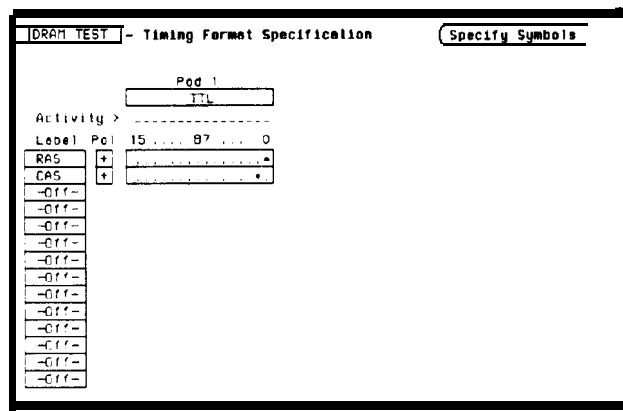

Figure 20-4. Timing Format Specification Menu

- c. With the Alpha Entry pop-up, change the name of the label to RAS.

- d. Name the second label CAS by repeating steps a through c.
3. Assign the channels connected to the input signals (Pod **1** bits 0 and **1**) to the labels RAS and CAS respectively.
 - a. Place the cursor on the bit assignment field below Pod 1 and to the right of RAS and press SELECT.
 - b. Any combination of bits may be assigned to this pod; however, you will want only bit 0 assigned to the RAS label. The easiest way to assign bits is to press the CLEAR ENTRY key to un-assign any assigned bits before you start.
 - c. Place the cursor on the period under the 0 in the bit assignment pop-up and press SELECT . This will place an asterisk in the pop-up for bit 0 indicating Pod 1 bit 0 is now assigned to the RAS label. Place cursor on Done and press SELECT to close the pop-up.
 - d. Assign Pod 1 bit 1 to the CAS label by moving the cursor to bit 1 and pressing SELECT.

Specifying a Trigger Condition

To capture the data and then place the data of interest in the center of the display of the Timing Waveforms menu, you need to tell the logic analyzer when to trigger. Since the first event of interest is when the LRAS is asserted (negative-going edge of RAS), you need to tell the logic analyzer to trigger on a negative-going edge of the RAS signal.

1. Select the Timing Trace menu by pressing the TRACE key.
2. Set the trigger so that the logic analyzer triggers on the negative-going edge of the RAS.
 - a. Place the cursor on the Then find Edge field under the label RAS, then press SELECT.
 - b. Place the cursor on the . (period) in the pop-up and press SELECT once. Pressing SELECT once in this pop-up changes a period to ↓ which indicates a negative-going edge.
 - c. Place the cursor on Done and press SELECT. The pop-up closes and a \$ will be located in this field. The \$ indicates an edge has been specified even though it can't be shown in the HEX base.

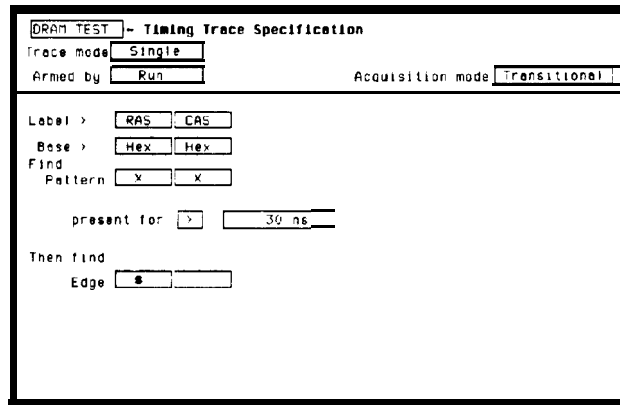

Figure 20-5. Trigger Edge Specified

Acquiring the Data

Now that you have configured and connected the logic analyzer, you acquire the data for your measurement by pressing the RUN key. The logic analyzer will look for a negative edge on the RAS signal and trigger if it sees one. When it triggers, the display switches to the Timing Waveforms menu.



From this point in the exercise unto the end, we will give you the measurement results. This way, you will not have to obtain and use an identical circuit.

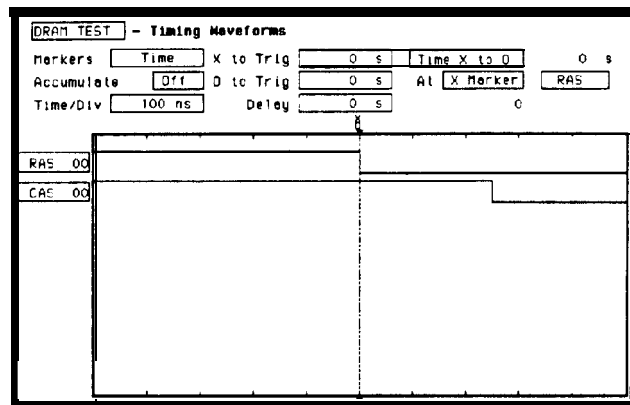

Figure 20-6. Timing Waveforms Menu

The RAS label shows you the RAS signal and the CAS label shows you the CAS signal. Notice the RAS signal goes low at or near the center of the waveform display area (horizontal center).

The Timing Waveforms Menu

The Timing Waveforms menu differs from the other menus you have used so far in this exercise. Besides displaying the acquired data, it has menu fields that you use to change the way the acquired data is displayed and fields that give you timing answers. Before you can use this menu to **find** answers, you need to know some of the special symbols and their functions. The symbols are:

- The X and O
- The ▼
- The vertical dotted line

The X and O

The X and O are markers you use to **find** your answer. You place them on the points of interest on your waveforms, and the logic analyzer displays the time between the markers. The X and O markers will be in the center of the display when X to trig (ger) and O to trig (ger) are both 0.000 s (see example below).

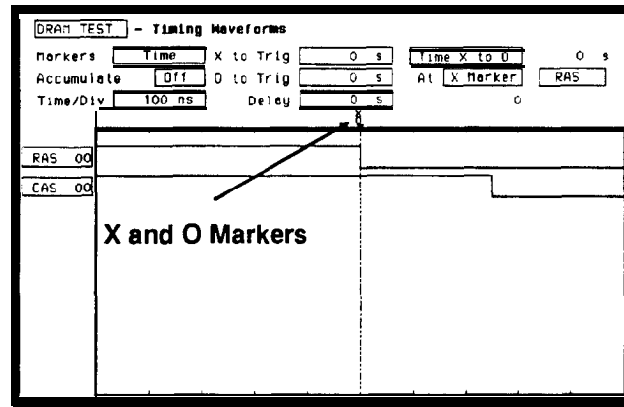

Figure 20-7. X & O Markers

The ▼ The (inverted triangle) indicates the trace point. Remember, trace point = trigger + delay. Since delay in this example is 0.000 s, you will see the negative-going edge of the RAS signal at center screen under the .

The Vertical Dotted Line The vertical dotted line indicates the trigger point you specified in the Timing Trace Specification menu. The vertical dotted line is at center screen under the inverted triangle and is superimposed on the negative-going edge of the RAS signal.

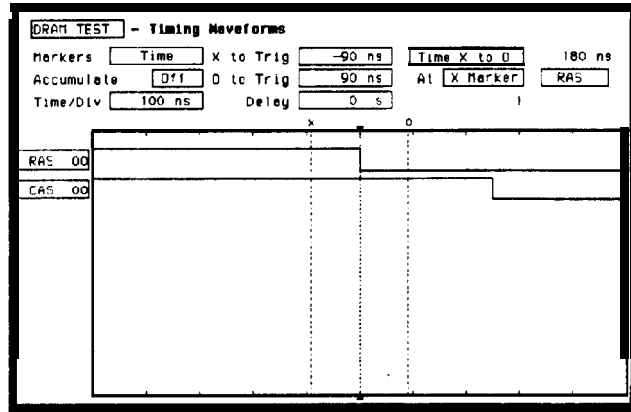

Figure 20-8. Inverted Triangle & Vertical Dotted Line

Configuring the Display

Now that you have acquired the RAS and CAS waveforms, you need to **configure** the Timing Waveforms menu for best resolution and to obtain your answer.

Display Resolution

You get the best resolution by changing the **Time/Div** to a value that displays one negative-going edge of both the RAS and CAS waveforms. Set the **Time/Div** by following these steps.



Figure 20-9. RAS and CAS Signals

1. Place the cursor on **Time/Div** and press SELECT. The Time/Div pop-up appears, showing you the current setting.
2. While the pop-up is present, rotate the KNOB until your waveform shows you only one negative-going edge of the RAS waveform and one positive-going edge of the CAS waveform (see above). In this example 200 ns is best.

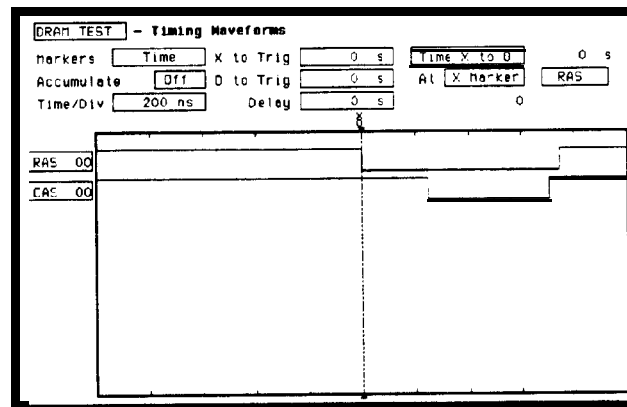

Figure 20-10. Changing Time/Div.

Making the Measurement

What you want to know is how much time elapses between the time RAS goes low and the time CAS goes high again. You will use the X and 0 markers to quickly **find** the answer. Remember, you specified the negative-going edge of the RAS to be your trigger point; therefore, the X marker should be on this edge if X to Trig = 0. If not, follow steps 1 and 2.

1. Place the cursor on the X to Trig field and press SELECT . A pop-up **will** appear showing you the current time from the X marker to the trigger; however, you don't need to worry about this number now.
2. Rotate the KNOB to place the X marker on the negative-going edge of the RAS waveform and press SELECT. The pop-up closes and displays X to Trig = 0.000 s.
3. Place the cursor on 0 to Trig and press SELECT. Repeat step 2 except place the 0 marker on the positive-going edge of the CAS waveform and press SELECT. The pop-up closes and displays 0 to Trig = 710 ns.

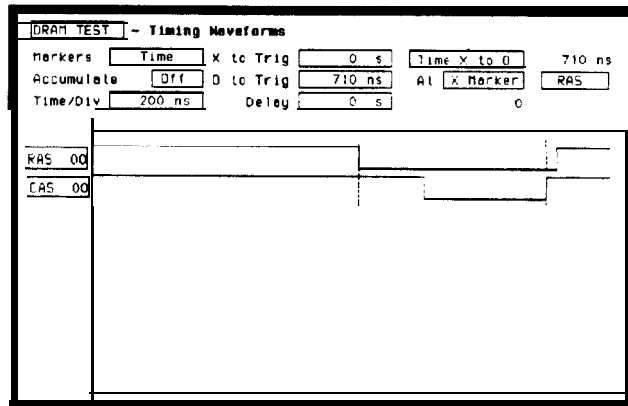

Figure 20-1 1. Marker Placement

Finding the Answer

Your answer could be calculated by adding the X to Trig and 0 to Trig times, but you don't need to bother. The logic analyzer has already calculated this answer and displays it in the **Time X to 0** field.

This example indicates the time is 710 ns. Since the data book specifies a minimum of 250 ns, it appears your DRAM controller circuit is designed properly.

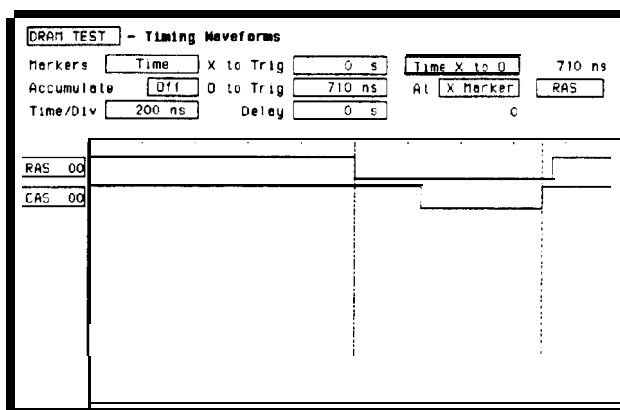

Figure 20-12. Time X to 0

Summary

You have just learned how to make a simple timing measurement with the HP **1652B/53B** logic analyzer. You have learned to do the following:

- Specified a timing analyzer.
- Assigned pod 1.
- Assigned bits.
- Assigned labels.
- **Specified** a trigger condition.
- Learned which probes to connect.
- Acquired the data.
- Configured the display.
- Set the **Time/Div** for best resolution.
- Positioned the markers for the measurement answer.

You have seen how easy it is to use the timing analyzer to make timing measurements that you could have made with a scope. You can use the timing analyzer for any timing measurement that doesn't require voltage **parametrics** or doesn't go beyond the accuracy of the timing analyzer.

Timing/State Measurement Example

Introduction

In this chapter you will learn how to use the timing and state analyzers interactively by setting up the logic analyzer to simulate a simple timing/state measurement. Since you may not have the same test circuit available, we will give you the measurement results as actually measured by the logic analyzer.

The exercise in this chapter is organized differently than the exercises in the previous chapters. Since you have already set up both the timing and state analyzers, you should be ready to set them up for this simulated measurement by just looking at the menu pictures.

Any new set-ups in this exercise will be explained in task format steps like the previous chapters.

To gain confidence using your logic analyzer, we recommend that you configure the menus as you follow the simulated measurement example up to section "Acquiring the Data." From that section unto the end, you will see the measurement results on the display screens as if you had the real test circuit connected, and as if you had selected RUN.

Problem Solving with the Timing/State Analyzer

In this example assume you have designed a microprocessor-controlled circuit. You have completed the hardware, and the software designer has completed the software and programmed the ROM (read-only memory). When you turn your circuit on for the first time, your circuit doesn't work properly. You have checked the power supply voltages and the system clock, and they are working properly.

Since the circuit has never worked before, you and the software engineer aren't sure if it is a hardware or software problem. You need to do some testing to find a solution.

You also notice the circuit fails intermittently. More specifically, it only fails when the microprocessor attempts to address a routine that starts at address 8930.

What Am I Going to Measure?

To see what might be causing the failure, you decide to start where the microprocessor goes to the routine that starts at address 8930. The first thing you check is whether the microprocessor actually addresses address 8930. The next thing you check is whether the code is correct in all the steps in this routine.

Your measurement, then, requires verification of the following:

- Whether the microprocessor addresses location 8930.
- Whether all the addresses within the routine are correct.
- Whether all the data at the addresses in the routine are correct.

If the routine is correct, the state listing displays the following:

```
+ 0000 008930 B03C
+ 0001 008932 61FA
+ 0002 008934 67F8
+ 0003 008936 B03C
+ 0004 00892E 61FA
```

How Do I Configure the Logic Analyzer?

In order to make this measurement, you must configure the logic analyzer as a state analyzer because you want to trigger on a specific state (8930). You also want to verify that the addresses and data are correct in the states of this routine.

Configure the logic analyzer so that Analyzer 1 is a state analyzer as shown below:

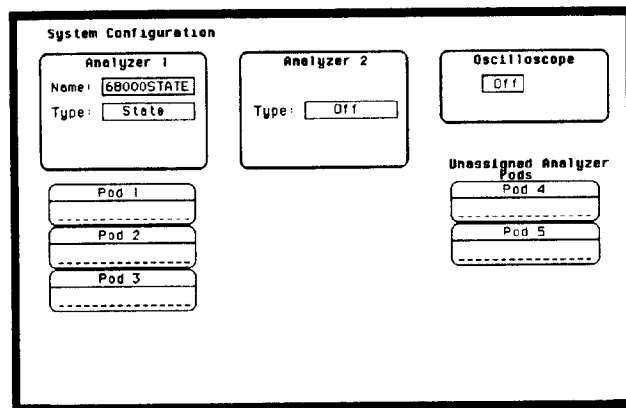

Figure 21-1. System Configuration Menu

Configuring the State Analyzer

Now that you have configured the system, you are ready to configure the state analyzer. Configure the State Format Specification menu as shown:

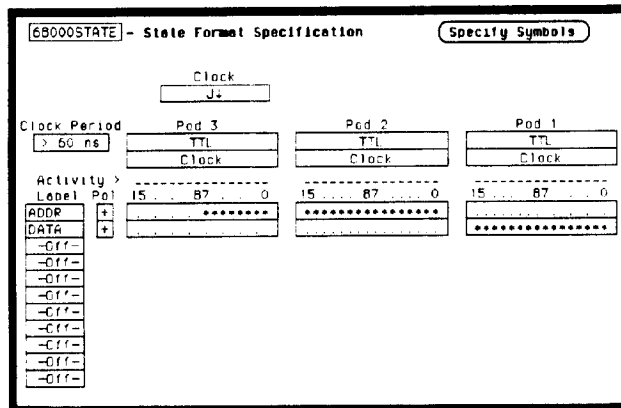

Figure 21-2. State Format Specification Menu

Configure the State Trace Specification menu as shown:

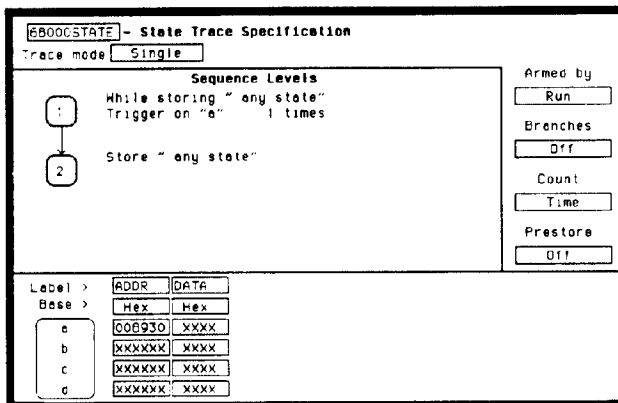

Figure 21-3. State Trace Specification Menu

Connecting the Probes

At this point, if you had a target system with a 68000 microprocessor, you would connect the logic analyzer to your system. Since you will be assigning labels ADDR and DATA, you will hook the probes to your system accordingly:

- Pod 1 probes 0 through 15 to the data bus lines D0 through D15.
- Pod 2 probes 0 through 15 to the address bus lines A0 through A15.
- Pod 3 probes 0 through 7 to the address bus lines A16 through A23.
- Pod 1, CLK (J clock) to the address strobe (LAS).

Acquiring the Data

Since you want to capture the data when the microprocessor sends address 8930 on the bus, you press the RUN key to arm the state analyzer. If the microprocessor sends address 8930, it will trigger the state analyzer and switch the display to the State Listing menu.



From this point in the exercise unto the end, we will give you the measurement results. This way, you will not have to obtain and use an identical circuit.

Finding the Problem

You look at this listing to see what the data is in states + 0000 through + 0004. You know your routine is five states long.

The 68000 does address location 8930, so you know that the routine is addressed. Now you need to compare the state listing with the following correct addresses and data:

```
+ 0000 008930 B03C
+ 0001 008932 61FA
+ 0002 008934 67F8
+ 0003 008936 B03C
+ 0004 00892E 61FA
```

As you compare the state listing (shown below) with the above data you notice the data at address 8932 is incorrect. Now you need to find out why.

Label	ADDR	DATA
Base	Hex	Hex
-0007	0C88CA	00FF
-0006	0C88CC	6730
-0005	0C88CE	4BE7
-0004	0C88FE	4E75
-0003	0C8900	3000
-0002	0004F4	0000
-0001	0004F6	8930
+0000	008930	B03C
+0001	008932	00FF
+0002	008934	67F8
+0003	008936	B03C
+0004	00892E	61FA
+0005	00B930	B03C
+0006	0004F4	0000
+0007	0004F6	B930
+0008	00B92A	4EFA

Figure 21-4. Incorrect Data

Your first assumption is that incorrect data is stored to this memory location. Assume this routine is in ROM since it is part of the operating system for your circuit. Since the ROM is programmed by the software designer, you have the software designer verify whether or not the data at address 8932 is correct. The software designer tells you that the data is correct. Now what do you do?

Now it's time to look at the hardware to see if it is causing incorrect data when the microprocessor reads this memory address. You decide you want to see what is happening on the address and data buses during this routine in the time domain.

In order to see the time domain, you need the timing analyzer.

What Additional Measurements Must I Make?

Since the problem exists during the routine that starts at address 8930, you decide you want to see the timing waveforms on the address and data bus when the routine is running. You also want to see the control signals that control the read cycle. You will then compare the waveforms with the timing diagrams in the 68000 data book.

Your measurement, then, requires verification of the following:

- Correct timing of the control signals.
- Stable addresses and data during the memory read.

The control signals you must check are listed below:

- System clock.
- Address strobe (AS).
- Lower and upper data strobes (LDS and UDS).
- Data transfer acknowledge (DTACK).
- Read/write (R/W).

How Do I Re-Configure the Logic Analyzer?

In order to make this measurement, you must re-configure the logic analyzer so Analyzer 2 is a timing analyzer. You leave Analyzer 1 as a state analyzer since you will use the state analyzer to trigger on address 8930.

Configure the logic analyzer so Analyzer 2 is a timing analyzer as shown:

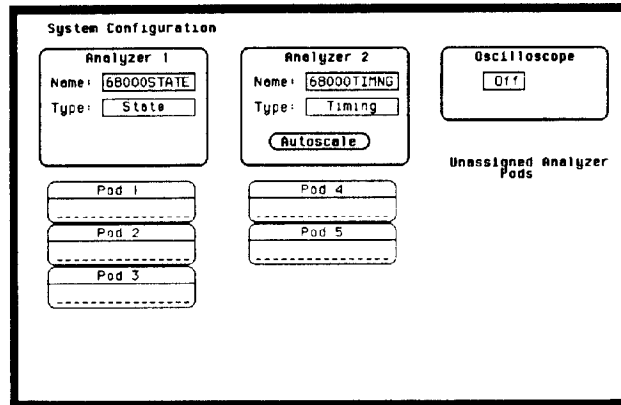

Figure 21-5. System Configuration Menu

Connecting the Timing Analyzer Probes

At this point you would connect the probes of pods 4 and 5 as follows:

- Pod 4 bit 0 to address strobe (AS).
- Pod 4 bit 1 to the system clock.
- Pod 4 bit 2 to low data strobe (LDS).
- Pod 4 bit 3 to upper data strobe (UDS).
- Pod 4 bit 4 to the read/write (R/W).
- Pod 4 bit 5 to data transfer acknowledge (DTACK).
- Pod 5 bits 0 through 7 to address lines A0 through A7.
- Pod 5 bits 8 through 15 to data lines D0 through D7.

Configuring the Timing Analyzer

Now that you have configured the system, you are ready to configure the timing analyzer. Configure the Timing Format Specification menu as shown:

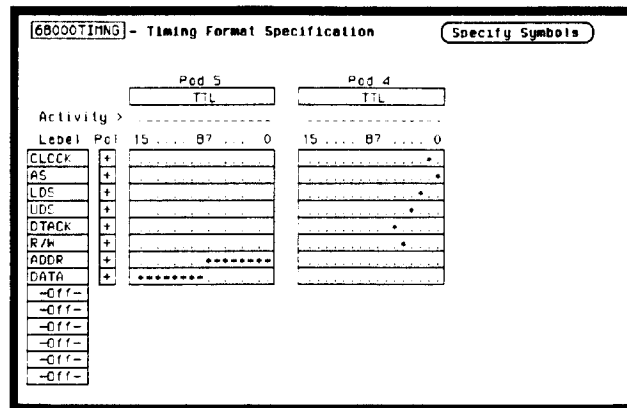

Figure 21-6. Timing Format Specification Menu

Configure the Timing Trace Specification as shown:

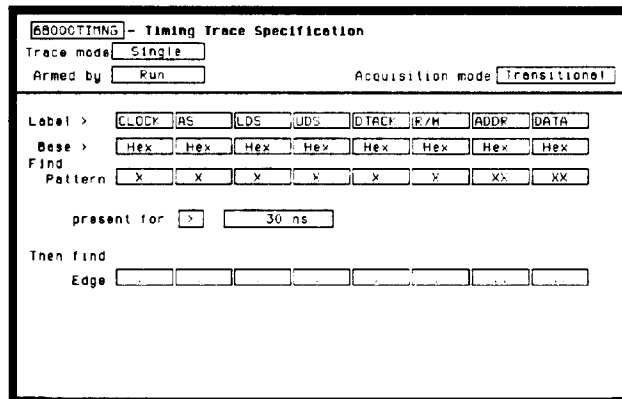

Figure 21-7. Timing Trace Specification Menu

Setting the Timing Analyzer Trigger

Your timing measurement requires the timing analyzer to display the timing waveforms present on the buses when the routine is running. Since you triggered the state analyzer on address 8930, you want to trigger the timing analyzer so the timing waveforms can be time correlated with the state listing.

To set up the logic analyzer so that the state analyzer triggers the timing analyzer, perform these steps:

1. Display the Timing Trace Specification menu.
2. Place the cursor on the **Armed by** ____ field and press SELECT.
3. Place the cursor on the 68000STATE option in the pop-up and press SELECT.

Your timing trace specification should match the menu shown:

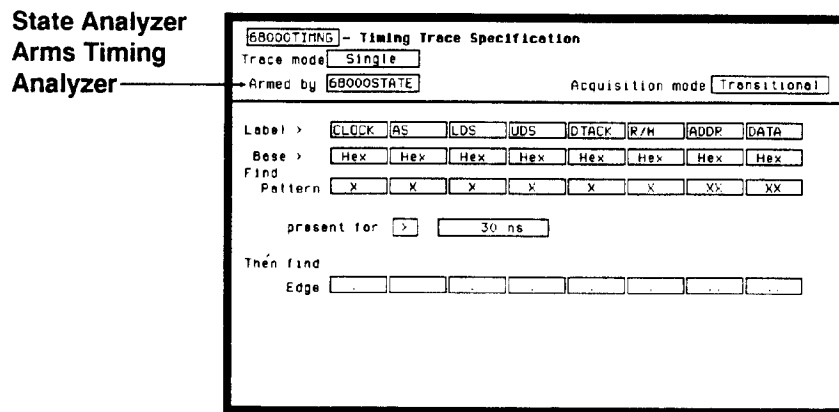

Figure 21-8. Armed by 68000 STATE

Time Correlating the Data

In order to time correlate the data, the logic analyzer must store the timing relationships between states. Since the timing analyzer samples asynchronously and the state analyzer samples synchronously, the logic analyzer must use the stored timing relationship of the data to reconstruct a time correlated display.

To set up the logic analyzer to keep track of these timing relationships, turn on a counter in the State Trace Specification menu. The following steps show you how:

1. Display the State Trace Specification menu.
2. Place the cursor in the field just below Count on the right side of the display and press SELECT.
3. Place the cursor on the Time option and press SELECT. The counter will now be able to keep track of time for the time correlation.

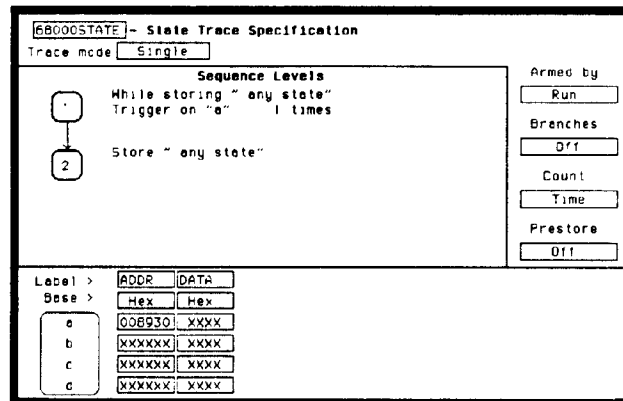

Figure 21-9. Count Set to Time

Re-acquiring the Data

After you connect the probes of pods 4 and 5 to your circuit, all you have to do is press RUN. When the logic analyzer acquires the data it switches the display to the State Listing menu unless you switched one of the other menus to the timing analyzer after reconfiguring the State Trace menu. Regardless of which menu is displayed, change the display to the Mixed Mode.

Mixed Mode Display

The Mixed mode display shows you both the State Listing and Timing Waveforms menus simultaneously. To change the display to the Mixed Mode:

1. Place the cursor on the field in the upper left corner of the display and press SELECT.
2. Place the cursor on Mixed Mode and press SELECT. You will now see the mixed display as shown:

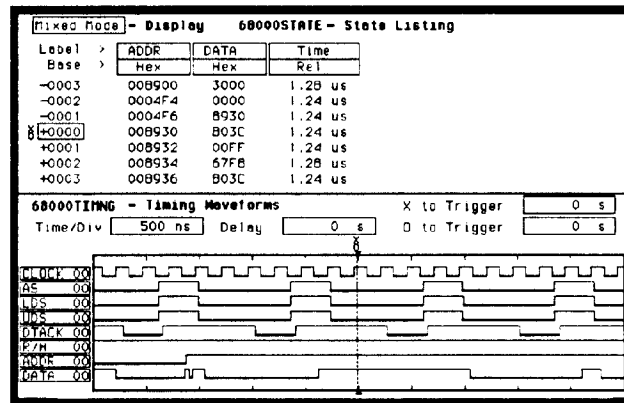

Figure 21-10. Mixed Mode Display

Interpreting the Display

In the Mixed Mode display the state listing is in the top half of the screen and the timing waveforms are in the lower half. The important thing to remember is that you time correlated this display so you could see what is happening in the time domain during the faulty routine.

Notice that the trigger point in both parts of the display is the same as it was when the displays were separate. The trigger in the state listing is in the box containing + 0000 and the trigger of the timing waveform is the vertical dotted line.

As you look at the mixed display, you notice nothing wrong except the data at address 8932 is incorrect. However, you are seeing only one bit each of the address and the data. To see all the data and addresses in the timing waveform part of the display, you must overlap them.

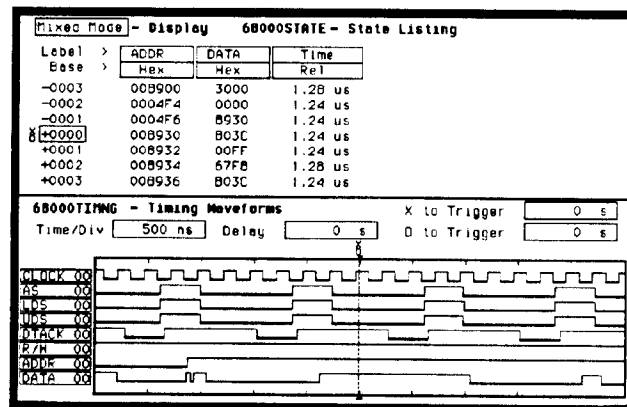

Figure 21-11. Interpreting the Display

Overlapping Timing Waveforms

Since you see nothing wrong with the timing waveforms so far, you think unstable data may be on the data lines during the read cycle. In order to see unstable data, you must be able to see all the data lines during the read and look for transitions. Overlapping the waveforms allows you to do this. To overlap waveforms, follow these steps:

1. Place the cursor on the 00 of the ADDR 00 label and press SELECT. The following pop-up opens in which you specify the bit or bits of the address bus you want to overlap.

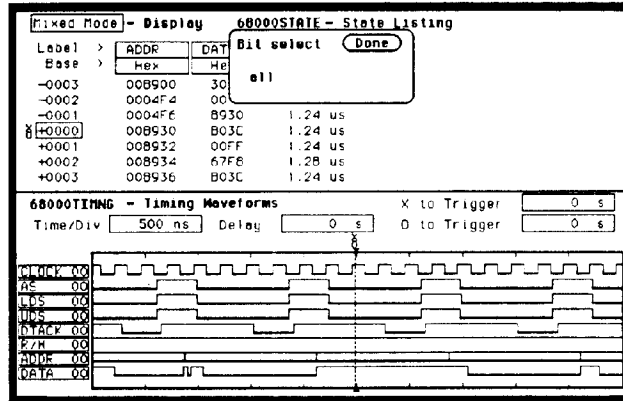

Figure 21-12. Overlapping Timing Waveforms

2. Rotate the KNOB until all is displayed and press SELECT. All the address bits will be overlapped on one line.
3. Repeat step 2 except overlap the data bits.

Finding the Answer

As you look at the overlapping waveforms, you notice there are transitions on the data lines during the read cycle, indicating the data is unstable. You have found the probable cause of the problem in this routine. Additional troubleshooting of the hardware will identify the actual cause.

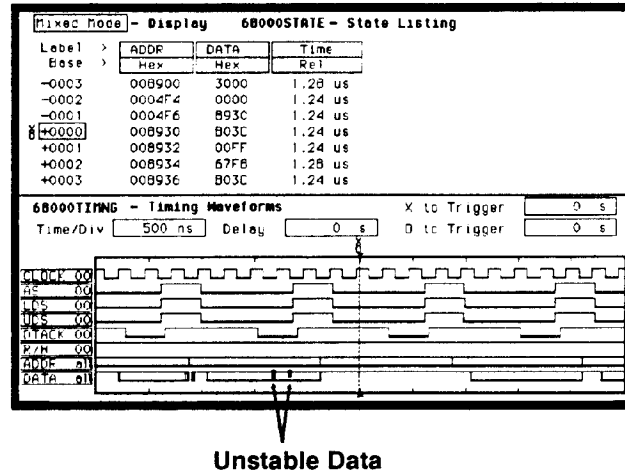

Figure 21-13. Unstable Data

Summary

You have just learned how to use the timing and state analyzers interactively to find a problem that first appeared to be a software problem, but actually was a hardware problem.

You have learned to do the following:

- Trigger one analyzer with the other.
- Time correlate measurement data.
- Interpret the Mixed mode display.
- Overlap timing waveforms.

If you have an HP 1653B, you do not have enough channels to simultaneously capture all the data for a 68000. But, since you probably aren't working with 16-bit microprocessors, this exercise is still valuable because it shows you how to make the same kind of measurement on an eight-bit microprocessor.

The Oscilloscope

Introduction

This chapter introduces the oscilloscope and gives an overview of the main menus that you will use on your oscilloscope. Also included are scope menu maps. The purpose and functions of each menu are explained in detail in the following chapters.

- Chapter 23 explains the Channel Menu.
- Chapter 24 explains the Trigger Menu.
- Chapter 25 explains the Waveforms Menu.
- Chapter 26 explains Mixed Mode Displays.
- Chapter 27 gives you a basic mixed mode measurement example.

An actual signal from the compensation signal output is used throughout most of these chapters to better illustrate how to use the different oscilloscope menus. If you need an introduction to oscilloscopes, refer to *Feeling Comfortable with Digitizing Oscilloscopes*.

The Scope (An Overview)

The oscilloscope in the HP 1652B/1653B Logic Analyzer is a 2 channel, 400 megasample/second, 100 MHz single-shot and repetitive (repetitive single-shot) bandwidth scope. It is turned on/off from the System Configuration menu with the Channel, Trigger and Waveforms menus accessed from front panel keys. The scope can be armed by the analyzer or an external BNC.

Scope Menu Maps

The scope menu maps show you the fields and the available options of each field within the three menus. The menu maps will help you get an overview of each menu as well as provide a quick reference of what each menu contains. Waveform selection is available in all main menus and is shown in the Waveform Selection Menu Map.

The Channel Menu Map

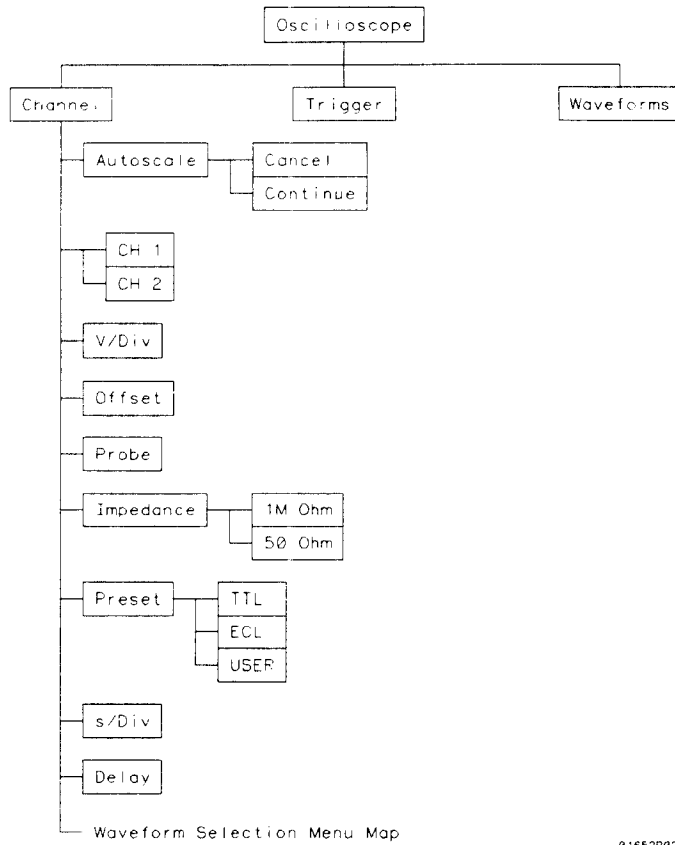

01652B02

The Trigger Menu Map

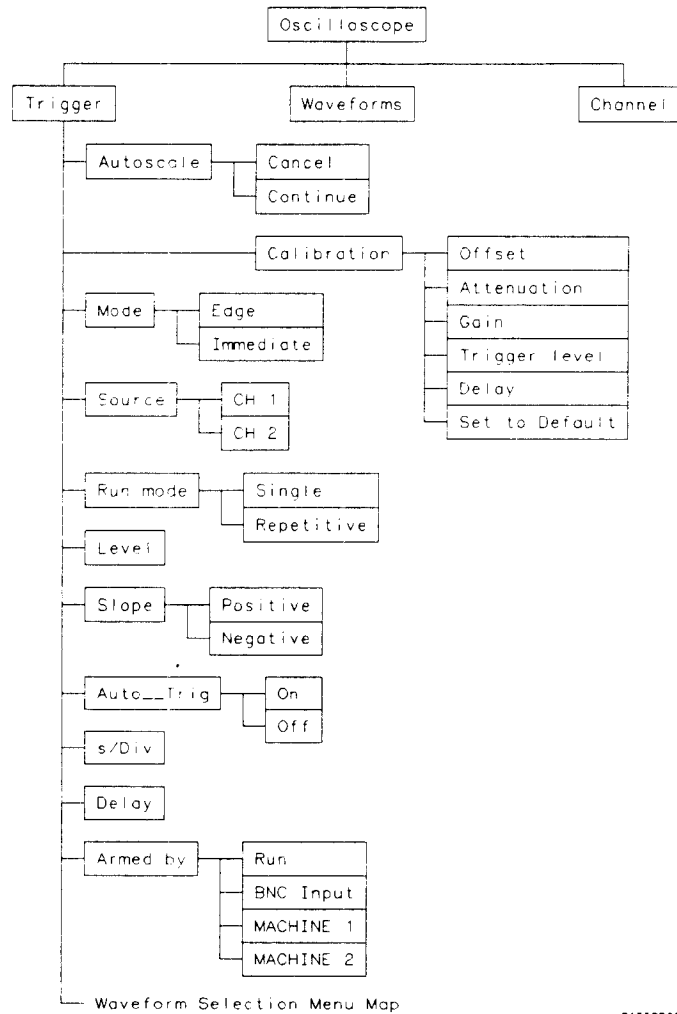

01652B03

The Waveforms Menu Map

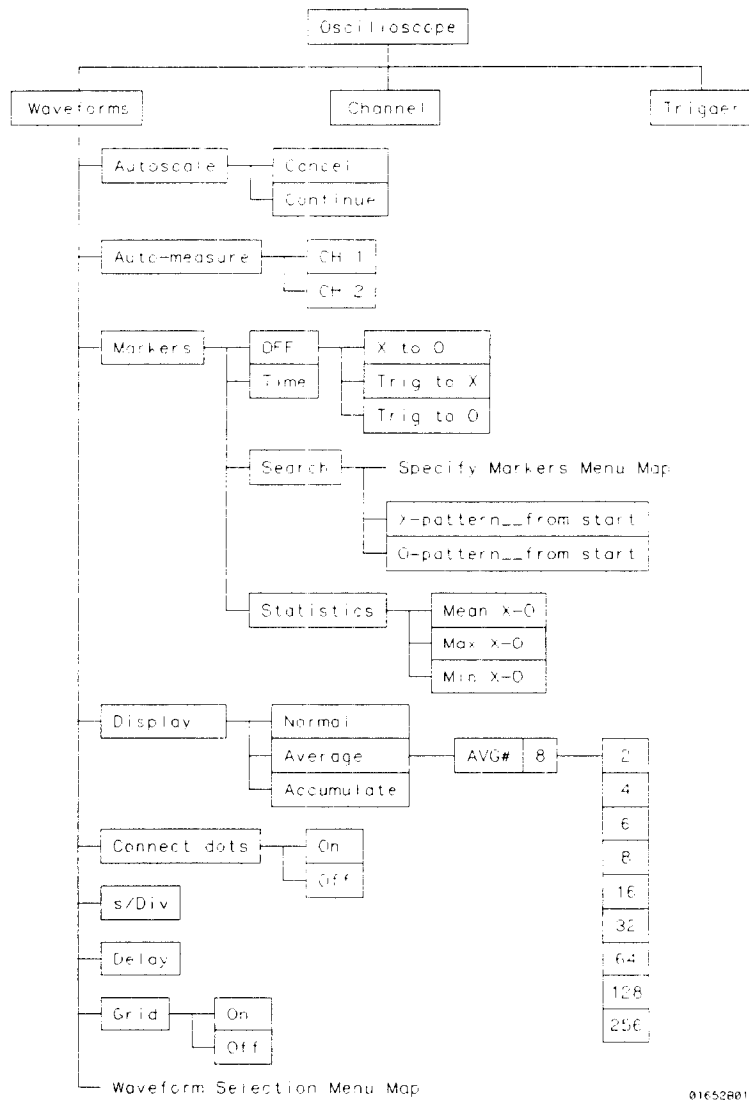

01652B01

Waveform Selection Menu Map

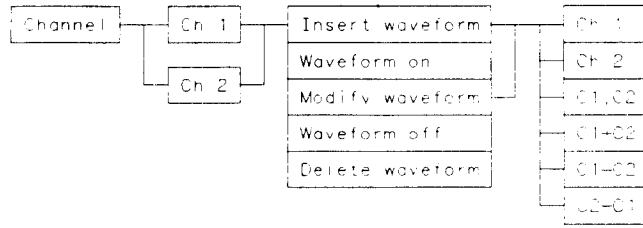

01652B04

Specify Markers Menu Map

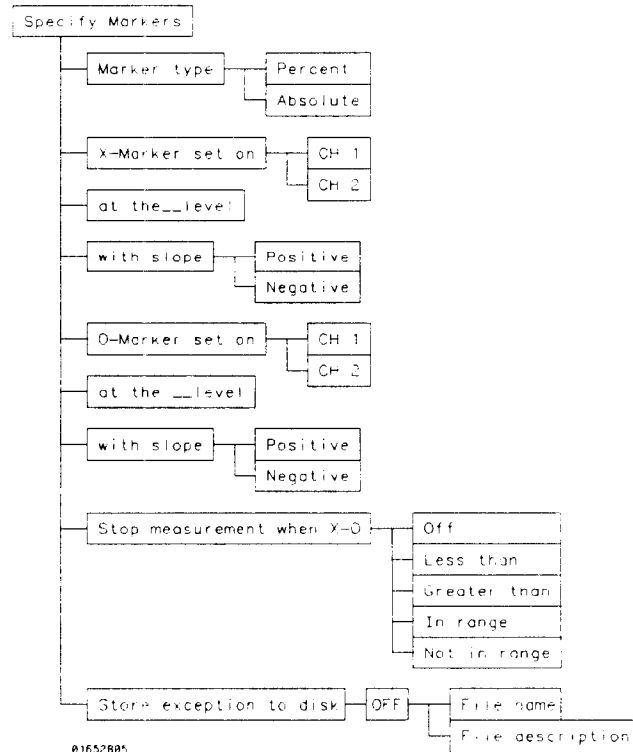

01652B05

Menu Overview

The oscilloscope menus are:

- Channel
 - Timebase Function
 - Autoscale Function
- Trigger
 - Calibration Function
- Waveforms
 - Auto-measure Function
 - Marker Measurement Function

An illustration for each main menu is given at the beginning of each chapter. As new menu fields and pop-up fields appear, a new illustration will be shown. Use these illustrations to help in identifying the field being discussed.

The **Channel menu** (CHAN key) controls the vertical sensitivity, offset, probe attenuation, and input impedance of both input channels. In addition, the timebase functions of seconds/division (s/Div) and delay are controlled in this menu. The s/Div and delay can be controlled in the other main menus as well, but will be defined in the Channel Menu chapter.

Like the timebase functions, the autoscale function is available in all main menus, but is defined in the Channel Menu chapter.

The Trigger menu (TRIG key) controls the selection of trigger modes, input source, level, slope, and auto-trigger. Selection of the arming source and run mode is also controlled in this menu.

Access to the oscilloscope calibration menu is done through this menu. When the calibration field is selected, new menus will appear that guide you through the calibration process. The calibration procedure is found in Appendix D.

The Waveforms menu (DISPLAY key) controls the display mode, connect the dots, and grid on/off. Also included in this menu is the Auto-measure function and Marker measurement criterion set-up.

At power up, the System Configuration menu defaults the oscilloscope to on. All main oscilloscope menus can be selected from the front panel keys.

Channel Menu

Introduction

The Channel menu controls the vertical sensitivity, offset, probe attenuation factor, and input impedance of all input channels, as well as the probe attenuation factor. The Channel menu also allows you to preset vertical sensitivity, offset, and trigger level for ECL and TTL logic levels. The default Channel menu is shown below.

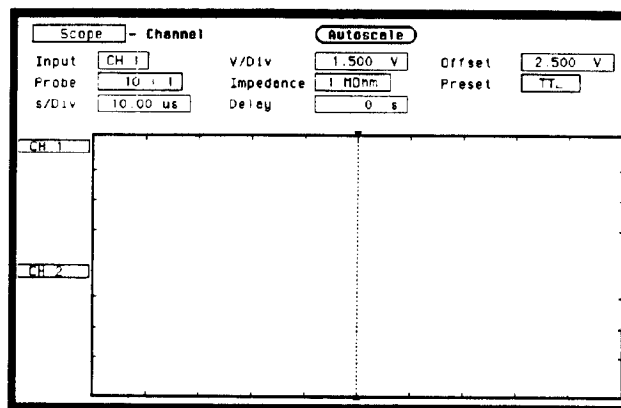

Figure 23-1. Channel Menu

Channel Menu Fields

Input Field The **Input** field is located on the left side of the top row of fields. It selects the input source for the channel parameters displayed on the Channel Specification menu.

The default **Input** field selection is channel 1. When you select the **Input** field, it will toggle from CH 1 to CH 2.

V/Div Field The V/Div field is located in the middle of the top row of fields. It sets the vertical sensitivity of the channel selected in the Input field. Vertical sensitivity determines the size of a waveform displayed on screen and is measured in volts/division. Each waveform display is divided into four vertical divisions. The divisions are marked by small tick marks at the left and right sides of the waveform display.

When the V/Div field is selected, a pop-up will appear which allows the vertical sensitivity to be changed by turning the knob. See upper pop-up in figure 23-2.

As the vertical sensitivity is changed, the signal expands and compresses in both directions vertically from the center of the display. When probe field is set to 10:1, the vertical sensitivity will change in a 1-2-5 sequence from 150 mV/div to 100 V/div.

Vertical sensitivity can also be entered from the keypad. A Numeric Entry pop-up will appear when the first numeric key is touched. See lower pop-up in figure 23-2.

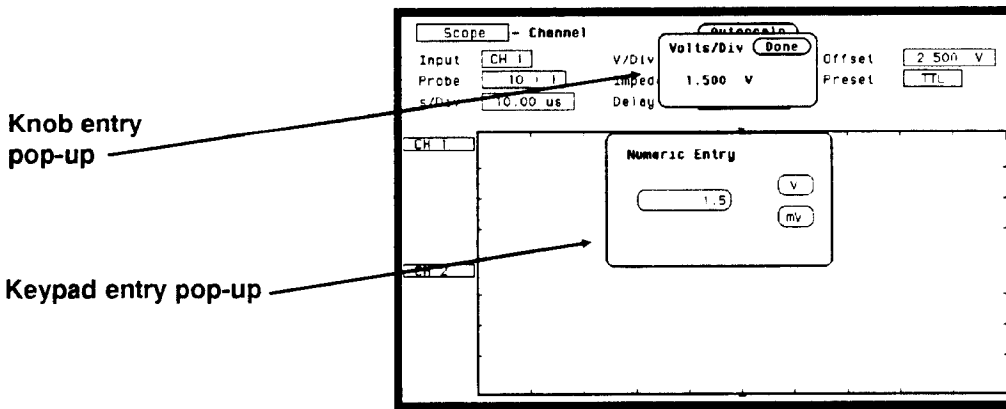

Figure 23-2. V/Div Entry Pop-ups

Any value from 150 mV/div to 100 V/div can be entered from the keypad. The vertical sensitivity value can be set to the two most significant digits. For example, if you entered a value of 154 mV, the value would be rounded to 150 mV.

The default value for the V/Div field is 1.5 V (TTL preset value).



Note

If acquisitions have been stopped, vertical sensitivity changes will not be reflected on the waveform until RUN is touched and the next acquisition is displayed.

Offset Field

The **Offset** field is located on the right side of the top row of fields. Offset is the voltage represented at the center vertical tick mark in the waveform display. Offset is a dc voltage that is added or subtracted from the input signal so that the waveform can be shown centered on the waveform display.

When the Offset field is selected, a pop-up will appear and the offset value of the channel selected in the Input field can be changed by turning the knob. See the upper pop-up in figure 23-3.

As offset is changed, and after a run, the position of the waveform moves up or down on the waveform display. Offset works similar to the vertical position control of an analog oscilloscope, but offset is calibrated.

Valid offset values can also be entered from the keypad. A Numeric Entry pop-up will appear when the first numeric key is touched. See the lower pop-up in figure 23-3.

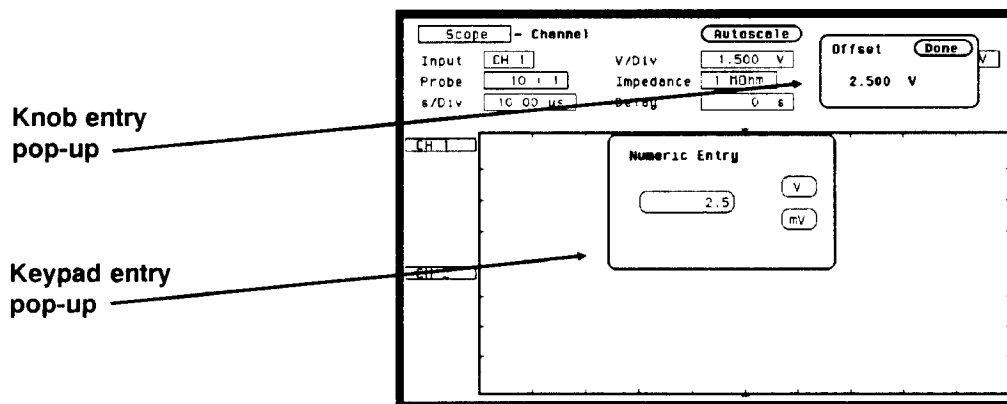

Figure 23-3. Offset Voltage Entry Pop-ups

The default value for the Offset field is 2.5 V (TTL preset value). Offset range and resolution is dependent on vertical sensitivity and input impedance. See table 23-1.



If acquisitions have been stopped, offset changes will not be reflected on the waveform until RUN is touched and the next acquisition is displayed.

Probe Field The **Probe** field is located on the left side of the middle row of fields. It sets the probe attenuation factor for the channel selected. The probe attenuation factor can be set from 1:1 to 1000:1 in increments of 1. When the Probe field is selected, a pop-up will appear and the probe attenuation factor can be changed by turning the knob. See the upper pop-up in figure 23-4.

Probe attenuation can also be entered by using the keypad. An Integer Entry pop-up will appear when the first key is touched. See the lower pop-up in figure 23-4.

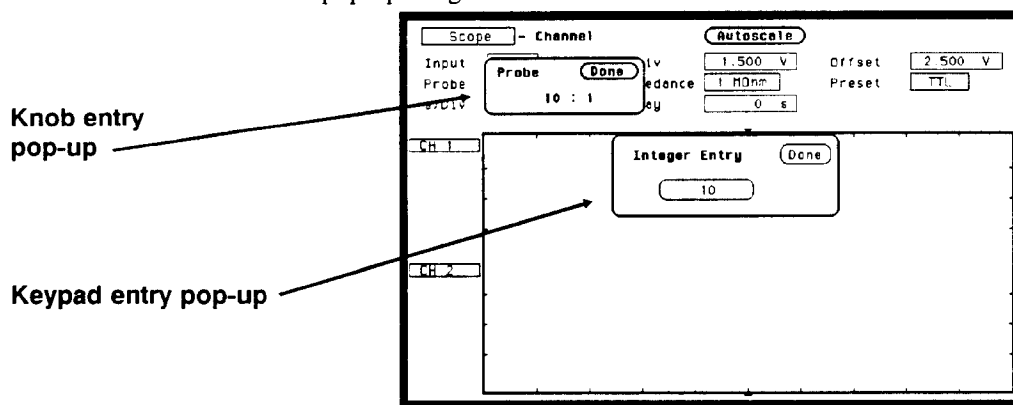

Figure 23-4. Probe Attenuation Entry Pop-ups

When you select a probe attenuation factor, the actual sensitivity at the input does not change; The voltage values used on the display (V/div, offset, marker values, trigger level, automatic measurements) are adjusted to reflect the attenuation factor.

The default value for the Probe field is 10:1 for 10:1 divider probes.

Impedance Field The **Impedance** field is located in the middle of the middle row of fields. It sets the input impedance for the channel selected. When the Impedance field is selected, the input impedance will toggle between 1 M Ω (dc) and 50 Ω (dc). No pop-up keypad is available for this field. The default value for the Impedance field is 1 MOhm.

Preset Field The **Preset** field is located on the right side of the middle row of fields. It automatically sets offset, V/div, and trigger level values to properly display TTL and ECL logic levels.

When you select the Preset field, a pop-up will appear as shown in figure 23-5. Rotate the knob until the proper field is highlighted, then touch the select key.



Figure 23-5. Preset Field Pop-up

When you select TTL or ECL, the following values are set:

PARAMETER	PRESET VALUE	
	ECL	TTL
V/DIV	500MV	1.5V
OFFSET	-1.0V	2.5V
TRIG LEVEL	-1.300V	1.620V

01652M01

Table 23-1. Preset Value

When any of the values listed in table 23-1 are changed from the preset value, the Preset field will change to User defined. If User is selected from the pop-up, no values will be changed.

The default value for the Preset field is TTL.

Waveform Selection

This section will show you how to insert, modify, and delete input channels on the waveform display and how to perform waveform math and overlay functions. Any of these operations can be performed from any of the oscilloscope main menus.

The channel label fields to the left of the waveform display shows the input channels that are being displayed. Figure 23-6 shows the default setting which displays CH 1 and CH 2 selected.

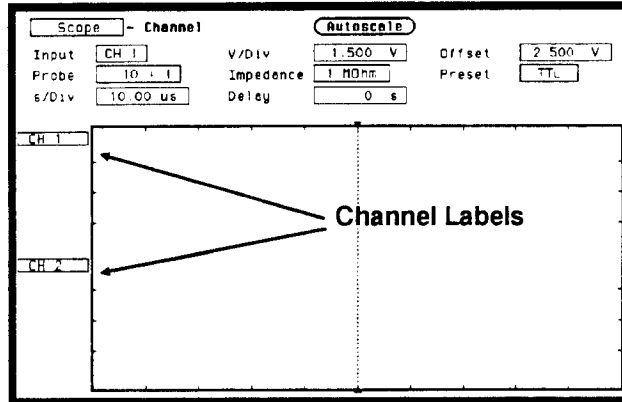

Figure 23-6. Channel Label Fields

Waveform Selection Setup

Set up the oscilloscope as described below. This instrument setup will be used throughout the remainder of this example.

Connecting the Equipment

Connect a BNC tee adapter and BNC cables to the oscilloscope as shown below.

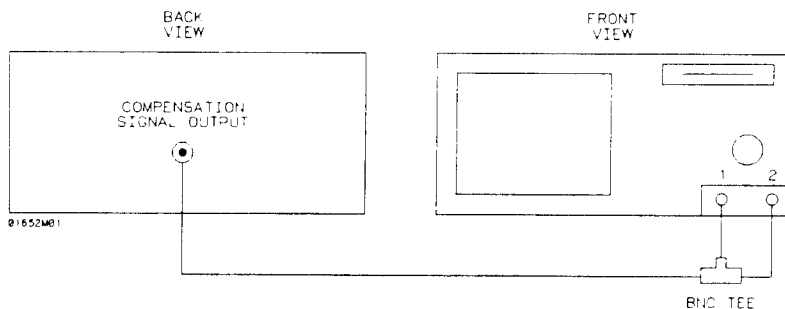

Figure 23-7. Compensation Signal Hookup

Setting Up the Oscilloscope

1. Turn the power on to the instrument.
2. From the System Configuration menu, turn the oscilloscope on and all analyzers off.
3. Touch CHAN key. From the default oscilloscope Channel menu, make the following changes:
 - CH 1 Probe field to 1:1
 - CH 1 Impedance field to 50 Ohms
 - CH 2 Probe field to 1:1
 - CH 2 Impedance field to 50 Ohms
4. Select Autoscale and set to Continue.
5. Touch the TRIG key to display the Trigger menu.

6. Select the **Run mode** field and toggle to **Repetitive**.
7. Select the **Waveforms** menu and toggle **Connect dots** field to **On**.
The displayed waveforms should now look like figure 23-8.

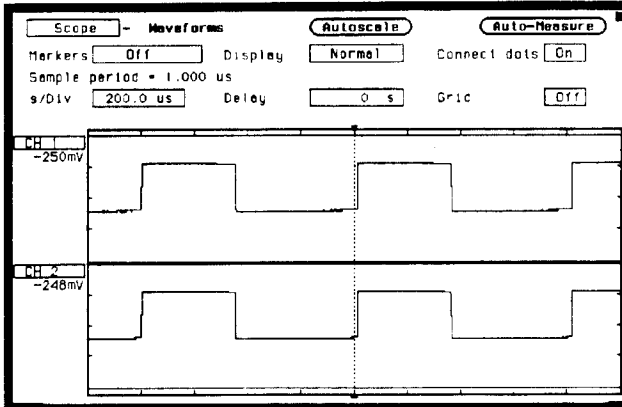

Figure 23-8. Compensation Signal Waveforms

Turning the Waveforms On/Off

The waveform selection defaults to Waveform on for channel 1 and channel 2.

1. Select the CH 1 input label. A waveform selection pop-up appears as shown in figure 23-9.

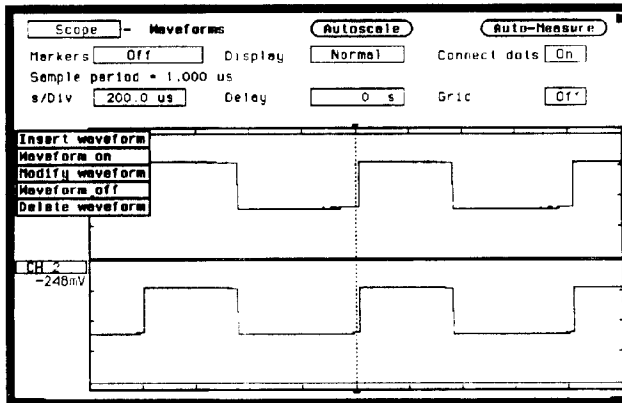

Figure 23-9. Waveform Selection Pop-up menu

2. With Waveform on, the channel 1 signal will be displayed in the waveform display. Select **Waveform off**. Channel 1 signal is now gone, and the channel label has changed to **-off-**. See figure 23-10.

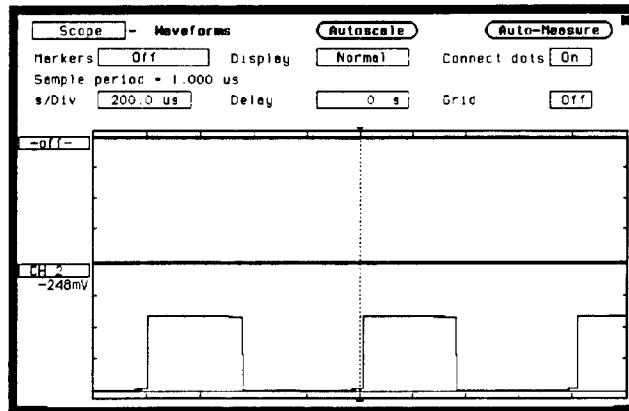

Figure 23-10. Channel 1 Turned Off

3. To turn channel 1 waveform back on, select the channel label field, then select **Waveform on**.

Insert/Delete Waveforms

When a signal is inserted into the waveform display, its label field and waveform will always be displayed directly below the highlighted label and corresponding waveform.

1. Select **CH 1** label field, then select **Insert waveform**. A channel mode pop-up will appear. See figure 23-11.

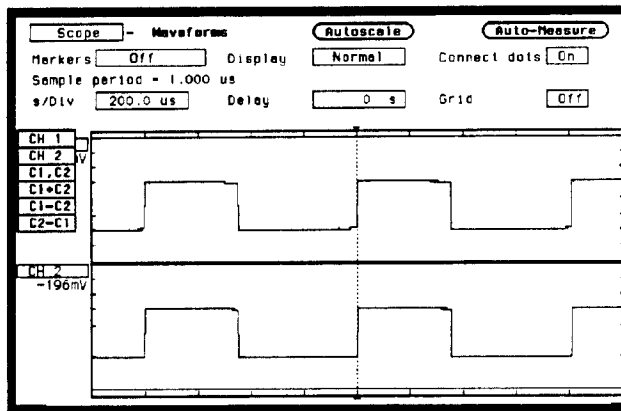

Figure 23-11. Channel Mode Pop-up

2. Select **CH 2**. Notice that the second CH 2 was inserted directly below CH 1.
3. To delete CH 2 from the channel label list, select **CH 2**.
4. Select **Delete waveform**. CH 2 is now removed and you are back to the start.

Modify Waveforms

When you modify a waveform, you select the channel label to be modified and replace it with a selection from the channel mode pop-up.

1. Select **CH 1** label field, then select **Modify waveform**.
2. Select **CH 2** from the channel mode pop-up, then touch the **RUN** key. Notice that CH 1 has been replaced with CH 2. Channel 2 is now being displayed twice.
3. Select **CH 2** label field (the same one just modified), then select **Modify waveform**.
4. Select **CH 1** from the channel mode pop-up, then touch the **RUN** key. Now you are back to the start.

Overlay (C1,C2) What we have been displaying so far in this section are examples using just single channels. These examples display a single input channel in each waveform display.

Suppose you wanted to take the signal from CH 1 and compare it to the signal from CH 2. The easiest way to do this would be to put both waveforms on the same waveform display, or overlay the waveforms.

1. Select **CH 1**, then select **Modify waveform**. Select **C1,C2**, then touch the **RUN** key. CH 2 is now overlaid on CH 1 in the top waveform display.
2. Select the **s/Div** field and change the sweep speed to 5 ns/div. This will allow us to see the overlaid waveforms easier. The display should now look like the figure below.

Note 

To get a better display of the two waveforms overlaid, use an extra long cable on one of the inputs. This will delay one waveform.

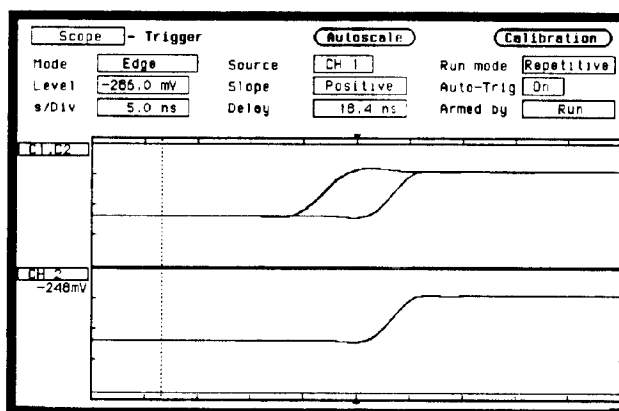

Figure 23-12. Overlay Waveform Display

Waveform Math
(C1 + C2), (C1-C2)

Suppose you wanted to take the signal from CH 2 and add it to or subtract it from the signal from CH 1. Let's try subtracting CH 2 from CH 1.

1. Select C1,C2 label field, then select **Modify waveform**.
2. Select C1-C2 field. With the s/Div still set at 5 ns, the waveform display should look like the figure below.

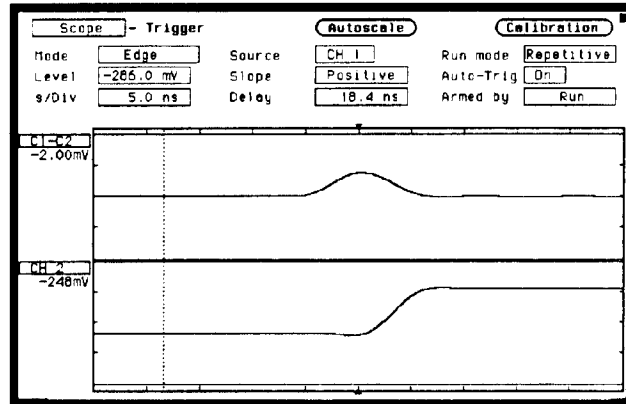

Figure 23-13. C1-C2 Waveform Display

Timebase Functions

The *s/Div* and Delay timebase functions control the horizontal display on the oscilloscope. The **Delay** and *s/Div* fields are located in the bottom row of fields and are displayed on all oscilloscope main menus.

Instrument Setup

The instrument should already be set up from the previous exercise. If you need to reset the menu fields, refer to that exercise or select the **Autoscale** field and set to **Continue**. Your screen should look like the figure below.

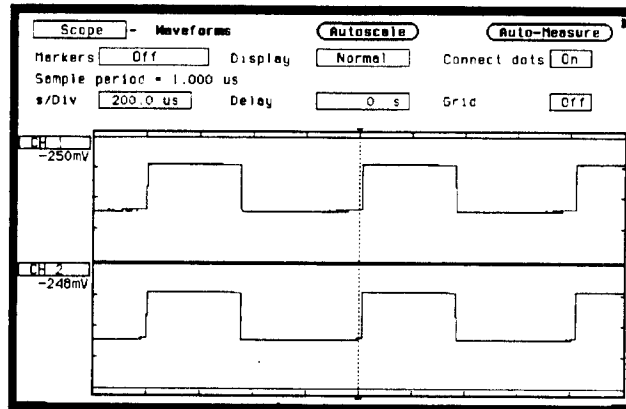

Figure 23-14. Compensation Signal Waveform

s/Div Field The s/Div field sets the sweep speed or time scale on the horizontal axis of the display and is measured in seconds/division. The display is divided into 10 horizontal divisions. The divisions are marked by small tick marks at the top and bottom of the waveform display.

When the s/Div field is selected, a pop-up will appear and the sweep speed of the channel selected in the Input field can be changed by turning the knob. See the upper pop-up in figure 23-15.

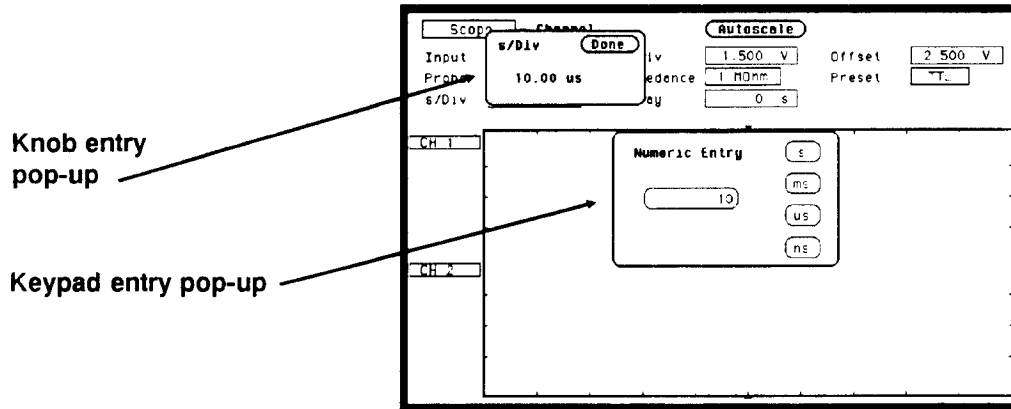

Figure 23-15. s/Div Entry Pop-ups

As the sweep speed is changed, the signal expands and compresses in both directions from the center of the display. As you turn the knob, the sweep speed changes in a 1-2-5 sequence from 5 ns/Div to 5 s/Div.

Sweep speed can also be entered from the Numeric Entry pop-up. The pop-up will appear when the first numeric key is touched. See the lower pop-up in figure 23-15.

Any value from 5 ns/Div to 5 s/Div can be enter from the keypad. Sweep speed can be set to three-digit resolution. For example, if you entered a value of 15.45 ns, the value would be rounded up to 15.5 ns.

At sweep speeds of 100 ms/div and slower, the time to acquire the 2048 sample points for acquisition memory is greater than 1 second. At these sweep speeds the screen will display "Scope waiting for prestore" when acquiring the 2048 sample points prior to the trigger point or "Scope waiting for poststore" when acquiring the 2048 sample points after the trigger point. These advisories let you know the oscilloscope is still actively acquiring data.

The default value for the s/Div field is 10 μ s.

Zoom (Acquisition Stopped)

If acquisitions have been stopped, the oscilloscope uses the 2048 sample points stored in acquisition memory to display the new data on screen when the sweep speed is changed. This function would normally be used to zoom in or zoom out on a waveform acquired in Single (single-shot) mode. Zooming either expands or compresses the waveform horizontally and is changed by adjusting the s/Div field.

Zoom Example

Select the s/Div field and turn the knob to set the sweep speed to 200 μ s/Div, then touch the **Stop Key** to stop acquisitions. Now turn the knob to change the sweep speed and notice how the acquired waveform expands and compresses.

Normally 500 points of the 2k waveform record is displayed on screen. Change the sweep speed to 500 us/div. Now all 2k of the waveform record is compressed and displayed on screen. See figure 23-16.

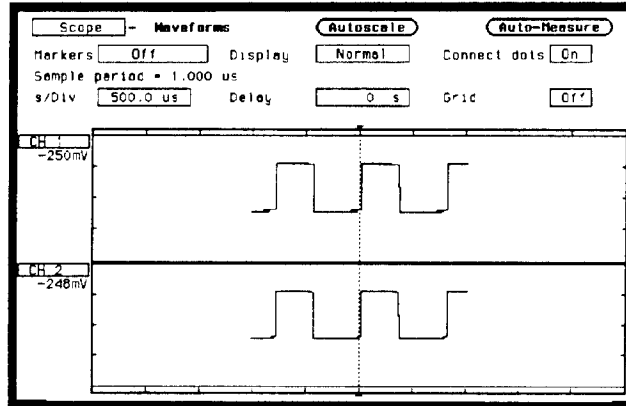

Figure 23-16. Compressed Waveform

Now change the sweep speed to 2 us/Div. At 200 us/Div, 500 points were displayed; at 2 us/Div, only 20 points are displayed. When the waveform is expanded, the oscilloscope uses a reconstruction filter to fill in the waveform points to provide a more useable display. When used in conjunction with scrolling (see "Delay Field" paragraph), zooming is very useful in displaying single-shot waveforms.

Delay Field

Delay time is the time offset before or after the trigger point on the waveform and is always measured from the trigger point to the center of the screen. The dotted line at the center of the display is the trigger point. When delay time is zero, the trigger point is at the center of the screen.

When the Delay field is selected, a pop-up will appear and the delay time can be changed by turning the knob. Remember that the trigger point is always delay time zero and is marked by the dotted line. When the trigger point moves to the right side of the screen, the delay time is negative. This means that what you are viewing at center screen is before the trigger point and is referred to as negative time.

When the trigger point is moved to the left side of the screen, the delay time is positive and what you are viewing at center screen is after the trigger point.

Delay time resolution is equal to 2% of the sweep speed setting when using the knob. When using the pop-up keypad, resolution is 100 ps at sweep speeds of 99.9 ns/Div and faster, and can be set to 4-digit resolution at sweep speeds of 100 ns/div and slower.

Scrolling (Acquisition Stopped)

If acquisitions have been stopped, the Delay field controls the portion of the acquisition memory displayed on screen.

When acquisition has been stopped:

Pre-trigger delay range = delay time setting - (1024 X sample rate)
Post-trigger delay range = delay time setting + (1024 X sample rate)

This means that one-half of data stored in acquisition memory is before the delay time setting and one-half of the data in memory is after the delay time setting.

This function would normally be used to scroll through a waveform acquired in Single (single-shot) mode. Scrolling allows you to view the entire waveform record by adjusting the Delay field.

Scroll Example

Select the *s/Div* field and turn the knob to set the sweep speed to 200 us/div, then touch the Stop key to stop acquisitions. Select the **Delay** field and turn the knob to change delay time to approximately -1 ms. As shown in figure 23-17, you are now looking at the beginning of the waveform record. You can now scroll through the entire 2k waveform record, both before and after the trigger point. When used in conjunction with zooming (see "*s/Div* Field" paragraph), scrolling is very useful in displaying single-shot waveforms.

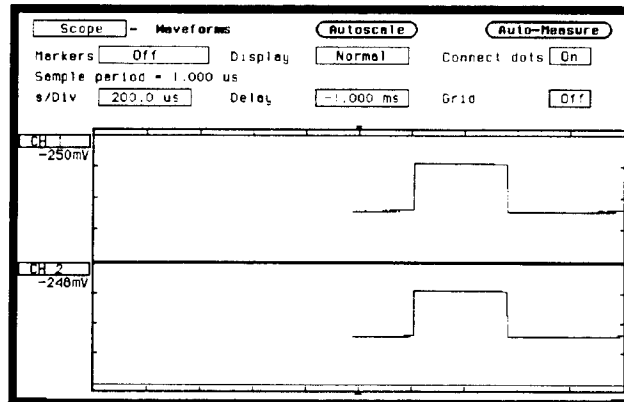

Figure 23-17. Scroll Beginning of Waveform

Autoscale Field

The **Autoscale** field is located in the middle of the top row of fields in all scope main menus except when the Markers field is set to Statistics. When the Autoscale field is selected, a pop-up appears allowing you to cancel or continue the autoscale. See figure 23-18.

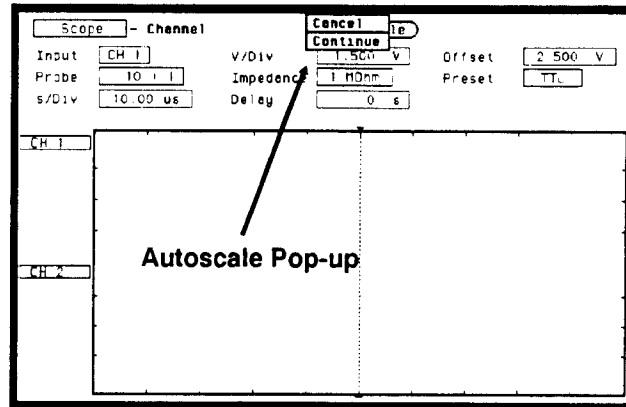

Figure 23-18. Autoscale Pop-up

If you have inadvertently selected autoscale or wish to abort the autoscale, select Cancel. If the Continue field is touched, the autoscale function is started and the advisory Autoscale is in progress is displayed. The oscilloscope automatically sets V/Div (vertical sensitivity), channel Offset, s/Div (sweep speed), and trigger Level so that the input signals are displayed on screen. The oscilloscope checks all vertical inputs and looks for the trigger on channel 1. The following fields are changed when autoscale is complete:

Channel menu

V/Div	scaled
Offset	scaled

Trigger Menu

Mode	Edge
Source	set to lowest number input with signal present
Level	scaled
Slope	positive

Any menu

s/Div
Delay

When a Signal is Found

If a signal is found on any of the vertical inputs, the oscilloscope determines the frequency of the signals and automatically scales the vertical sensitivity, offset, sweep speed, and trigger level to display the waveform on screen. The oscilloscope will normally display between 1 and 3 complete cycles of the waveform.

If a signal is present at more than one input, the trigger source is always assigned to the signal input on channel 1. This input is also used to scale the sweep speed. If only one vertical input has a signal present, that signal is the trigger source.

If No Signal is Found

If no signal is found on any of the vertical inputs, the oscilloscope displays the advisory **No signal found**, then displays **Auto Triggered**, and the oscilloscope is placed in an auto-trigger mode. The auto-trigger mode allows the oscilloscope to auto-sweep and display a baseline anytime a trigger signal is not present.

Trigger Menu

Introduction

The Trigger menu controls the selection of trigger modes for the oscilloscope. The Trigger menu has two modes:

- Edge
- Immediate

The default Trigger menu is shown in figure 24-1.

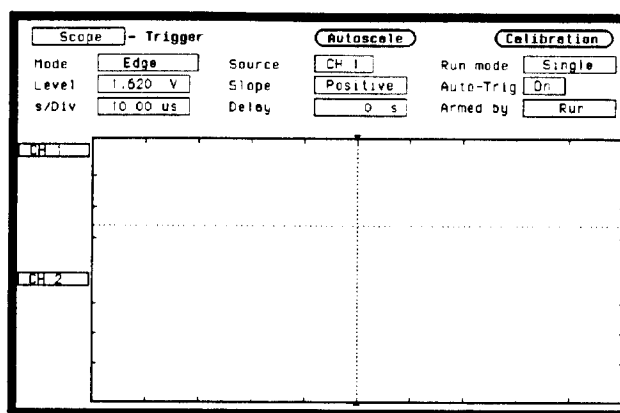

Figure 24-1. Trigger Specification Menu

Calibration

When the Calibration field is selected, a pop-up will appear showing the calibration menu. Information on when and how to calibrate the oscilloscope is found in Appendix D.

Trigger Point Marker

The trigger point marker, is the dotted vertical line at the center of the waveform display. This dotted vertical line, points to the place on the waveform where the trigger source waveform or trigger condition intersects. This point of intersection is where timebase delay is referenced. This point represents a delay time of zero seconds. See figure 24-2.

If delay time is set to greater than 5 times the sweep speed, the trigger marker will be moved off screen.

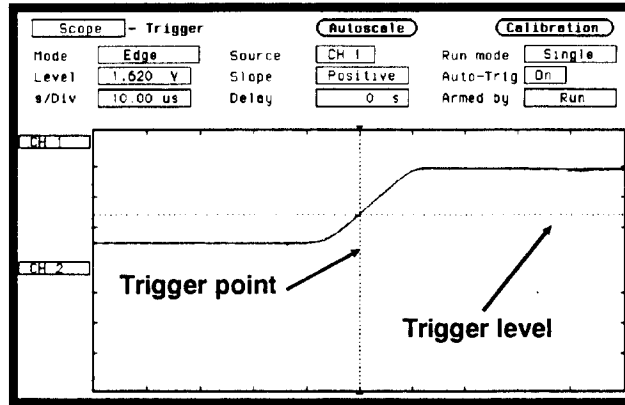

Figure 24-2. Trigger Point

Mode Field

The Mode field is located on the left side of the top row of fields and selects the trigger mode for the oscilloscope. When you select the Mode field, it will toggle between **Edge** and **Immediate**.

The default selection for the Mode field is Edge.

Immediate Trigger Mode

Immediate trigger mode causes the oscilloscope to trigger by itself after the arming requirements are met. This can be used when a logic analyzer arms the scope or another instrument arms the scope via the BNC connector. The default Immediate trigger menu is shown in figure 24-3.

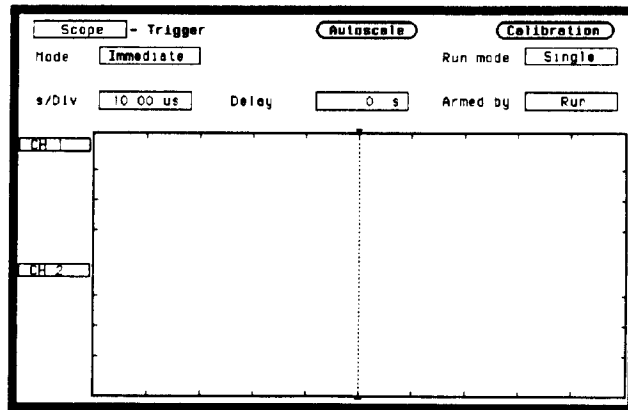

Figure 24-3. Immediate Trigger Mode Default Menu

Armed by Field

The Armed by field is located on the right side of the bottom row of fields. When selected, a pop-up will appear that is used to set any arming requirements. See figure 24-4.

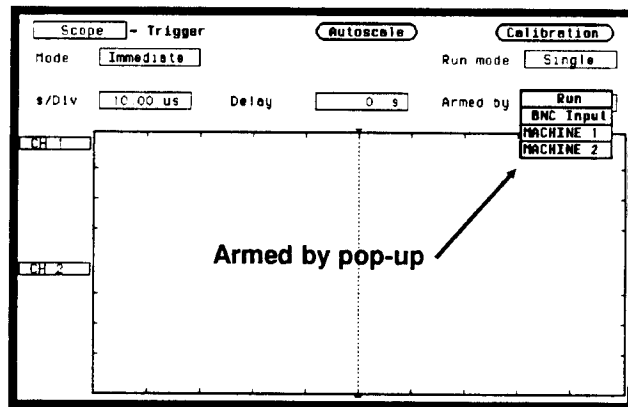

Figure 24-4. Arming Selection Pop-up

Run. If Run is selected in the Armed by field, the oscilloscope will be in the free-run mode and the waveform display will not be synchronized to a trigger point.

BNC Input. If BNC Input is selected, and the oscilloscope is in the trigger Immediate mode, it triggers and synchronizes itself as soon as it is armed by a signal from the External Trigger Input on the rear panel.

Machine 1 and 2. If Machine 1 or Machine 2 is selected, and the oscilloscope is in the trigger Immediate mode, it triggers and synchronizes itself as soon as it is armed by an internal signal from the appropriate analyzer.

The default selection for the Armed by field is Run.

Edge Trigger Mode

Edge trigger is the type of triggering found in all oscilloscopes. In edge trigger mode the oscilloscope triggers at a specified voltage level on a rising or falling edge of one of the input channels.

In this mode you can specify which input is the trigger source, set a trigger level voltage, and specify which edge to trigger on.

Source Field

The trigger Source field is located in the middle of the top row of fields and when selected, will toggle between channels 1 and 2.

The default selection for the Source field is channel 1.

Level Field

The trigger voltage Level field is located on the left side of the middle row of fields and is used to set the voltage level at which the trigger source waveform crosses the trigger marker. When the Level field is selected, a pop-up will appear which allows the trigger level to be changed by turning the knob. See the upper pop-up in figure 24-5.

When the trigger level is changed, the waveform moves on the display to maintain the trigger point (where waveform edge crosses the trigger level line). If the trigger level is set above or below the waveform, trigger is lost and the waveform display will be unsynchronized.

The trigger level, when set with the knob, can be any voltage value contained within the waveform display window in increments of 1% of full scale vertical voltage range ($V/Div \times 4$). For example, if full scale voltage range were 500 mV, trigger level could be set in increments of 20 mV.

Trigger level can also be entered from the keypad. A Numeric Entry pop-up will appear when the first key is touched. See the lower pop-up in figure 24-5.

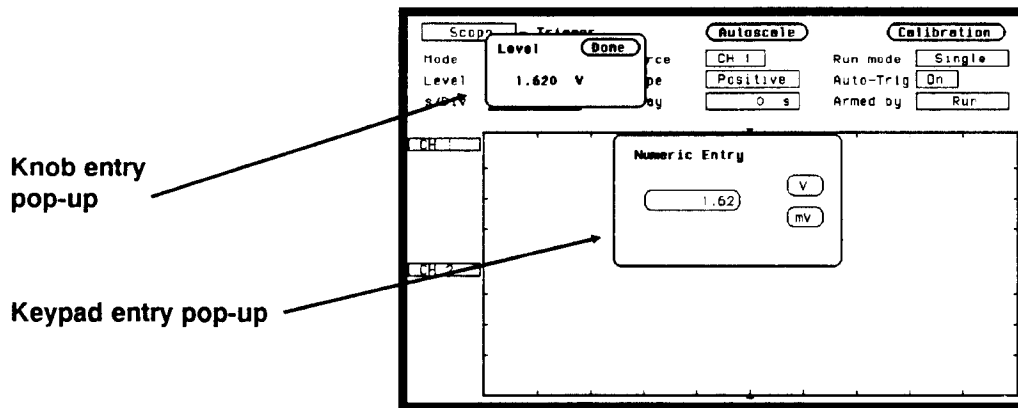

Figure 24-5. Trigger Level Entry Pop-ups

Since the trigger level range is limited by the voltage values set for the waveform window, the voltage level range can be easily determined. Turn the knob in both directions until the Level field reads minimum and maximum voltage. These voltage values are the trigger level limits of the waveform window.

The default value for the Level field is 1.62 V (TTL preset value).

Slope Field

The Slope field is located in the middle of the middle row of fields. It selects which edge of the trigger source waveform the oscilloscope will trigger on. When Slope is selected, it will toggle between positive and negative.

The default selection for the Slope field is Positive.

Auto-Trig Field

The Auto-Trig field is located on the right side in the middle row of fields. It lets you specify whether or not the acquisitions should wait for the specified trigger condition to occur. When the Auto-Trig field is touched, the field will toggle between On and Off.

On. When auto-trigger is set to on, the oscilloscope waits for approximately 1 sec. for a trigger to occur. If a trigger does not occur within that time, whatever is in the acquisition memory is displayed and "Auto triggered" is displayed:

- if no signal is on the input, the oscilloscope will display a baseline.
- if there is a signal but the specified trigger condition has not been met within 1 sec, the waveform display will not be synchronized to a trigger point.

Off. When auto-trigger is set to off, the oscilloscope waits until a trigger is received before the waveform display is updated. If a trigger does not occur, the screen is not updated and "Waiting for Trigger" is displayed.

The default selection for the Auto-Trig field is On.

Run mode Field

The Run mode field is located on the right side of the top row of fields and is displayed only when in the Trigger menu. This field controls whether the oscilloscope performs a single acquisition or multiple acquisitions. Single mode acquires a waveform on a single acquisition and then stops running. Repetitive mode acquires a waveform a multiple number of times and rebuilds the display after each acquisition. Repetitive mode keeps running until the STOP key is pressed. When powered on, the oscilloscope defaults to the Single mode. There is no pop-up for this field. When selected, it simply toggles between Single and Repetitive.

Single Mode Run. After the Run mode field is set to Single, you start the oscilloscope running in the single-acquisition mode by pressing the RUN key on the front panel. In this mode, the oscilloscope makes a single acquisition, displays the results, then waits until the RUN key is touched again before making another acquisition.

Repetitive Mode Run. After the Run mode field is set to Repetitive, you start the oscilloscope running in the Repetitive (repetitive single-shot) mode by pressing the RUN key on the front panel. In this mode, the display is rebuilt each time a new acquisition is made. When you want to stop making repetitive acquisitions, touch the STOP key on the front panel. To resume making repetitive acquisitions, touch the RUN key again.



Before a repetitive run can be executed, all analyzers must either be turned off, or they must have acquired data.

Waveforms Menu

Introduction

The Waveforms menu controls how the oscilloscope displays the waveforms. The waveforms may be displayed in normal, averaged, or accumulated mode. This menu also controls the connect-the-dots display feature. The default Display menu is shown in figure 25-1.

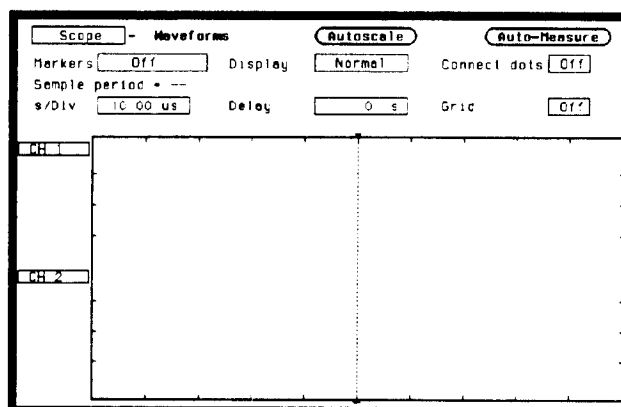

Figure 25-1. Waveforms Display Menu

Scope Field

The Scope field located in the upper left corner of the menu is used for accessing the System Configuration menu, any assigned analyzers, and the mixed mode display operation. More information on mixed mode displays and the system configuration menu is found in the appropriate chapters.

Auto-Measure Field

Automatic parametric measurements are functions built into the digitizing oscilloscope that make parametric measurements on a displayed waveform.

The Auto-measure field is located in the upper right corner of the Waveforms menu. When the Auto-measure field is selected, a pop-up will appear that lists the parameters measured for the channel selected. See Figure 25-2.

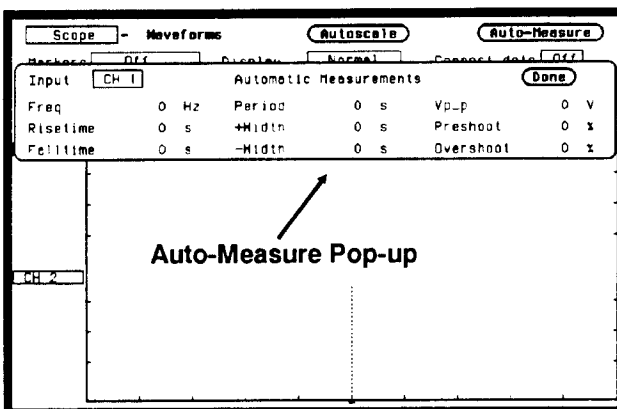

Figure 25-2. Automatic Measurement Pop-up

The channel field, which is located in the upper right corner of the pop-up, will toggle between channel 1 and channel 2 when selected. The default selection for this field is channel 1.

There are nine automatic measurements made from the data that is displayed in the waveform display:

- Period
- Risetime
- Falltime
- Frequency
- + Width
- Width
- Vp_p
- Preshoot
- Overshoot

Keep the following in mind when making measurements.

- At least one full cycle of the waveform with at least two like edges must be displayed for Period and Freq measurements.

- A complete positive pulse must be displayed to make a + Width measurement, and a complete negative pulse must be displayed to make a -Width measurement.
- Risetime, Falltime, Preshoot, and Overshoot measurements will be more accurate if you expand the edge of the waveform by selecting a faster sweep speed.

Top and Base Voltages

All measurements except Vp-p are calculated using the Vtop (100% voltage) and Vbase (0% voltage) levels of the displayed waveform. The Vtop and Vbase levels are determined from an occurrence density histogram of the data points displayed on screen.

The digitizing oscilloscope displays 6-bit vertical voltage resolution. This means the vertical display is divided up into 2^6 voltage levels. Each of these 64 levels is called a quantization level. Each waveform has a minimum of 500 data points displayed horizontally on screen. Each of these data point sets have one quantization level assigned to it. The histogram is calculated by adding the number of occurrences of each quantization level of the displayed data point sets on the displayed waveform.

The quantization level with the greatest number of occurrences in the top half of the waveform corresponds to the Vtop level. The quantization level with the greatest number of occurrences in the bottom half of the waveform corresponds to the Vbase level.

If Vtop and Vbase do not contain at least 5% of the minimum (500) data points displayed on screen, Vtop defaults to the maximum voltage (Vmaximum) and Vbase defaults to the minimum voltage (Vminimum) found on the display. An example of this case would be measurements made on sine or triangle waves.

From this information the instrument can determine the 10, 50, and 90% points, which are used in most automatic measurements. The Vtop or Vbase of the waveform is not necessarily the maximum or minimum voltage present on the waveform. If a pulse has a slight amount of overshoot, it would be wrong to select the highest peak of the waveform as the top since the waveform normally rests below the perturbation.

Automatic Measurement Example

To demonstrate how to make automatic measurements, set up the oscilloscope as described below. This setup will be used throughout the remainder of this section.

Connecting the Equipment

Connect a BNC tee adapter and BNC cables to the oscilloscope as shown in figure 25-3.

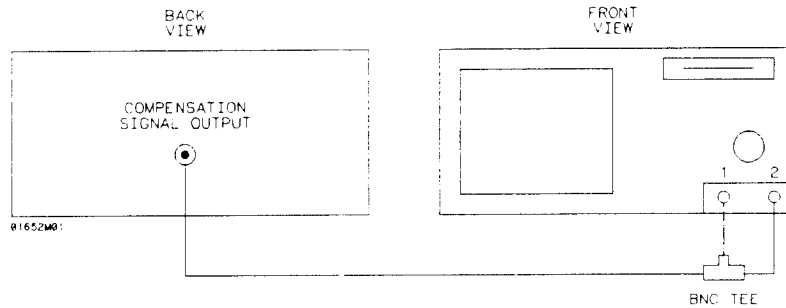

Figure 25-3. Equipment Setup

Setting Up the Oscilloscope

1. Turn the instrument on.
2. From the System Configuration menu, turn the oscilloscope on and all analyzers off.
3. Touch CHAN key and from the default Channel Specification menu, make the following changes:
 - Input CH 1 Probe field to 1:1
 - Input CH 1 Impedance field to 50 Ohms
 - Input CH 2 Probe field to 1:1
 - Input CH 2 Impedance field to 50 Ohms
4. Select **Autoscale**, then select **Continue**.

5. Touch the TRIG key and set the Run mode to Repetitive.
6. Select the Waveforms menu and toggle Connect dots field to on. The displayed waveform should now look like figure 25-4.

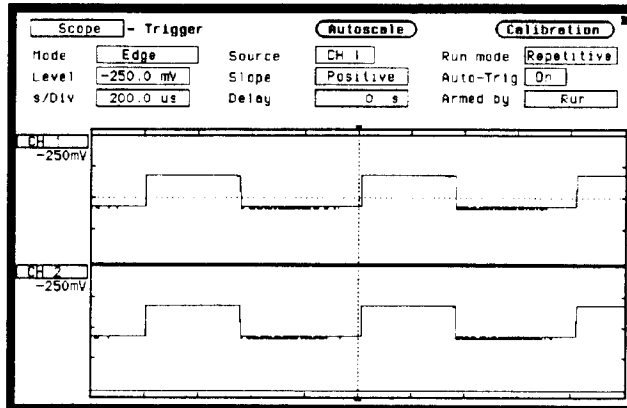

Figure 25-4. Autoscaled Waveform

Rise Time Measurement

Risetime is measured on the positive-going edge of the waveform and is the time it takes the waveform to transition between the 10% voltage point and the 90% voltage point.

1. Select the s/Div field and change the sweep speed to 5 ns/div. The expanded waveform should look like the figure below.

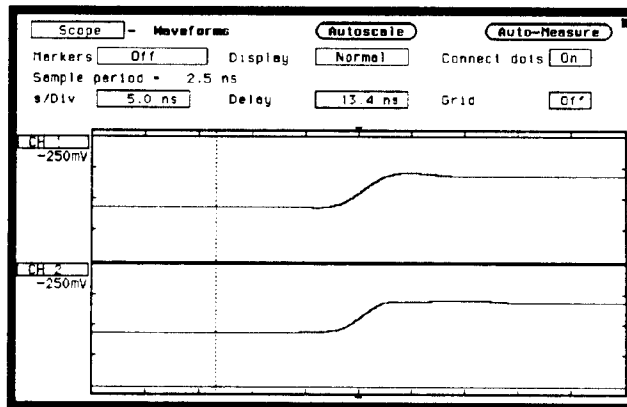

Figure 25-5. Expanded Waveform

Expanding the edge on the waveform will give more accurate results because more data points on the rising edge will be displayed.

2. From the Waveforms menu select the **Auto-Measure** field. The Risetime value is displayed in the Automatic Measurements listing pop-up.

Notice that Period, Falltime, Freq, + Width, and -Width listings are blank. Because only the rising edge of the waveform is displayed, there is insufficient data at this time to make these measurements.

3. Select **Done**. You are now back to the Waveform menu.

Fall Time Measurement

Fall time is measured on the negative-going edge of the waveform and is the time it takes the waveform to transition between the 90% voltage point and 10% voltage point. You are currently displaying the positive-going edge of the waveform, so you need to change it to the negative-going edge.

4. Touch the TRIG key and toggle the **Slope** field in the Trigger Specification menu to Negative. Notice the negative-going edge of the waveform is now displayed as shown in figure 25-6.
5. Touch the Display key and select the **Auto-Measure** field in the Waveforms menu. The Falltime value is now displayed in the Automatic Measurement listing pop-up.

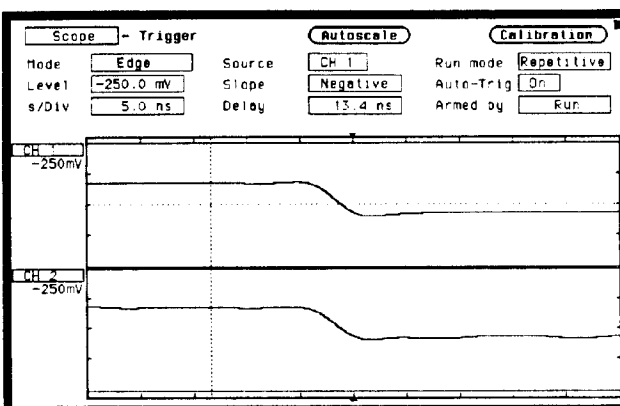

Figure 25-6. Negative Edge Of Waveform

6. Now measure the falltime on CH 2. Select the **Input** field in the Automatic Measurement listing pop-up and toggle to CH 2.
7. All readings in the Automatic Measurement listing pop-up are now for CH2. Falltime is now being measured on CH 2.

Vp-p Measurement

The peak-to-peak voltage measurement uses the maximum voltage and the minimum voltage values found in the data displayed on screen.

$$\mathbf{Vp-p = Vmaximum - Vminimum}$$

8. Notice the Vp_p measurement displayed in the Automatic Measurements listing pop-up. This reading is for the channel currently selected.
9. Select **Done** to exit the Automatic Measurements listing pop-up.

Period and Frequency Measurements

Period and Freq (frequency) measurements are made using the first two like edges of an input displayed on screen. At least one full cycle of the waveform must be displayed to make the measurements. If a full cycle is not present, the Period and Freq measurements in the auto-measure field will be blank. Period and Freq are measured using the time (t) at the 50% level of the edges.

If the first edge on the display is rising then:

$$\text{Period} = t_{\text{rising edge 2}} - t_{\text{rising edge 1}}$$
$$\text{Freq} = 1/(t_{\text{rising edge 2}} - t_{\text{rising edge 1}})$$

If the first edge on the display is falling then:

$$\text{Period} = t_{\text{falling edge 2}} - t_{\text{falling edge 1}}$$
$$\text{Freq} = 1/(t_{\text{falling edge 2}} - t_{\text{falling edge 1}})$$

Re-scale the waveform to display at least one full cycle of the waveform, then make a Period and Freq measurement on CH 1.

1. From the Waveform menu, select s/Div and change s/Div field to 100 μs to display only one full cycle of the waveform. See figure 25-7.
2. Select **Auto-Measure** and notice the Period and Freq measurements displayed in the Automatic Measurement listing pop-up.

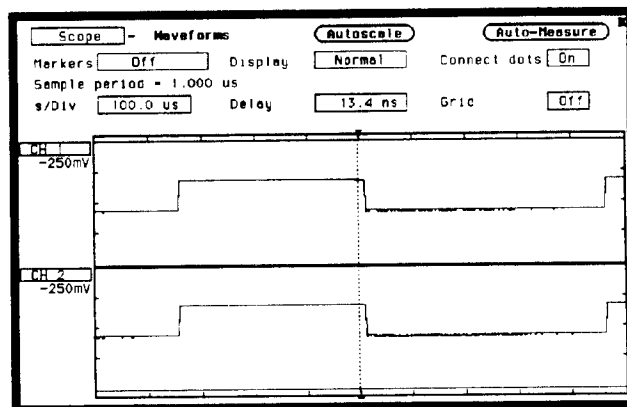

Figure 25-7. One Full Cycle Waveform

+ Width and -Width Measurements

+ Width (positive pulse width) and -Width (negative pulse width) measurements are made using the time (t) at the 50% level of the waveform edges. At least one positive-going edge followed by a negative-going edge of the waveform must be present to make a + Width measurement and at least one negative-going edge followed by a positive-going edge must be present to make a -Width measurement. If these conditions are not present, the + Width and/or -Width measurements in the auto-measure field will be blank.

If the first edge on the display is rising then:

$$+ \text{Width} = t_{\text{falling edge 1}} - t_{\text{rising edge 1}}$$

$$- \text{Width} = t_{\text{rising edge 2}} - t_{\text{falling edge 1}}$$

If the first edge on the display is falling then:

$$+ \text{Width} = t_{\text{falling edge 2}} - t_{\text{rising edge 1}}$$

$$- \text{Width} = t_{\text{rising edge 1}} - t_{\text{falling edge 1}}$$

3. Be sure the displayed waveform is at least one full cycle. If not, touch TRIG key, then select **s/Div**. Change s/Div field to $100 \mu\text{s}$ to display only one full cycle of the waveform. See figure 25-7.
- 4 Touch Display key, then select **Auto-Measure**. The Period and Freq measurements displayed in the Auto-measure listing pop-up is for the channel selected.

Preshoot and Overshoot Measurements

Preshoot and Overshoot measure the perturbation on a waveform above or below the top and base voltages (see "Top and Base Voltages" section earlier in this chapter). These measurements use all data displayed on screen, therefore it is very important that only the data of interest be displayed. If you want to measure preshoot and overshoot on one edge of a waveform, then only display that edge. If you want to measure the maximum preshoot and overshoot on a waveform, then display several cycles of the waveform.

Preshoot is a perturbation before a rising or a falling edge and is measured as a percentage of the top-base voltage. Overshoot is a perturbation after a rising or a falling edge and is measured as a percentage of the top-base voltage

If the measured edge is rising then:

$$\text{Preshoot} = \left[\frac{V_{\text{base}} - V_{\text{minimum}}}{V_{\text{top-base}}} \right] \times 100$$

$$\text{Overshoot} = \left[\frac{V_{\text{maximum}} - V_{\text{top}}}{V_{\text{top-base}}} \right] \times 100$$

If the measured edge is falling then:

$$\text{Preshoot} = \left[\frac{V_{\text{maximum}} - V_{\text{top}}}{V_{\text{top-base}}} \right] \times 100$$

$$\text{Overshoot} = \left[\frac{V_{\text{base}} - V_{\text{minimum}}}{V_{\text{top-base}}} \right] \times 100$$

Re-scale the waveform to display a rising edge, then make a Preshoot and Overshoot measurement on CH 1.

1. Select **s/Div** and change s/Div field to 5 ns to display a rising edge on the waveform. See figure 25-8.
2. Select **Auto-Measure**. Notice the Preshoot and Overshoot measurements displayed in the Automatic Measurement listing pop-up.

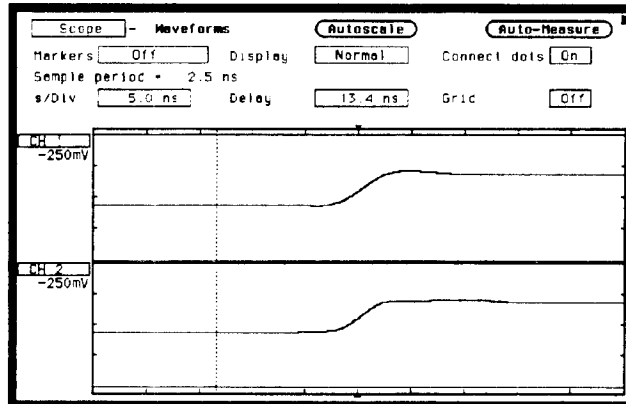

Figure 25-8. Rising Edge on Waveform

Marker Measurements

In addition to automatic parametric measurements, the oscilloscope also has two markers for making time and voltage measurements either manually (Time) or automatically (Search).

To demonstrate how to make marker measurements, connect the oscilloscope as shown in figure 25-3 and reset the oscilloscope as described below.

1. Turn the instrument on.
2. From the System Configuration menu, turn the oscilloscope on and all analyzers off.
3. Touch CHAN key, then from the default Channel Specification menu, make the following changes:

Input CH 1 Probe field to 1:1

Input CH 1 Impedance field to 50 Ohms

Input CH 2 Probe field to 1:1

Input CH 2 Impedance field to 50 Ohms

4. Select **Autoscale**, then select **Continue**.

5. Touch the TRIG key and set the Run mode to Repetitive.
6. Select the Waveforms menu and toggle Connect dots field to on. The displayed waveform should now look like figure 25-9.

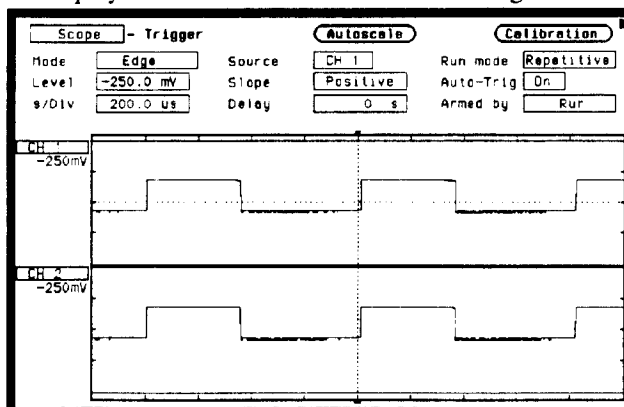

Figure 25-9. Marker Measurement Setup Display

Markers Field

In the Waveforms menu, the **Markers** field is located on the left side of the top row of fields, and can only be accessed from the Oscilloscope's Waveforms menu. When the Markers field is selected, a pop-up appears as shown in figure 25-10.

Marker field pop-up

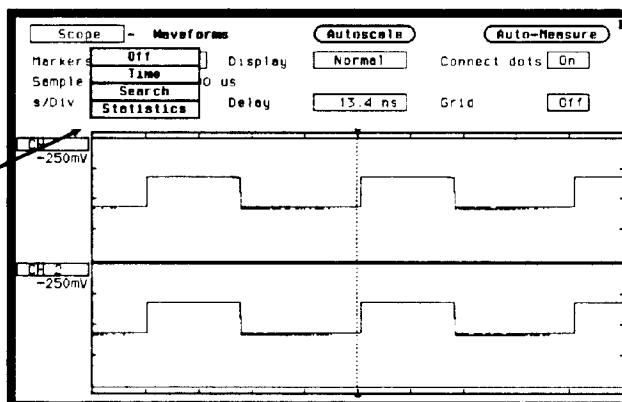

Figure 25-10. Markers Field Pop-up

The default selection for the Markers field is Off.

Sample Period Display

Any time the Markers field is Off, the sample period of the acquired waveform is displayed directly below the markers field. A sample period is the time period between acquired sample points and is the inverse of sample rate (digitizing rate). Sample period is a function of sweep speed and can only be changed by changing the s/Div field.

Time

When the Time field is selected from the Markers pop-up, the Sample period = __ disappears and a new middle row of fields appear in the Waveforms menu. See figure 25-11.

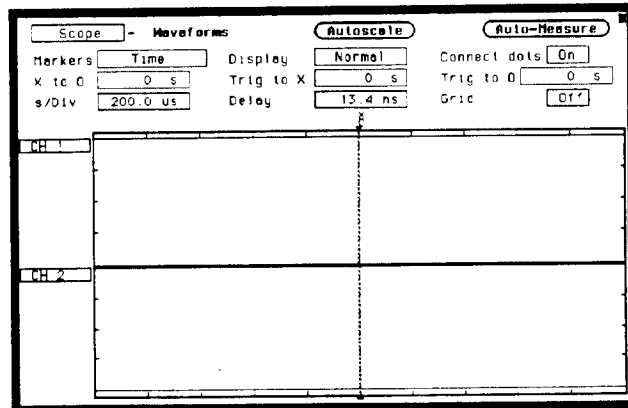

Figure 25-11. Time Markers Field Pop-up

X to O Field

The X to O field is located on the left side of the middle row of fields and displays the time (delta time) between the X marker and the O marker. When the X to O field is selected, turning the knob will move both the X and the O marker across the display without changing the value in the X to O field. However, the values in the Trig to X and Trig to O fields will change to reflect the movement of the X and O markers.

The value in the X to O field can be changed by changing the Trig to X or Trig to O values, or by changing the X to O value from the pop-up. The knob entry pop-up will appear when you select the X to O field.

When the time value of X to O is changed using the knob, half the difference of the new value and old value is subtracted from the X marker and half is added to the O marker.

Trig to X Field

The Trig to X field is located in the middle of the middle row of fields. The X marker is shown on the waveform display as a dotted line with an X above it. The time displayed in the Trig to X field is measured from the trigger point to the X marker. The trigger point is marked with a dotted line on the waveform display and is always time 0.

When the Trig to X field is selected, the time value can be changed by turning the knob or by entering a time value from the Numeric Entry pop-up. The Numeric Entry pop-up will appear when any key is touched on the keypad.

Resolution for the Trig to X time values is 2% of the sweep speed setting. The default value for the Trig to X field is 0 s.

Trig to O Field

The Trig to O field is located on the right side of the middle row of fields. The O marker is shown on the waveform display as a dotted line with an O above it. The time displayed in the Trig to O field is measured from the trigger point to the O marker.

When the Trig to O field is selected, the time value can be changed by turning the knob or by entering a time value from the Numeric Entry pop-up. The pop-up will appear when any key is touched on the keypad.

Resolution for Trig to O time values is 2% of the sweep speed setting. The default value for the Trig to O field is 0 s.

Search When **Search** is selected from the **Markers** field, a new middle row of fields and the **Specify Search Markers** field will appear. See figure 25-12.

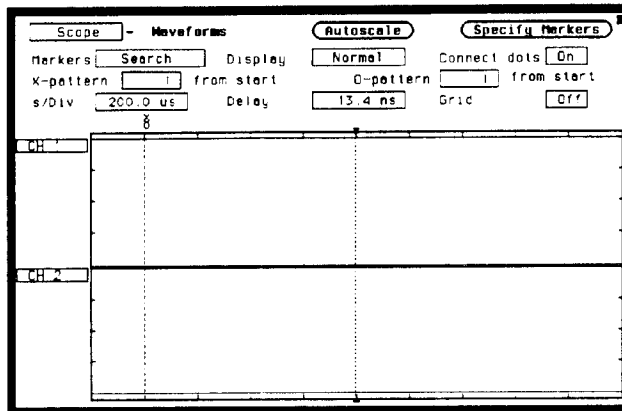

Figure 25-12. Search fields

Specify Search Markers The **Specify Search Markers** field is located in the upper right corner of the **Waveforms** menu. When selected, a **Search Markers** pop-up will appear. After **Search Markers** criteria is set, the X and O markers will be positioned on the waveform, as specified, with voltage values displayed below the waveform label. See figure 25-13.

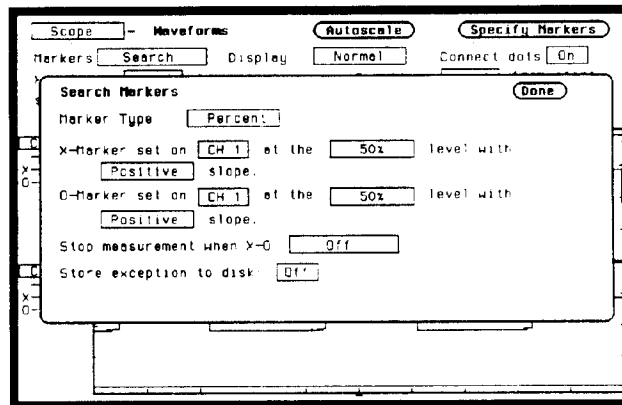

Figure 25-13. Search Markers Pop-up

Type markers

When the **Type markers** field is selected, it will toggle between Percent and Absolute.

The **Percent** type setting is for levels that are a percentage of the top-to-base voltage value of a waveform. The top-to-base voltage value of a square wave is typically not the same as the peak-to-peak value. The oscilloscope determines the top and base voltages by finding the flattest portions of the top and bottom of the waveform. See figure 25-14. The top and base values do not typically include preshoot or overshoot of the waveform. The peak-to-peak voltage is the difference between the minimum and maximum voltage found on the waveform.

The **Absolute** type allows you to set an exact voltage level to the X or O marker.

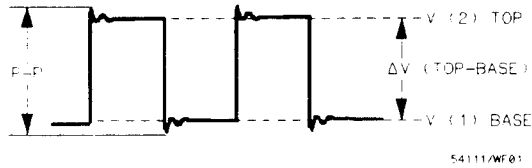

Figure 25-14. Top And Base Levels

X-Marker set on

O-Marker set on

The X-O Marker set on__ field assigns an input waveform (CH1 or CH2) to the X or O marker. When you select this field, the field will toggle between the waveform sources.

The default selection for the **Marker set on__** field is CH1.

at the ___ level

When the type marker is set to Percent, the **at the ___ level** field sets the X or O marker to a percentage level (from 10% to 90%) of the top-base voltage. When the type marker is set to Absolute, you can set the marker to an exact voltage level.

The Percentage or Absolute voltage can be changed by turning the knob or by entering a value from the keypad. Percent values from 10% to 90% in increments of 1% can be entered. Absolute voltage values can be entered in increments of 6 mV. The Percent default value for the **at the ___ level** field is 50%. The Absolute default value for the **at the ___ level** field is 0 V.

with ___ slope.

The **with ___ slope** field sets the X or O marker on either the positive or negative edge of the selected occurrence of a waveform. When the slope field is selected, the slope will toggle between Positive and Negative. The default selection for the Slope field is Positive.

Stop measurement when X-O ___

This field lets you set up a stop condition for the time interval between the X marker and O marker. When this field is selected, a pop-up will appear as shown in figure 25-15.

The default selection for the **Stop measurement when X-O** field is Off.

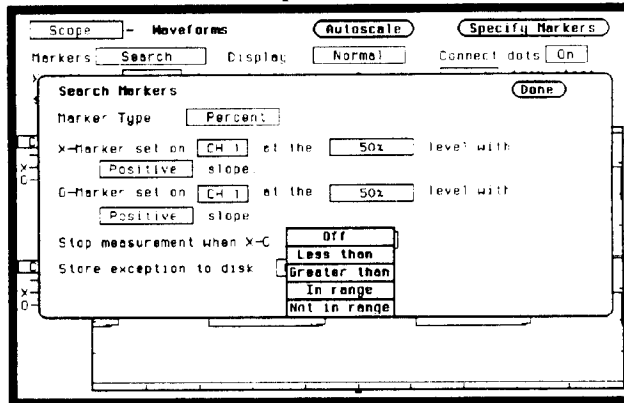

Figure 25-15. Stop Measurement Pop-up

Less than

When the **Less than** field is selected from the pop-up, a time value field appears to the right of the **Less than** field. See figure 25-16.

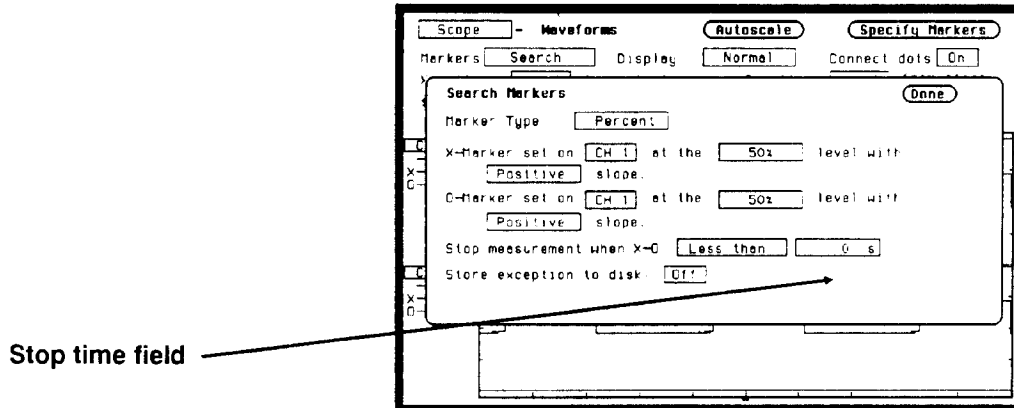

Figure 25-16. Stop Measurement Time Field

When the time value field is selected, the time value can be entered by the keypad. See figure 25-17.

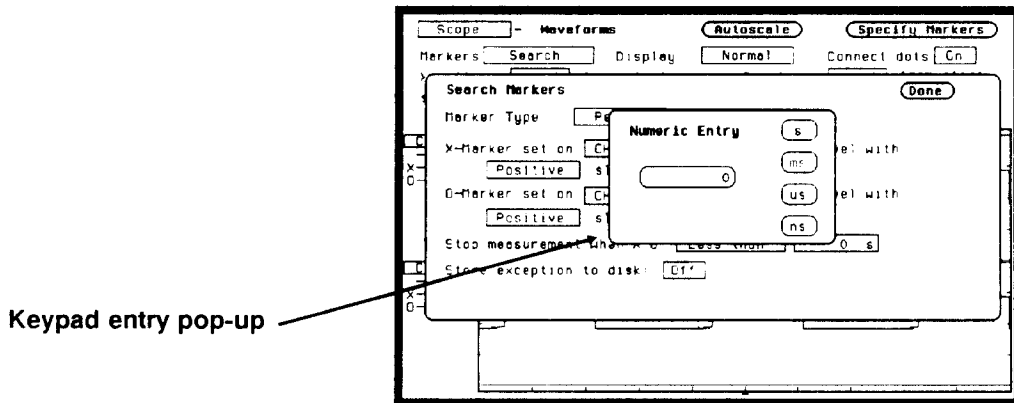

Figure 25-17. Stop Measurement Time Numeric Entry

The keypad will appear when you touch any key. The knob is used to set the scale. When using the keypad, resolution is 10 ns at times up to 99.99 ns and can be set to 5-digit resolution for other times up to 100 Megaseconds. Positive times would be used when the X marker is displayed before the O marker, and negative times would be used when the O marker is displayed before the X marker.

When **Less Than** is selected, the oscilloscope will run until the X-O time interval is less than the value entered for the **Less Than** time field. When the condition is met, the oscilloscope will stop acquisitions and display the message "Stop condition satisfied."

Greater than

When the **Greater than** field is selected from the pop-up, a time value field appears to the right of the **Greater Than** field. When the time value field is selected, the time and scale can be entered the same as for the Less Than field.

When **Greater Than** is selected, the oscilloscope will run until the X-O time interval is greater than the value entered for the **Greater Than** time field. When the condition is met, the oscilloscope will stop acquisitions and display Stop condition satisfied.

In range ___ to ___

When the **In range___to___** field is selected from the pop-up, two time value fields appear next to the **In range** field. See figure 25-18. The time range for the stop condition is entered using the keypad. When either time value field is selected, the time value can be entered the same as for the **Less Than** field. Default values for **In range___to___** is 10 ns.

When **In range___to___** is selected, the oscilloscope will run until the X-O time interval is in the range of the time values entered for the **In range___to___** time fields. When the condition is met, the oscilloscope will stop acquisitions and display Stop condition satisfied.

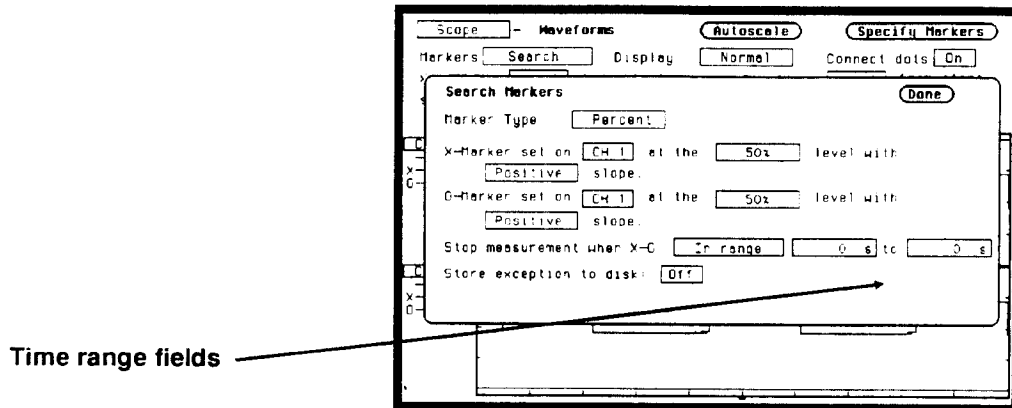

Figure 25-18. Range Fields

Not in range ___ to ___

When the **Not in range___to___** field is selected from the pop-up, two time value fields appear next to the **Not In Range** field. The time range for the stop condition is entered in these time fields. When either time value field is selected, the time can be entered the same as for the **Less Than** field.

When **Not In range___to___** is selected, the oscilloscope will run until the X-O time interval is not in the range of the time values entered for the **Not in range___to___** time fields. When the condition is met, the oscilloscope will stop acquisitions and display Stop condition satisfied.

Default values for these fields are 10 ns.

Store exception to disk

When the **Store exception to disk:** field is on, any time the Stop measurement when X-O criterion is met, the measurement is stored to a file on disk. You can designate a **File name** and add a **File description** by selecting those fields and using the Alpha Entry pop-up. After the measurement is stored, the acquisition cycle continues. If the disk is write protected, a notice is displayed and the acquisition cycle is stopped. If the **Stop measurement when X-O** field is off, the Store exception to disk: function is disabled.

X-pattern ___ from start

O-pattern ___ from start

The X and O **pattern___from start** field sets the X or O markers on a specific occurrence of an edge on the waveform. The edge may be the 1st displayed up to the 1024th displayed. The count of edge occurrences is made starting with the first edge displayed on screen, either partial or full.



Auto-marker measurements are made with data that is displayed on screen. Make sure the data of interest is fully displayed on screen. For example, if only part of a positive edge is displayed, the 0% point and 100%-point of the edge is calculated from what is actually displayed on screen. This could cause measurement errors.

When the X or O **pattern___from start** field is selected, the occurrence can be changed by turning the knob or by entering a new value from the pop-up keypad. The keypad will appear when you make the first entry on the keypad. Any number from 1 to 1024 in increments of 1 can be entered.

The default value for the **pattern___from start Occur** field is 1.

Statistics The last field in the Markers pop-up shown in figure 25-10 is **Statistics**. When Statistics is selected from the Markers field, a new middle row of fields appear. See figure 25-19.

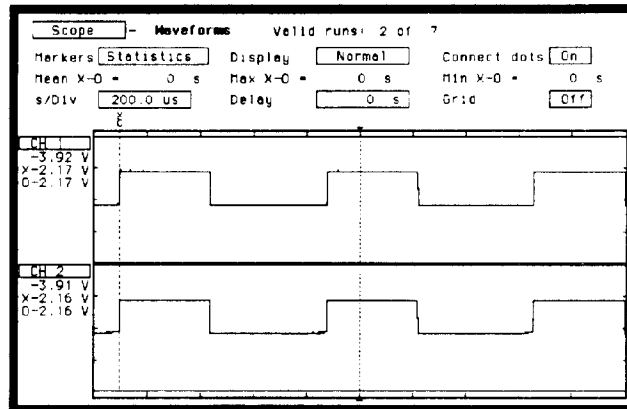

Figure 25-19. Statistics Fields

The Statistics field allows you to make minimum, maximum, and mean time interval measurements from marker X to marker O.

Minimum, maximum, and mean (average) X-O marker time interval data is accumulated and displayed until one of the following happens:

1. Autoscale is executed.
2. Auto-marker parameters are changed.
3. Statistics is set to Off.
4. Repetitive Run mode is stopped.

The default for the Min, Max, and Mean fields is 0 s.

Search Marker Measurement Example

The following example will show how to make an automatic marker measurement using the Search markers. We will set the markers to make an X-O marker measurement on the CH 1 and CH 2 input waveforms. We want to measure the time between the falling edge of the 2nd displayed pulse on CH 1 to the rising edge of the 5th displayed pulse on CH 2. We'll perform the measurement from the 10% point on CH1 to the 90% point on CH 2.

Connecting the Equipment

Connect the equipment as shown in figure 25-20.

Note 

An extra long BNC cable is used on channel 2 so the signal is delayed.

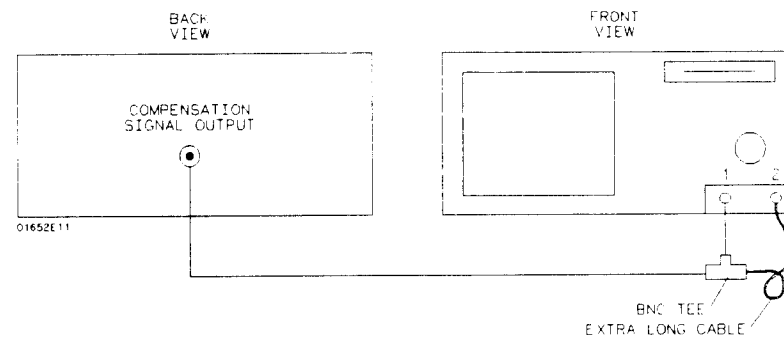

Figure 25-20. Equipment Setup For Search Marker Example

Making the Measurement

1. In the Waveforms menu, select **Markers** field. When the pop-up appears, select the **Search** field. With Markers set to Search, two new fields will appear: **X-pattern** from start, and **O-pattern** from start. Set the X-pattern to 2, and the O-pattern to 5. Set the s/Div to 500 μ s. See figure 25-21.

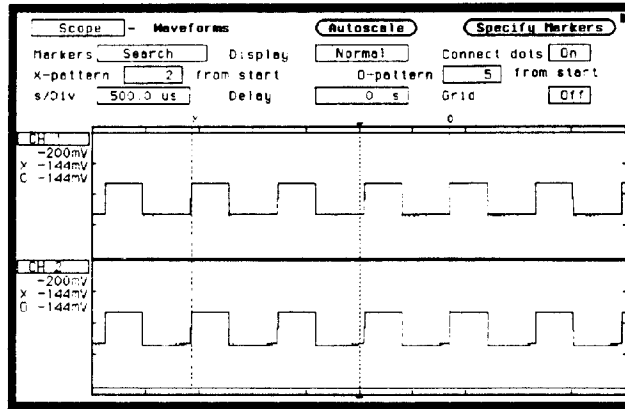

Figure 25-21. Search Markers Menu

2. Select **Specify Search Markers**. Set the Search Markers pop-up as shown in figure 25-22.

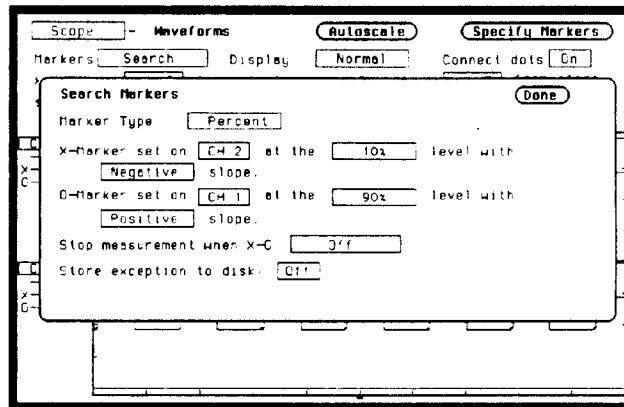

Figure 25-22. Specify Search Markers Pop-up

3. Select the **Done** field to return to the waveform display.

The X marker is on the falling edge of the 2nd displayed pulse and the O marker is on the rising edge of the 5th displayed pulse. See figure 25-23.

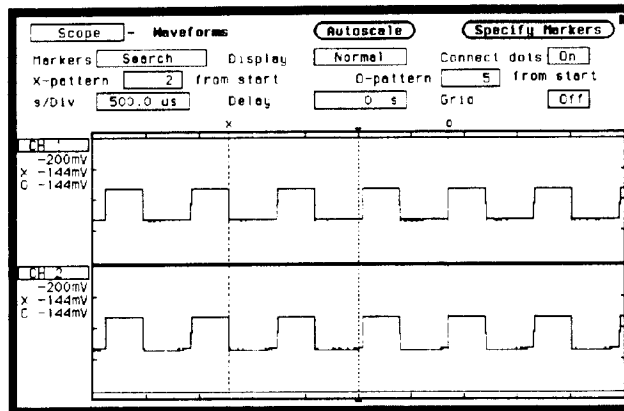

Figure 25-23. Search Marker Measurement Waveform

4. Select the **Markers** field and switch from Search to Statistics. Notice the statistical minimum, maximum, and mean time interval measurements between the X and the O markers are also displayed. The voltage measurements of where the markers intersect the waveforms are displayed under the CH 1 and CH 2 channel labels.
5. Select the **Delay** field, and turn the knob. Notice that as the waveform is moved across the display, the X and O markers also move to the edges specified in the Search Markers pop-up menu.
6. Set the Delay time back to 0 s.

Now let's use the **Stop measurement when X-O** feature for an X-O measurement.

1. Select the **s/Div** field and turn the knob to change the sweep speed to 5 ns.
2. Select the **Markers** field and select Search from the pop-up.
3. Set X-pattern and O-pattern to 1 from start.
4. Select **Specify Search Markers** and set Pop-up as shown in figure 25-24.

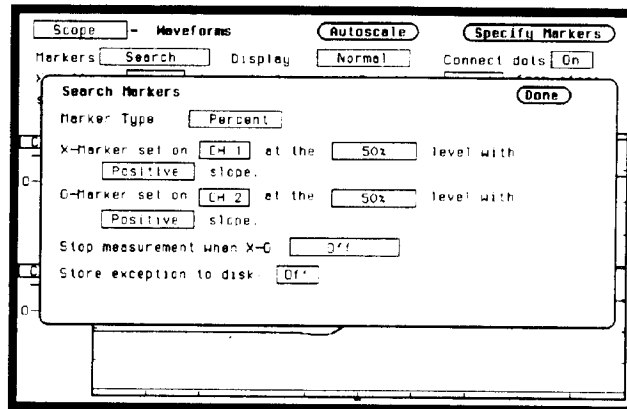

Figure 25-24. Specify Search Markers Pop-up

5. Select **Stop measurement when X-O** and select **Less Than** from the pop-up.
6. Select the time field next to the **Less Than** field. Set the time field to 10 ns.

7. The Specify Search Markers pop-up now looks like figure 25-25.

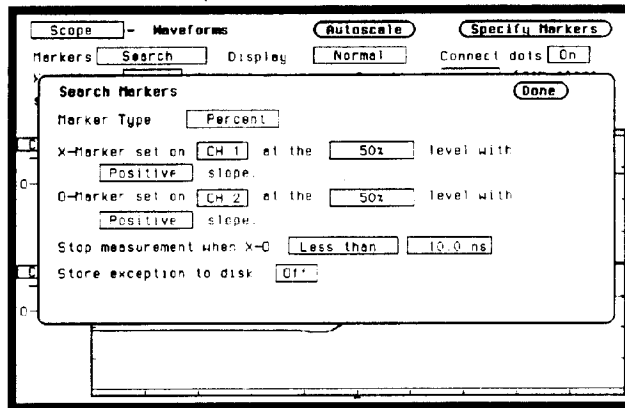

Figure 25-25. Stop Measurement Less than Setup

8. Select the Done field to return to the waveform display. The display now looks like figure 25-26.

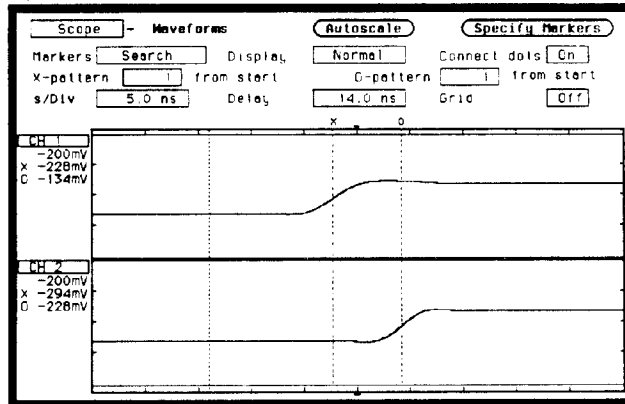

Figure 25-26. Waveform Display

The time interval from X-O in this example is 6.5 ns. Your results may be different because of the different length of BNC cable used to delay channel 2. The oscilloscope was instructed to run until the time interval was less than 5 ns. When the stop condition was satisfied, the oscilloscope stops acquisition and displays the advisory "Stop run criteria met - run stopped."

Display Field

The **Display** field is located in the middle of the top row of fields. When this field is selected, a pop-up appears as shown in figure 25-27. The selections in this pop-up determine how waveform information is displayed.

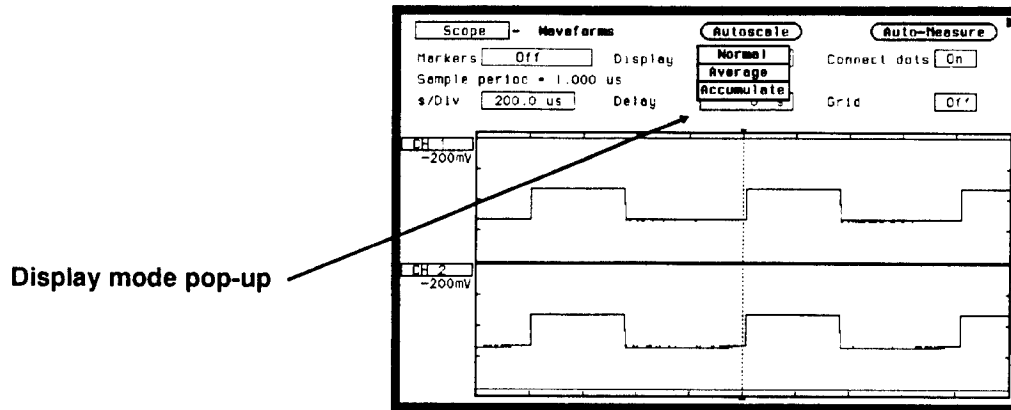

Figure 25-27. Display Field Pop-up

The default selection for the Mode field is Normal.

Normal Mode

In Normal mode, the oscilloscope acquires waveform data and then displays the waveform. When the oscilloscope makes a new acquisition, the previously acquired waveform is erased from the display and replaced by the newly acquired waveform.

Average Mode In Average mode, the oscilloscope averages the data points on the waveforms with previously acquired data. Averaging helps eliminate random noise from your displayed waveforms. When the Average field is selected from the Display mode pop-up, an integer field appears to the right of the AVG# field. When this Average integer field is selected, an integer selection list pop-up appears, listing all possible average selections.

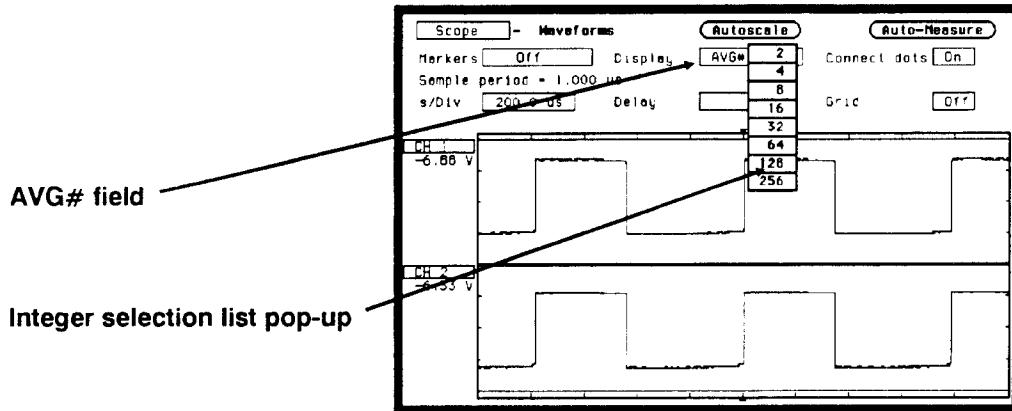

Figure 25-28. Average Integer Entry Pop-up

The number of averages can be changed by turning the knob to position the cursor over the integer you want and pressing the SELECT key.

As an example, assume the Average integer field is set to 16. If the Run mode is set to Repetitive, the oscilloscope will immediately start acquiring waveform data and average them together. When the initial 16 waveforms have been acquired, the oscilloscope will momentarily display the advisory "Number of averages have been met". Once the initial 16 waveforms have been acquired, the oscilloscope will only average the last 16 waveforms acquired; all other data will be discarded.

If the Run mode is set to Single, an acquisition is not made until the Run field has been selected. If Average # is set to 16, as in the previous example, the message "Number of averages have been met" would not be displayed until Run has been selected 16 times.

To exit the Average mode, select the **AVG#** field next to the Average Integer field. The default value for the Average # field is 8.

Accumulate Mode

In Accumulate mode, the oscilloscope accumulates all waveform acquisitions on screen without erasing the previously acquired waveforms. This is similar to infinite persistence on an analog storage oscilloscope. These acquisitions will stay on the display until Mode is changed, or until the waveform is adjusted by a control that causes the display to change, such as s/Div or V/Div.

Connect Dots Field

The **Connect dots** field is located on the right side of the top row of fields. When Connect dots field is selected, it will toggle between on and off.

When Connect dots is On, each displayed dot will be connected to the adjacent dot by a straight line. A waveform with Connect Dots set to On, will be well defined and easier to see.

The default setting for the Connect dots field is Off.

Grid

When the **Grid** field is selected, it will toggle between on and off. When the grid is turned on, the major divisions for both time and voltage will be marked with dotted lines.

Mixed Mode Displays

Introduction

This chapter explains mixed mode displays for:

- timing/state
- state/state
- timing/scope
- state/timing/scope

The Mixed Mode waveform display will display all of the above mentioned combinations. The main menu and field definitions for each individual type of display is explained in their respective chapters. Only the unique functions and features of the mixed mode displays are given here.

Mixed Mode field

The Mixed Mode field is located in the same pop-up that is used to access the System Configuration menu, analyzers and the scope. See figure 26-1. The Mixed Mode field will only be available from the Waveform and Listing menus.

Before mixed mode displays can be displayed, the appropriate analyzers and/or scope must be turned on and the appropriate channels or pod bits assigned.

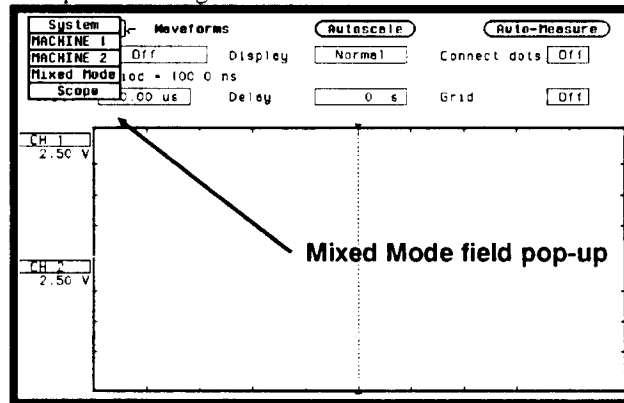

Figure 26-1. Mixed Mode Field

Timing/State Mixed Mode Display

When both timing and state analyzers are on you can display both the State Listing and the Timing Waveforms simultaneously as shown in figure 26-2.

The data in both parts of the display can be time-correlated as long as Count (State Trace menu) is set to Time.

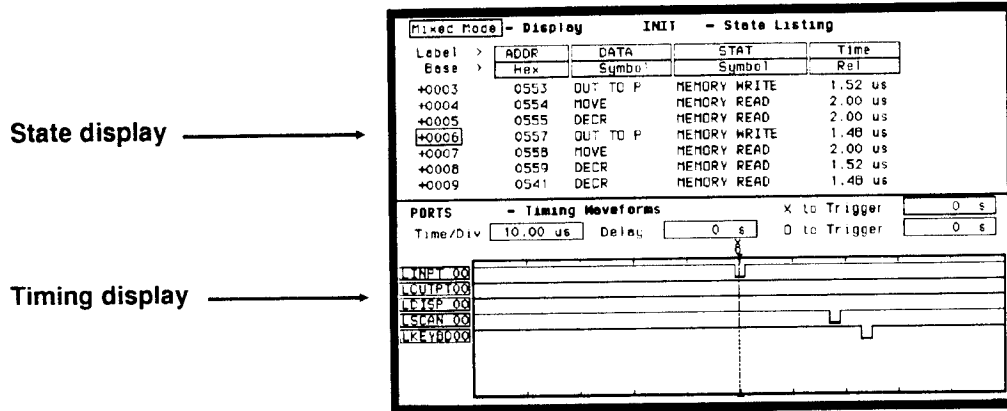

Figure 26-2. Timing/State Mixed Mode Display

The markers for the State Listing and the Timing Waveform in time-correlated Mixed Mode are different from the markers in the individual displays. You will need to place the markers on your points of interest in the time-correlated Mixed Mode even though you have placed them in the individual displays.

State/State Mixed Mode Display

When two state analyzers are on, the logic analyzer will display both state listings as shown below. Data from state machine 1 is the data with the normal memory location columns filled and with normal black on white video. State machine 2 data is interlaced and displayed in inverse video (white on black). Its memory locations are offset to the right in a column.

Label	Base	ADDR	DATA	DATA	STATUS	Time	STATE
		Hex	Hex	ASCII	Symbol	Rel	Symbol
+0004							
+0018		0395	ED			467.4 us	OPCODE FETCH
+0019		0397	78			680 ns	OPCODE FETCH
+0020		6006	E2			920 ns	I/O READ
+0021		03C5	ED			7.24 us	OPCODE FETCH
+0022		03C6	79			680 ns	OPCODE FETCH
+0023		6008	62			920 ns	I/O WRITE
+0005							
+0024		0396	ED			469.2 us	OPCODE FETCH
+0025		0397	78			640 ns	OPCODE FETCH
+0026		6006	80			920 ns	I/O READ
+0027		03C5	ED			7.28 us	OPCODE FETCH
+0028		03C6	79			640 ns	OPCODE FETCH
+0029		6008	0D			920 ns	I/O WRITE
+0006							
+0030		0396	ED			464.4 us	OPCODE FETCH

Figure 26-3. State/State Mixed Mode Display

To time-correlate data from two state machines, you must set the Count (State Trace menu) for both machines to Time.

The markers for a State/State time-correlated Mixed Mode will be the same as the markers placed in each of the individual State Listings.

Timing/Scope Mixed Mode Display

When the timing analyzer and the oscilloscope are both on, you can display both the timing waveform and oscilloscope waveform simultaneously as shown below.

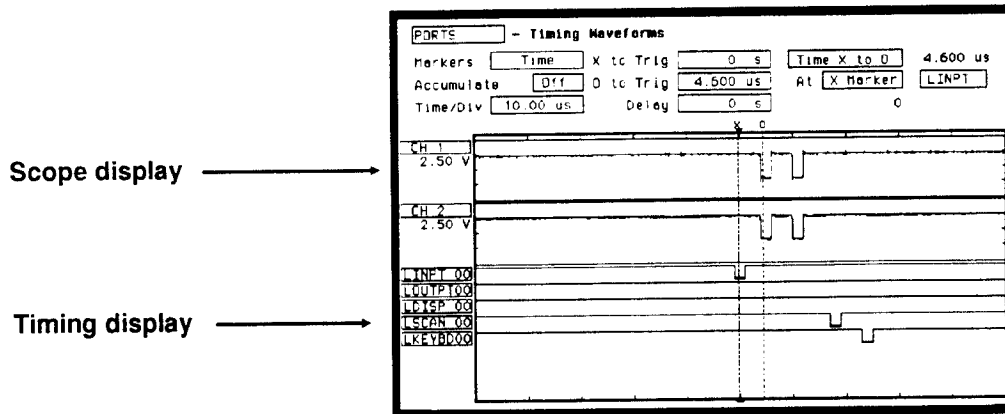

Figure 26-4. Timing/Scope Mixed Mode Display

Arming the Oscilloscope

Both the state and timing analyzers can arm the oscilloscope. However, to display scope and timing waveforms together in the same display, one (either scope or timing) must arm the other. In addition, after proper arming, the scope and timing waveforms can be time-correlated by setting the scope to trigger Immediately.

From the Trigger Specification menu, select the **Armed by** field. A pop-up will appear with all the arming choices. Select the analyzer machine which you have assign as the timing analyzer in the System Configuration menu. For more information see the chapter "Trigger Menu".

Displaying Timing Waveforms

After the oscilloscope has been armed by the timing analyzer, the pods can be assigned and accompanying waveforms displayed in the oscilloscope waveform display. To setup mixed mode display in the oscilloscope waveforms display, follow the steps below:

1. From the waveforms display menu, select a channel label. Remember that the inserted waveform will be placed directly below the label you choose.
2. From the waveform selection pop-up shown in figure 26-5, select **Insert waveform** field.

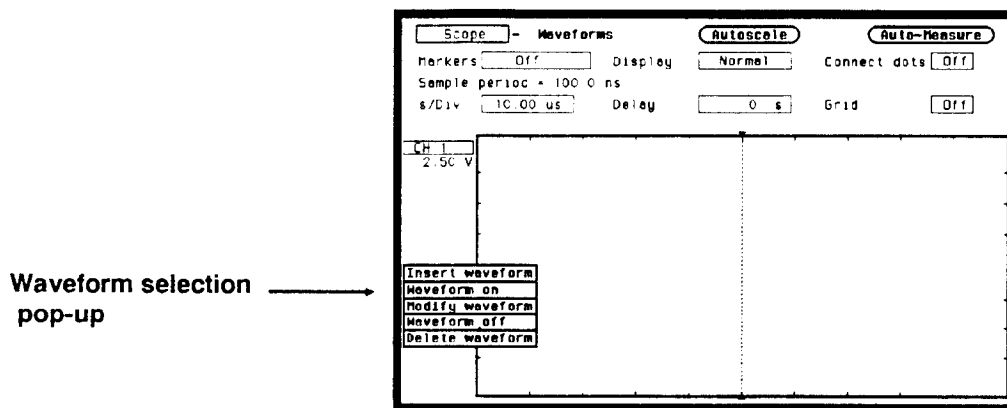

Figure 26-5. Waveform Label Pop-up

3. Since the timing analyzer machine is arming the oscilloscope, another pop-up will appear as shown in figure 26-6 that gives you a choice of Scope or Timing. Select Timing.

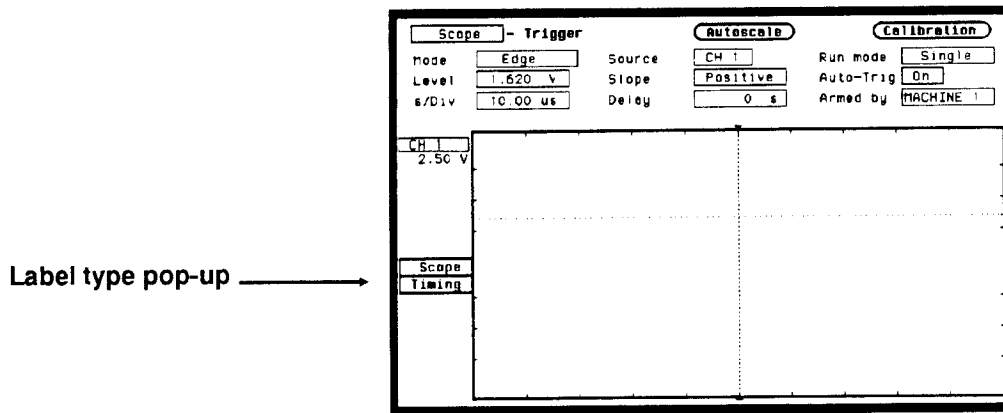

Figure 26-6. Label Type Pop-up

4. A field labeled POD 1 will appear as shown in figure 26-7.

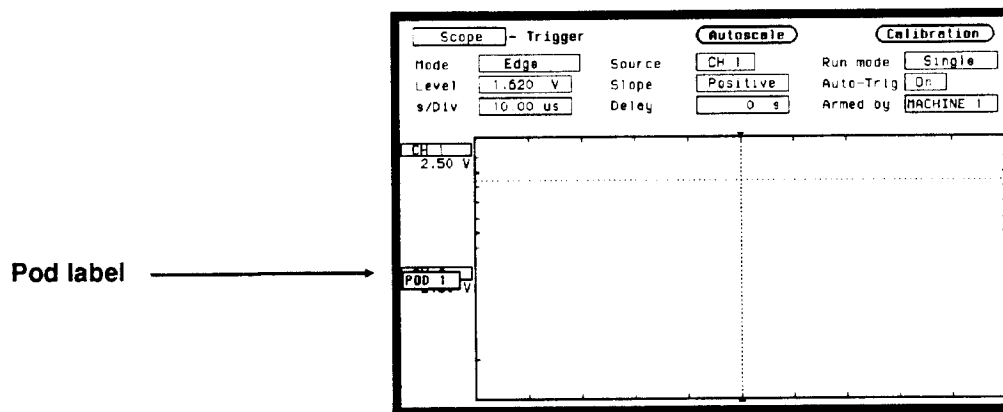

Figure 26-7. Pod Label Field

5. Touch the Select key again and POD 1 will be inserted.
6. Each pod that is inserted, will have the bit number incremented by one, starting from "00". To modify the bit number, select the **Bit select** field which is just to the right of the Pod number. See the Bit selection field in figure 26-8.

7. When the Bit select pop-up appears, enter the bit number you want by rotating the knob or by using the keypad. The keypad will appear when the first key is touched. See figure 26-8.

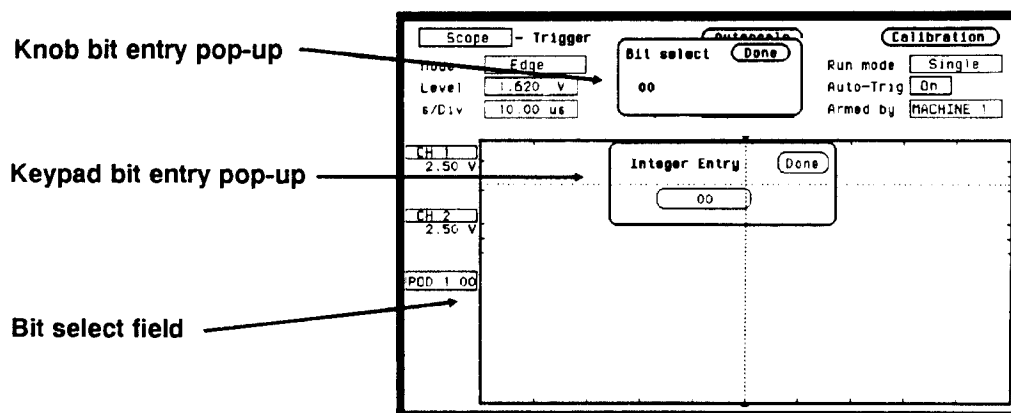

Figure 26-8. Knob And Keypad Entry Pop-ups

The markers for the oscilloscope in time-correlated Mixed Mode are different from the markers in the individual waveforms display. You will need to place the markers on your points of interest in the time-correlated Mixed Mode even though you have placed them in the individual displays.

State/Timing And Scope Mixed Mode Display

When the state analyzer, timing analyzer and the oscilloscope are all on, you can display both analyzer waveforms and the oscilloscope waveforms simultaneously as shown below.

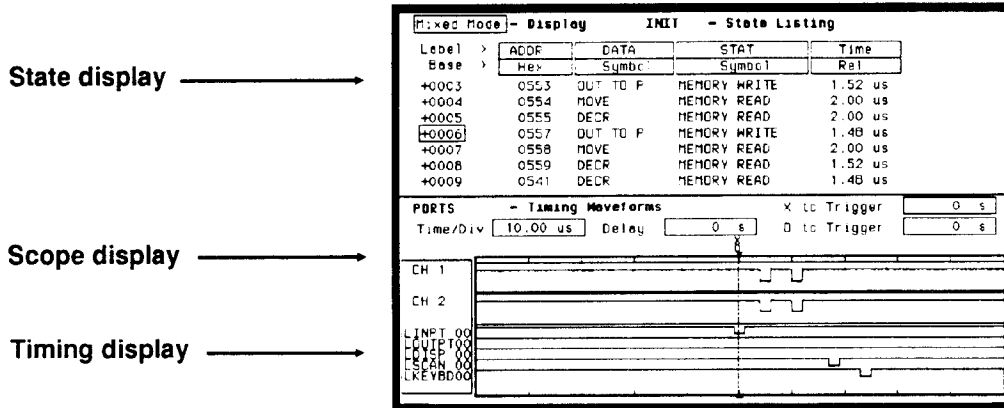

Figure 26-9. State/Timing/Scope Mixed Mode Display

The arming requirements for the oscilloscope are the same as in timing/scope mixed mode displays.

The procedure for inserting waveforms in the timing waveforms display is the same as in timing/scope mixed mode displays.

The markers for the state analyzer, timing analyzer and oscilloscope in time-correlated Mixed Mode are different from the markers in the individual waveforms and listing displays. You will need to place the markers on your points of interest in the time-correlated Mixed Mode even though you have placed them in the individual displays

Time-Correlated Displays

The HP1652B/1653B Logic Analyzers can time-correlate data between the timing analyzer and the state analyzer (see Timing/State Mixed Mode Display) between two state analyzers (see State/State Mixed Mode Display) and between the state analyzer, the timing analyzer and the scope (see State/Timing And Scope Mixed Mode Display).

The logic analyzer uses a counter to keep track of the time between the triggering of one analyzer and the triggering of the second. It uses this count in the mixed mode displays to reconstruct time-correlated data.

To summarize time-correlation between the different displays, remember the following.

To time-correlate the state analyzer display to the timing analyzer display, **arm the timing analyzer** with the state analyzer, then set the state analyzer count mode to **Time**.

Then, to add the scope display, **arm the scope** with the timing analyzer and set the scope to trigger **Immediate**.

Timing/State/Oscilloscope Measurement Example

Introduction

In this chapter you will learn how to use the timing analyzer, state analyzer, and oscilloscope interactively by setting up the logic analyzer menus to simulate the process of making a measurement. We will give you the measurement results, as actually measured by the logic analyzer, since you will not have the exact same circuit available.

This measurement example uses an HP 1652B (five pods). The steps for setting up the analyzer menus are ordered in a manner you would naturally take if you were actually troubleshooting this problem.

Since you've already had some practice at setting up both the timing and state analyzers in previous examples, you should be able to setup the analyzer menus by looking at the pictures. If you can set up each menu by just looking at the menu pictures, go ahead and do so. If you need a reminder of what steps to perform, follow the numbered steps.

Problem Solving with the Timing/State/Scope Analyzer

In this example assume you have a microprocessor-controlled circuit that sequentially accesses five ports and reports back any that do not respond correctly. After power-up, the system indicates that two of the ports are not responding. The block diagram shown below helps to illustrate the system under test and its problem.

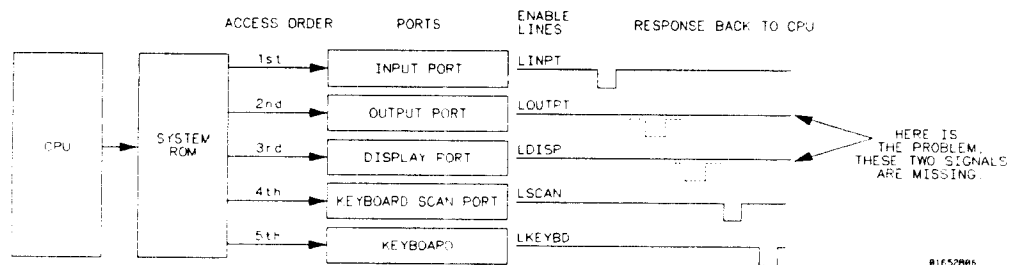

Figure 27-1. System Under Test With Problem

What Am I Going to Measure?

The circuit under test is actually hardware being controlled by firmware. The code stored in the system ROM (Read Only Memory) could be faulty, or there could be a hardware problem, such as a bad IC or shorts/opens on the PC board.

Your measurement should verify the following:

- Whether the code in system ROM is correct.
- Whether the ICs are functioning properly.
- Whether any board shorts/opens exist.

Before you begin your troubleshooting process, you should recognize the strengths of your tools.

1. Your state analyzer can look at the actual code in ROM that controls the circuit operation. In addition, you can use the state analyzer to control (through arming and triggering) the starting point of all other measurements.
2. Your timing analyzer can verify the hardware has correctly translated the code in ROM into the five sequential enable signals with the required timing relationships.
3. Your oscilloscope can then look at any signal lines for closer examination of such things as noise, spikes, slow pulse transitions, signal amplitude, and any open or shorted conditions.

The measurement sequence should follow the same order. First **verify the system code (state analyzer)**, then look at the **relationships between multiple signals (timing analyzer)**, then take a closer look at any unusual looking signal lines for the **final analysis (oscilloscope)**.

How Do I Configure the Logic Analyzer?

The first part of your measurement is to verify that all 5 ports are initialized by the software in the power-up initialization routine. To do this, you will configure the logic analyzer as a state analyzer.

Configure the System Configuration menu as shown below, so Analyzer 1 is a state analyzer. For this example, the label INIT was chosen for you to describe the INITIALization routine.

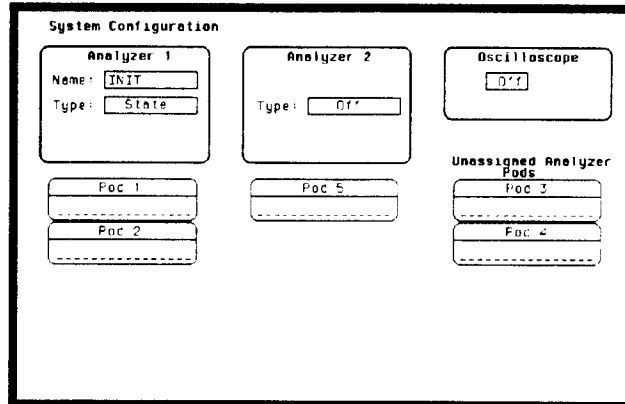

Figure 27-2. Set System Configuration Menu

1. Select **Type** field in Analyzer 1.
2. Select the **State** field.
3. Select **Pod 2** field and assign it to Analyzer 1.

Configuring the State Analyzer

Now that you have configured the system, you are ready to configure the state analyzer. Set the State Format Specification menu as shown in figure 27-3. For this example, the labels ADDR, DATA, and STAT are chosen for you to describe address lines, data lines and CPU status.

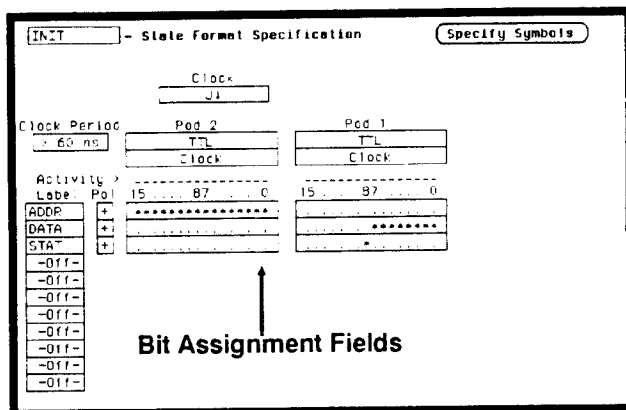

Figure 27-3. Configure the State Format Menu

1. Press FORMAT key on front panel.
2. Select Pod 2 (ADDR) bit assignment field and turn bits 0 through 15 on. These are the address lines.
3. Select Pod 1 (DATA) bit assignment field and turn bits 0 through 7 on. These are the data lines.
4. Select Pod 1 (STAT) bit assignment field and turn bit 8 on. This is the CPU Read/Write line.

You want the state analyzer to trigger and start storing states when it encounters the beginning of the initialization routine. This happens at the specific state (0550). To accomplish this, configure the State Trace Specification menu as shown below.

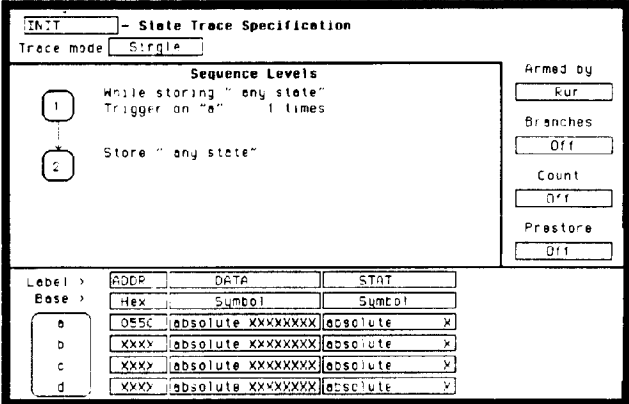

Figure 27-4. Configure the State Trace Menu

1. Press TRACE key on front panel.
2. Select the pattern field and insert the address you want the analyzer to trigger on (0550).

Connecting the Probes

At this point, if you had a target system, you would connect the logic analyzer to your system. Since we have assigned labels ADDR, DATA and STAT, you would connect the probes to your system accordingly.

- Pod 1 probes 0 through 7 to the data bus lines D0 through D7
- Pod 1 probe 9 to the CPU Read/Write control line
- Pod 2 probes 0 through 15 to the address bus lines A0 through A15

Acquiring the Data

You have configured the State Trace Specification menu to start acquiring data when the microprocessor sends address 0550 on the bus. When you press the RUN key, the state analyzer waits until it sees address 0550, then triggers itself, and completes the state data acquisition. The display will then switch automatically to the State Listing menu.



We have assigned symbols for DATA and STAT in the State Listing display for you to better illustrate where the routine executes a memory write to the output ports.

example: 0550 OUT TO P MEMORY WRITE

Finding the Problem

You look at the state listing menu to see what the data is in states + 0000 through + 0013. These are the first stored states after trigger. You know your routine has five "OUT TO PORT" memory writes.

The microprocessor, does address the correct memory locations. Now you compare the data from the software engineer as listed below, with what is listed in the State Listing menu in figure 27-5.

```

0550   OUT TO PORT   MEMORY WRITE
0551   MOVE         MEMORY READ
0552   DECR        MEMORY READ
0553   OUT TO PORT   MEMORY WRITE
0554   MOVE         MEMORY READ
0555   DECR        MEMORY READ
0557   OUT TO PORT   MEMORY WRITE
0558   MOVE         MEMORY READ
0559   DECR        MEMORY READ
0541   DECR        MEMORY READ
0182   OUT TO PORT   MEMORY WRITE
0542   MOVE         MEMORY READ
0543   DECR        MEMORY READ
0544   OUT TO PORT   MEMORY WRITE
  
```

The screenshot shows a window titled "INIT - State Listing" with a "Markers" field set to "OFF". Below is a table with the following columns: Label, ADDR, DATA, C-A, and Time. The data rows are as follows:

Label	ADDR	DATA	C-A	Time
Base	Hex	Symbol	Symbol	Rel
+0000	0550	OUT TO P	MEMORY WRITE	1.48 us
+0001	0551	MOVE	MEMORY READ	3.00 us
+0002	0552	DECR	MEMORY READ	2.00 us
+0003	0553	OUT TO P	MEMORY WRITE	1.52 us
+0004	0554	MOVE	MEMORY READ	2.00 us
+0005	0555	DECR	MEMORY READ	2.00 us
+0006	0557	OUT TO P	MEMORY WRITE	1.48 us
+0007	0558	MOVE	MEMORY READ	2.00 us
+0008	0559	DECR	MEMORY READ	1.52 us
+0009	0541	DECR	MEMORY READ	1.48 us
+0010	0182	OUT TO P	MEMORY WRITE	2.00 us
+0011	0542	MOVE	MEMORY READ	1.52 us
+0012	0543	DECR	MEMORY READ	2.00 us
+0013	0544	OUT TO P	MEMORY WRITE	1.48 us
+0014	0545	MOVE	MEMORY READ	2.00 us
+0015	089C	MOVE	MEMORY READ	3.00 us

Figure 27-5. State Listing Menu

Since the data stored in memory is correct, it's time to look at the hardware to see if it's causing problems during the initialization routine. You decide to look at the activity on the enable lines during this routine.

In order to see time domain measurements on hardware signals, you need the timing analyzer.

What Additional Measurements Must I Make?

Since the problem exists during the routine that starts at address 0550, you decide to look at the timing waveforms on the enable lines when the routine is running.

Your measurement, then, requires verification of:

- actual response of enable lines from the five ports.
- correct timing of the responding enable lines.

How Do I Re-configure the Logic Analyzer?

In order to make this measurement, you must re-configure the logic analyzer so Analyzer 2 is a timing analyzer. You leave Analyzer 1 as a state analyzer since you will use the state analyzer to trigger the timing analyzer.

Configure the logic analyzer so Analyzer 2 is a timing analyzer as shown below. For this example, the label PORTS was selected for you to describe the output ports.

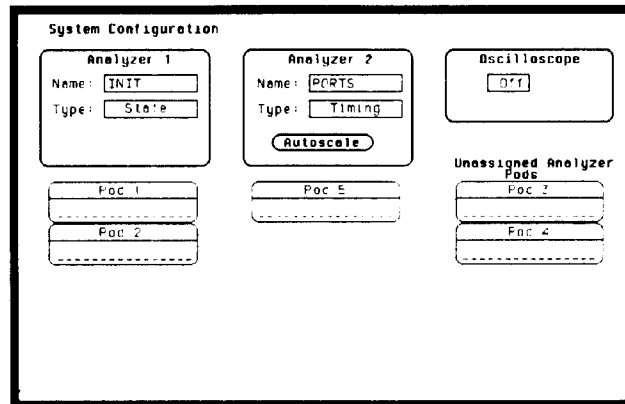

Figure 27-6. Re-configure System Configuration Menu

1. Select **Type** field in Analyzer 2.
2. Select the **Timing** field.

Connecting the Timing Analyzer Probes

At this point you would connect the probes of pod 5 as follows:

- Pod 5 bit 1 to enable line LINPT.
- Pod 5 bit 2 to enable line LOUTPT.
- Pod 5 bit 3 to enable line LDISP.
- Pod 5 bit 4 to enable line LSCAN.
- Pod 5 bit 5 to enable line LKEYBD.

Configuring the Timing Analyzer

Now that you have configured the system, you are ready to configure the timing analyzer. Configure the Timing Format Specification menu as shown below.

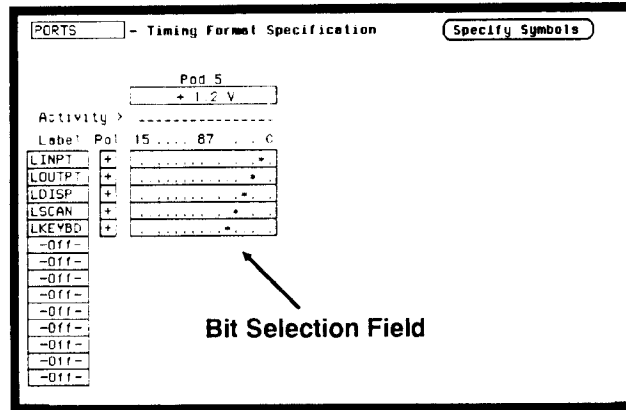

Figure 27-7. Configure the Timing Format Menu

1. Select the bit selection field.
2. Place the cursor on the appropriate bit and turn it on (asterisk *).

Setting the Timing Analyzer Trigger

Your timing measurement requires the timing analyzer to display the timing waveforms present on the enable lines when the routine is running. Since the state analyzer will trigger on address 0550, you will want to arm the timing analyzer with the state analyzer, so the timing waveforms will be captured at the same time.

Configure the Timing Trace Specification menu as shown below.

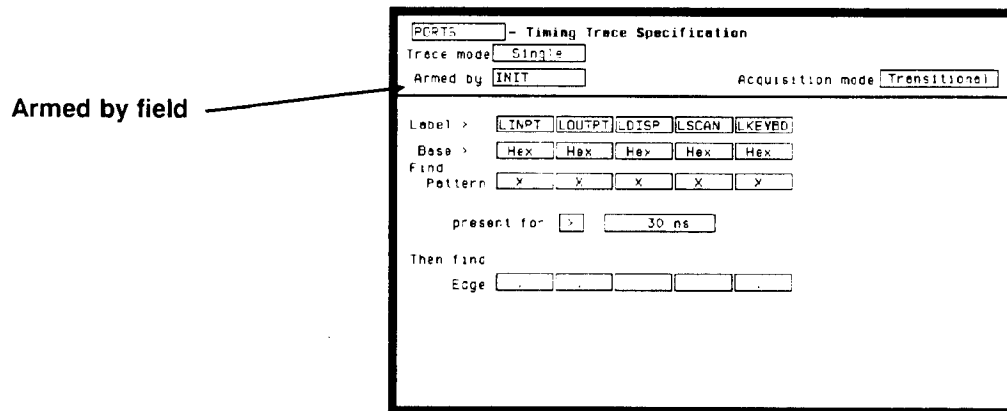

Figure 27-8. Set Armed By Field to INIT

1. Display the Timing Trace Specification menu.
2. Select the **Armed by** field.
3. Select the **INIT** (state analyzer) option in the pop-up.

Time Correlating the Data

In order to time correlate the data, the logic analyzer must store the timing relationships between states. Since the timing analyzer samples asynchronously and the state analyzer samples synchronously, the logic analyzer must use the stored timing relationship of the data to reconstruct a time correlated display.

Configure the State Trace Specification menu as shown below:

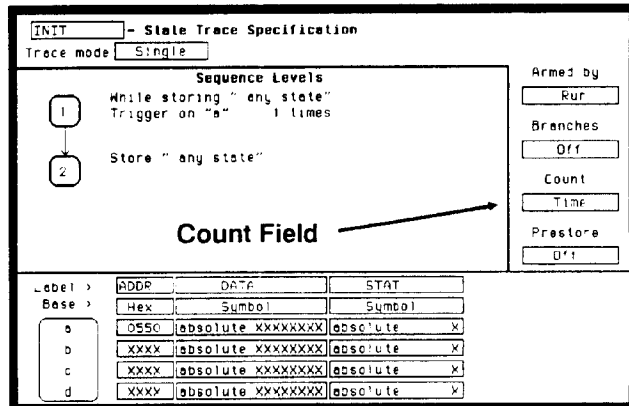

Figure 27-9. Set Count to Time

1. Display the State Trace Specification menu.
2. Select the **Count** field.
3. Select the **Time** field and press the SELECT key. The counter will now be able to keep track of time between states, for the time correlation.

Re-Acquiring the Data

With the timing analyzer configured and the probes of pod 5 connected to the circuit, all you have to do is press RUN. When the logic analyzer acquires the data it switches the display automatically to the Timing Waveforms menu, unless you switched to one of the other menus in the state analyzer after reconfiguring the Timing Trace menu. In that case, you will be in the State Listing menu. Regardless of which analyzer display menu you are in, you should now look at both analyzers together in the Mixed Mode Display.

Mixed Mode Display

The Mixed mode display shows you both the State Listing and Timing Waveforms menus simultaneously. To change the display to the Mixed Mode:

1. Select the field in the upper left corner of the display and press the SELECT key.
2. Select the **Mixed mode** field. You will now see the Mixed Mode display as shown below.

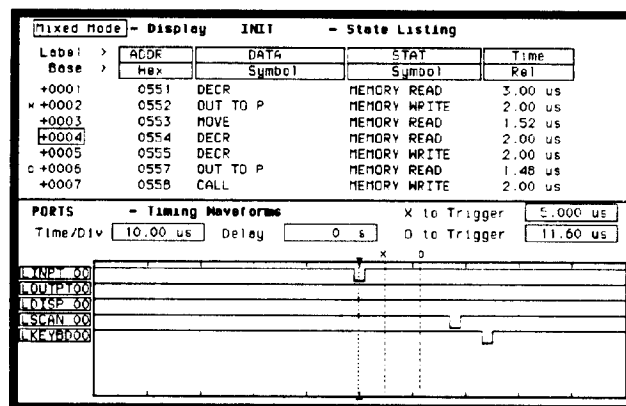

Figure 27-10. Mixed Mode Display

Interpreting the Display

In the Mixed Mode display the state listing is in the top half of the screen and the timing waveforms are in the lower half. The important thing to remember is that you time correlated this display so you could see what is happening in timing during the initialization routine.

Notice that the trigger point in both parts of the display is the same as it was when the displays were separate. The trigger in the state listing is at state + 0000 and the trigger of the timing waveform is the vertical dotted line.

As you look at the Mixed Mode Display, you notice that two of the five sequential enable pulses are missing on the timing waveforms display. This is the problem you are looking for, but you still don't have enough information about what might be causing these two enable lines to be inactive. This is where a closer look with the scope may help.

Re-configure the Analyzer with Scope

The two missing enable signals from the Timing Waveforms display show you where to look next. Before a pulse can be displayed, the voltage level must meet the threshold voltage requirements. To look at these enable lines closer, for a more detailed analysis of their voltage levels or any possible shorts or opens, you will use the oscilloscope.

Your measurement then requires the verification of the following:

- Signal voltage levels.
- Any possible shorted or open conditions.

Go back to the System Configuration menu and turn the Oscilloscope On as shown below.

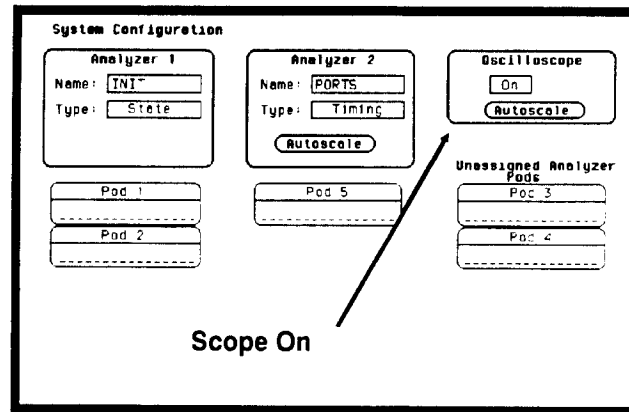

Figure 27-11. Re-configure with Scope

Connecting the Scope Probes

Connect the scope probes to the two enable lines that show missing signals.

Channel one is connected to LOUTPT.
Channel two is connected to LDISP.

Arming the Scope

Before the scope signals can be time-correlated and combined with the Timing Waveforms display, the scope must be armed by the timing analyzer and set to trigger immediately.

Set the **Armed by** field and **Mode** field in the Trigger menu as shown below.

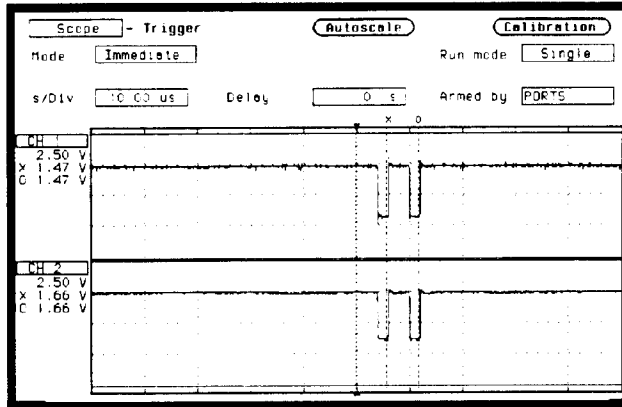

Figure 27-12. Set Armed by Field to PORTS

1. From the System Configuration menu, press the TRIG key. If you don't go to the scope Trigger menu, just select the upper left-most field and from there you can select the **Scope** field.
2. From the scope Trigger menu select the **Armed by** field.
3. From the pop-up select the **PORTS** field.
4. Select the **Mode** field and toggle to **Immediate**.

Making the Scope Measurement

With the scope armed by PORTS (timing analyzer) and the probes connected to LOUTPT and LDISP enable lines, all you have to do is select **RUN**. The scope will automatically switch to the Waveforms display.

The state analyzer cross triggers the timing analyzer, which in turn, triggers the oscilloscope.

Set the s/Div to $10\ \mu\text{s}$ and notice the double pulse and the voltage levels in the figure below.

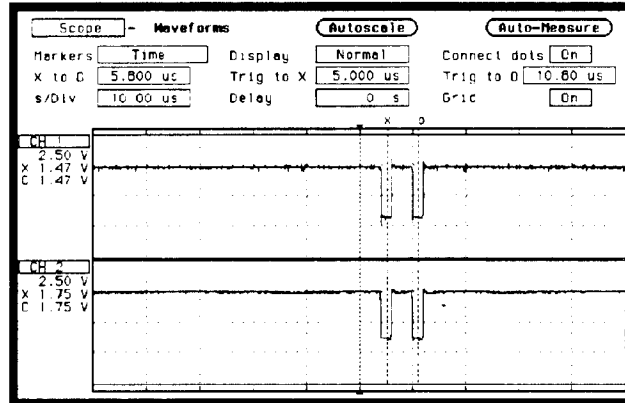

Figure 27-13. Scope Waveforms Display

You can examine the two enable lines in three different displays:

- Scope Waveforms.
- Timing Waveforms (scope channels can be added in).
- Mixed Mode Display.

Mixed Mode Display with Scope

With three different measurements stored in memory, you can now get the total picture of your problem from the Mixed Mode display. As mentioned before, the scope must be armed by the timing analyzer and set to trigger Immediate before the time-correlated scope signals can be inserted into the Timing Waveforms display

Insert the scope waveforms into the Timing Waveforms display (the lower display in Mixed Mode) as shown below.

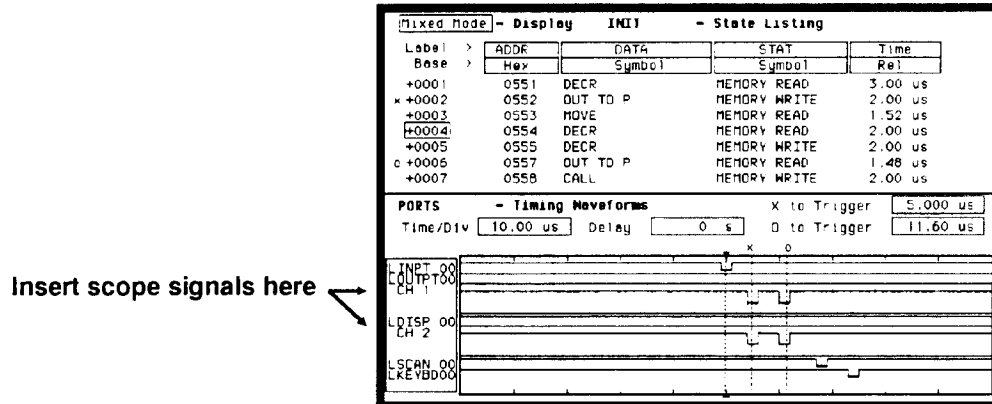

Figure 27-14. Mixed Mode Display

1. Select the upper-left most field and press the SELECT key.
2. From the pop-up select the **Mixed Mode** field.
3. From the Mixed Mode display menu, select the **LOUTPT** field and insert the scope's **CH 1** waveform. The waveform should appear directly below LOUTPT.
4. Select the **LDISP** field and insert the scope's **CH 2** waveform. The waveform should appear directly below LDISP.

Finding the Answer

You notice two double pulses instead of two sequential pulses. Since they are identical, this could mean a short between them. Also, the voltage levels never falls below threshold voltage of the timing analyzer. This is why the pulses were not displayed by the timing analyzer. After futher examination of the pc board, you find a solder bridge shorting the two enable signals together.

Summary

You have just learned how to use the timing and state analyzers interactively with the oscilloscope to find a problem that was not easily determined whether it was a software or hardware problem.

You have learned to do the following:

- Trigger one analyzer with the other.
- Time correlate measurement data.
- Interpret the Mixed mode display.

With three different measurements, time-correlated and displayed side by side, a complete analysis of this problem is done with the HP 1652B.

Microprocessor Specific Measurements

Introduction

This appendix contains information about the optional accessories available for microprocessor specific measurements. In depth measurement descriptions are included in the operating notes that come with each of these accessories. The accessories you will be introduced to in this appendix are the preprocessor modules and the HP 10269C General Purpose Probe Interface.

Microprocessor Measurements

A preprocessor module enables you to quickly and easily connect the logic analyzer to your microprocessor under test. Most of the preprocessor modules require the HP 10269C General Purpose Probe Interface. The preprocessor descriptions in the following sections indicate which preprocessors require it.

Included with each preprocessor module is a 3.5-inch disk which contains a configuration file and an inverse assembler file. When you load the configuration file, it configures the logic analyzer for making state measurements on the microprocessor for which the preprocessor is designed. It also loads in the inverse assembler file.

The inverse assembler file is a software routine that will display captured information in a specific microprocessor's mnemonics. The DATA field in the State Listing is replaced with an inverse assembly field (see Figure A-1). The inverse assembler software is designed to provide a display that closely resembles the original assembly language listing of the microprocessor's software. It also identifies the microprocessor bus cycles captured, such as Memory Read, Interrupt Acknowledge, or I/O write.

Label >	ADDR	68000 Mnemonic	Time	STAT
Base >	Hex	hex	Rel	Hex
-0002	0004F4	ORI.B #30,00		28
-0001	0004F6	B930 program read	1.24 us	28
+0000	008930	CHP.B #FF,0C	1.28 us	30
+0001	008932	00FF program read	1.24 us	30
+0002	008934	BEQ.B 00892E	1.24 us	30
+0003	008936	CHP.B ***,0C	1.24 us	30
+0004	00892E	BSR.B 00892A	1.76 us	30
+0005	008930	B03C unused prefetch	1.24 us	30
+0006	0004F4	-0000 program write	2.00 us	29
+0007	0004F6	B930 program write	1.48 us	29
+0008	00892A	JMP 0088C6(PC)	1.28 us	30
+0009	00892C	FF9A program read	1.24 us	30
+0010	0088C6	BSR.B 0088AE	1.72 us	30
+0011	0088C8	B03C unused prefetch	1.28 us	30

Figure A-1. State Listing with Mnemonics

Microprocessors Supported by Preprocessors

This section lists the microprocessors that are supported by Hewlett-Packard preprocessors and the logic analyzer model that each preprocessor requires. Most of the preprocessors require the HP 10269C General Purpose Probe Interface. The HP 10269C accepts the specific preprocessor PC board and connects it to five connectors on the general purpose interface to which the logic analyzer probe cables connect.



This appendix lists the preprocessors available at the time of printing. However, new preprocessors may become available as new microprocessors are introduced. Check with the nearest Hewlett-Packard sales office periodically for availability of new preprocessors.

Z80 CPU Package: 40-pin DIP

Accessories Required: HP 10300B Preprocessor
HP 10269C General Purpose Probe Interface

Maximum Clock Speed: 10 MHz clock input

Signal Line Loading: Maximum of one 74LS TTL load + 35 pF on
any line

Microprocessor Cycles Identified: Memory read/write
I/O read/write
Opcode fetch
Interrupt acknowledge
RAM refresh cycles

Maximum Power Required: 0.3 A at + 5 Vdc, supplied by logic
analyzer

Logic Analyzer Required: HP 1652B or HP 1653B

Number of Probes Used: Two 16-channel probes

NSC 800 CPU Package: 40-pin DIP

Accessories Required: HP 10303B Preprocessor
HP 10269C General Purpose Probe Interface

Maximum Clock Speed: 4 MHz clock input

Signal Line Loading: Maximum of one HCMOS load + 35 pF on any
line

Microprocessor Cycles Identified: Memory read/write
I/O read/write
Opcode fetch
Interrupt acknowledge
RAM refresh cycles
DMA cycles

Maximum Power Required: 0.1A at + 5 Vdc, supplied by logic
analyzer

Logic Analyzer Required: HP 1652B or HP 1653B

Number of Probes Used: Two 16-channel probes

8085 CPU Package: 40-pin DIP

Accessories Required: HP 10304B Preprocessor
HP 10269C General Purpose Probe Interface

Maximum Clock Speed: 6 MHz clock output (12 MHz clock input)

Signal Line Loading: Maximum of one 74LS TTL load + 35 pF on any
line

Microprocessor Cycle Identified: Memory read/write
I/O read/write
Opcode fetch
Interrupt acknowledge

Maximum Power Required: 0.8 A at + 5 Vdc, supplied by logic
analyzer

Logic Analyzer Required: HP 1652B or HP 1653B

Number of Probes Used: Two 16-channel probes

8086 or 8088 CPU Package: 40-pin DIP

Accessories Required: HP 10305B Preprocessor
HP 10269C General Purpose Probe Interface

Maximum Clock Speed: 10 MHz clock input (at CLK)

Signal Line Loading: Maximum of two 74ALS TTL loads + 40 pF on any line

Microprocessor Cycles Identified: Memory read/write
I/O read/write
Code fetch
Interrupt acknowledge
Halt acknowledge
Transfer to 8087 or 8089
co-processors

Additional Capabilities: The 8086 or 8088 can be operating in Minimum or Maximum modes. The logic analyzer can capture all bus cycles (including prefetches) or can capture only executed instructions. To capture only executed instructions, the 8086 or 8088 must be operating in the Maximum mode.

Maximum Power Required: 1.0 A at + 5 Vdc, supplied by the logic analyzer

Logic Analyzer Required: HP 1652B

Number of Probes Used: Three 16-channel probes

80186 or 80C186 CPU Package: 68-pin PGA

Accessories Required: HP 10306G Preprocessor

Maximum Clock Speed: 12.5 MHz clock output (25 MHz clock input)

Signal Line Loading: Maximum of 100 k Ω + 18 pF on any line

Microprocessor Cycles Identified: Memory read/write (DMA and non-DMA)
I/O read/write (DMA and non-DMA)
Code fetch
Interrupt acknowledge
Halt acknowledge
Transfer to 8087, 8089,
or 82586 co-processors

Additional Capabilities: The 80186 can be operating in Normal or Queue Status modes. The logic analyzer can capture all bus cycles (including prefetches) or can capture only executed instructions.

Maximum Power Required: 0.08 A at + 5 Vdc, supplied system under test.

Logic Analyzer Required: HP 1652B

Number of Probes Used: Four 16-channel probes

80286 CPU Package: 68-contact LCC or 68-pin PGA

Accessories Required: HP 10312D Preprocessor
HP 10269C General Purpose Probe Interface

Maximum Clock Speed: 10 MHz clock output (20 MHz clock input)

Signal Line Loading: Maximum of two 74ALS TTL loads + 40 pF on any line

Microprocessor Cycles Identified: Memory read/write
I/O read/write
Code fetch
Interrupt acknowledge
Halt
Hold acknowledge
Lock
Transfer to 80287 co-processor

Additional Capabilities: The logic analyzer captures all bus cycles including prefetches

Maximum Power Required: 0.66 A at + 5 Vdc, supplied by logic analyzer. 80286 operating current from system under test.

Logic Analyzer Required: HP 1652B

Number of Probes Used: Three 16-channel probes

80386 CPU Package: 132-pin PGA

Accessories Required: HP 10314D Preprocessor
HP 10269C General Purpose Probe Interface

Maximum Clock Speed: 33 MHz clock output (66 MHz clock input)

Signal Line Loading: Maximum of two 74ALS TTL loads + 35 pF on any line

Microprocessor Cycles Identified: Memory read/write
I/O read/write
Code fetch
Interrupt acknowledge, type 0-255
Halt
Shutdown
Transfer to 8087, 80287, or 80387 co-processors

Additional Capabilities: The logic analyzer captures all bus cycles including prefetches

Maximum Power Required: 1.0 A at + 5 Vdc, supplied by logic analyzer

Logic Analyzer Required: HP 1652B

Number of Probes Used: Five 16-channel probes

6800 or 6802 CPU Package: 40-pin DIP

Accessories Required: HP 10307B Preprocessor
HP 10269C General Purpose Probe Interface

Maximum Clock Speed: 2 MHz clock input

Signal Line Loading: Maximum of 1 74LS TTL load + 35 pF on any line

Microprocessor Cycle Identified: Memory read/write
DMA read/write
Opcode fetch/operand
Subroutine enter/exit
System stack push/pull
Halt
Interrupt acknowledge
Interrupt or reset vector

Maximum Power Required: 0.8A at + 5 Vdc, supplied by logic analyzer

Logic Analyzer Required: HP 1652B or HP 1653B

Number of Probes Used: Two 16-channel probes

6809 or 6809E CPU Package: 40-pin DIP

Accessories Required: HP 10308B Preprocessor
HP 10269C General Purpose Probe Interface

Maximum Clock Speed: 2 MHz clock input

Signal Line Loading: Maximum of one 74ALS TTL load + 35 pF on any line

Microprocessor Cycles Identified: Memory read/write
DMA read/write
Opcode fetch/operand
Vector fetch
Halt
Interrupt

Additional Capabilities: The preprocessor can be adapted to 6809/09E systems that use a Memory Management Unit (MMU). This adaptation allows the capture of all address lines on a physical address bus up to 24 bits wide.

Maximum Power Required: 1.0 A at + 5 Vdc, supplied by logic analyzer

Logic Analyzer Required: HP 1652B or HP 1653B

Number of Probes Used: Two 16-channel probes

68008 CPU Package: 40-pin DIP

Accessories Required: HP 10310B Preprocessor
HP 10269C General Purpose Probe Interface

Maximum Clock Speed: 10 MHz clock input

Signal Line Loading: Maximum of one 74S TTL load + one 74F TTL
load + 35 pF on any line

Microprocessor Cycles Identified: User data read/write
User program read
Supervisor read/write
Supervisor program read
Interrupt acknowledge
Bus grant
6800 cycle

Additional Capabilities: The logic analyzer captures all bus cycles
including prefetches

Maximum Power Required: 0.4 A at + 5 Vdc, supplied by logic
analyzer

Logic Analyzer Required: HP 1652B

Number of Probes Used: Three 16-channel probes

68000 and 68010 CPU Package: 64-pin DIP
(64-pin DIP)

Accessories Required: HP 10311B Preprocessor
HP 10269C General Purpose Probe Interface

Maximum Clock Speed: 12.5 MHz clock input

Signal Line Loading: Maximum of one 74S TTL load + one 74F
TTL load + 35 pF on any line

Microprocessor Cycles Identified: User data read/write
User program read
Supervisor read/write
Supervisor program read
Interrupt acknowledge
Bus Grant
6800 cycle

Additional Capabilities: The logic analyzer captures all bus cycles
including prefetches

Maximum Power Required: 0.4 A at + 5 Vdc, supplied by the logic
analyzer

Logic Analyzer Required: HP 1652B

Number of Probes Used: Three 16-channel probes

68000 and 68010 CPU Package: 68-pin PGA
(68-pin PGA)

Accessories Required: HP 10311G Preprocessor

Maximum Clock Speed: 12.5 MHz clock input

Signal Line Loading: 100 k Ω + 10 pF on any line

Microprocessor Cycles Identified: User data read/write
User program read
Supervisor read/write
Supervisor program read
Interrupt acknowledge
Bus Grant
6800 cycle

Additional Capabilities: The logic analyzer captures all bus cycles including prefetches.

Maximum Power Required: None

Logic Analyzer Required: HP 1652B

Number of Probes Used: Three 16-channel probes

68020 CPU Package: 114-pin PGA

Accessories Required: HP 10313G

Maximum Clock Speed: 25 MHz clock input

Signal Line Loading: 100 k Ω + 10 pF on any line

Microprocessor Cycles Identified: User data read/write
User program read
Supervisor read/write
Supervisor program read
Bus Grant
CPU space accesses including:
Breakpoint acknowledge
Access level control
Coprocesor communication
Interrupt acknowledge

Additional Capabilities: The logic analyzer captures all bus cycles including prefetches. The 68020 microprocessor must be operating with the internal cache memory disabled for the logic analyzer to provide inverse assembly.

Maximum Power Required: None

Logic Analyzer Required: HP 1652B

Number of Probes Used: Five 16-channel probes

68030 CPU Package: 128-pin PGA

Accessories Required: HP 10316G

Maximum Clock Speed: 25 MHz input

Signal Line Loading: 100K Ω plus 18 pF on all lines except DSACK0 and DSACK1.

Microprocessor Cycles Identified: User data read/write
User program read
Supervisor program read
Bus grant
CPU space accesses including:

Breakpoint acknowledge
Access level control
Coprocesor communication
Interrupt acknowledge

Additional Capabilities: The logic analyzer captures all bus cycles, including prefetches. The 68030 microprocessor must be operating with the internal cache memory and MMU disabled for the logic analyzer to provide inverse assembly.

Maximum Power Required: None

Logic Analyzer Required: HP 1652B

Number of Probes Used: Five 16-channel probes

68HC11 CPU Package: 48-pin dual-in-line

Accessories Required: HP 10315G

Maximum Clock Speed: 8.4 MHz input

Signal Line Loading: 100K Ω plus 12 pF on all lines.

Microprocessor Cycles Identified: Data read/write
 Opcode/operand fetches
 Index offsets
 Branch offsets
 Irrelevant cycles

Additional Capabilities: The 68HC11 must be operating in the expanded multiplexed mode (addressing external memory and/or peripheral devices) for the logic analyzer to provide inverse assembly.

Maximum Power Required: None

Logic Analyzer Required: HP 1652B or HP1553B

Number of Probes Used: Two 16-channel probes for state analysis and one to four for timing analysis.

Loading Inverse Assembler Files

You load the inverse assembler file by loading the appropriate configuration file. Loading the configuration file automatically loads the inverse assembler file.

Selecting the Correct File

Most inverse assembler disks contain more than one file. Each disk usually contains an inverse assembler file for use with the HP 10269C and preprocessor as well as a file for general purpose probing. Each inverse assembler filename has a suffix which indicates whether it is for the HP 10269C and preprocessor or general purpose probing. For example, filename C68000_I indicates a 68000 inverse assembler file for use with the HP 10269C and the 68000 preprocessor. Filename C68000_P is for general purpose probing. Specific file descriptions and recommended usage are contained in each preprocessor operating note.

Loading the Desired File

To load the inverse assembler file you want, insert the 3.5-inch disk you received with your preprocessor in the disk drive. Select the I/O menu. In the I/O menu, select DISK OPERATIONS. The logic analyzer will read the disk and display the disk directory.

Select the Load option and place the filename you want to load in the "from file" box. Place the cursor on Execute and press SELECT.

Place the cursor on the analyzer you want the file loaded into and press SELECT. An advisory "Loading file from disk" is displayed. When the logic analyzer has finished loading the file, you will see "Load operation complete."

The file is now loaded and the logic analyzer is configured for disassembly of acquired data.

Connecting the Logic Analyzer Probes

The specific preprocessor and inverse assembler you are using determines how you connect the logic analyzer probes. Since the inverse assembler files configure the System Configuration, State Format Specification, and State Trace Specification menus, you must connect the logic analyzer probe cables accordingly so that the acquired data is properly grouped for inverse assembly. Refer to the specific inverse assembler operating note for the proper connections.

How to Display Inverse Assembled Data

The specific preprocessor and inverse assembler you are using determines how the inverse assembled data is displayed. When you press RUN, the logic analyzer acquires data and displays the State Listing menu.

The State Listing menu will display as much information about the captured data as possible. For some microprocessors, the display will show a completely disassembled state listing.

Some of the preprocessors and/or the microprocessors under test do not provide enough status information to disassemble the data correctly. In this case, you will need to specify additional information (i.e., tell the logic analyzer what state contains the first word of an opcode fetch). When this is necessary an additional field (INVASM) will appear in the top center of the State Listing menu (see below). This field allows you to point to the first state of an Op Code fetch.

```
68000STATE - State Listing Invasm Minimum X-0: 0 s
Markers Statistics Valid runs: Maximum X-0: 0 s
16 of 16 Average X-0: 0 s
```

Figure A-2. Inverse Assemble Field

For complete details refer to the Operating Note for the specific preprocessor.

Automatic Measurement Algorithms

Introduction

One of the HP 1652B/1653B's primary oscilloscope features is its ability to make parametric measurements. This appendix provides details on how automatic measurements are performed and some tips on how to improve automatic measurement results.

Measurement Setup

Measurements typically should be made at the fastest possible sweep speed to obtain the most measurement accuracy possible. For any measurement to be made, the portion of the waveform required for that measurement must be displayed on the oscilloscope:

- At least one complete cycle must be displayed for period or frequency measurements.
- The entire pulse must be displayed for pulse width measurements.
- The leading (rising) edge of the waveform must be displayed for risetime measurements.
- The trailing (falling) edge of the waveform must be displayed for falltime measurements.

Making Measurements

If more than one waveform, edge, or pulse is displayed, the measurements are made on the first (leftmost) portion of the displayed waveform that can be used. When any of the defined measurements are requested, the oscilloscope first determines the top (100%) and base (0%) voltages of the waveform. From this information, it can determine the other important voltage values (10% voltage, 90% voltage, and 50% voltage) required to make the measurements. The 10% and 90% voltage values are used in the risetime and falltime measurements. The 50% voltage value is used for measuring frequency, period, pulse width, and duty cycle.

Top and Base Voltages

All measurements except V_{p-p} are calculated using the V_{top} (100% voltage) and V_{base} (0% voltage) levels of the displayed waveform. The V_{top} and V_{base} levels are determined from an occurrence density histogram of the data points displayed on screen.

The digitizing oscilloscope displays 6-bit vertical voltage resolution. This means the vertical display is divided up into 64 voltage levels. Each of these 64 levels is called a quantization level. Each waveform has a minimum of 500 data points displayed horizontally on screen. Each of these data point sets have one quantization level assigned to it. The histogram is calculated by adding the number of occurrences of each quantization level of the displayed data point sets on the displayed waveform.

The quantization level with the greatest number of occurrences in the top half of the waveform corresponds to the V_{top} level. The quantization level with the greatest number of occurrences in the bottom half of the waveform corresponds to the V_{base} level.

If V_{top} and V_{base} do not contain at least 5% of the minimum (500) data points displayed on screen, V_{top} defaults to the maximum voltage ($V_{maximum}$) and V_{base} defaults to the minimum voltage ($V_{minimum}$) found on the display. An example of this case would be measurements made on sine or triangle waves.

From this information the instrument can determine the 10, 50, and 90% points, which are used in most automatic measurements. The V_{top} or V_{base} of the waveform is not necessarily the maximum or minimum voltage present on the waveform. If a pulse has a slight amount of overshoot, it would be wrong to select the highest peak of the waveform as the top since the waveform normally rests below the perturbation.

Measurement Algorithms

The following is a condensed explanation of the automatic measurements discussed in chapter 25.

Frequency (Freq) The frequency of the first complete cycle displayed is measured using the 50% levels.

If the first edge on the display is rising then

$$\text{Freq} = 1/(\text{trising edge 2} - \text{trising edge 1})$$

If the first edge on the display is falling then

$$\text{Freq} = 1/(\text{tfalling edge 2} - \text{tfalling edge 1})$$

Period The period is measured at the 50% voltage level of the waveform.

If the first edge on the display is rising then

$$\text{Period} = \text{trising edge 2} - \text{trising edge 1}$$

If the first edge on the display is falling then

$$\text{Period} = \text{tfalling edge 2} - \text{tfalling edge 1}$$

Peak-to-Peak Voltage (Vp_p) The maximum and minimum voltages for the selected source are measured.

$$V_{p_p} = V_{\text{maximum}} - V_{\text{minimum}}$$

where V_{maximum} and V_{minimum} are the maximum and minimum voltages present on the selected source.

Positive Pulse width (+Width)

Pulse width is measured at the 50% voltage level. If the first edge on the display is rising then

$$+ \text{Width} = t_{\text{falling edge 1}} - t_{\text{rising edge 1}}$$

If the first edge on the display is falling then

$$+ \text{Width} = t_{\text{falling edge 2}} - t_{\text{rising edge 1}}$$

Negative Pulse width (-Width)

Negative pulse width is the width of the first negative pulse on screen using the 50% levels.

If the first edge on the display is rising then

$$-\text{Width} = t_{\text{rising edge 2}} - t_{\text{falling edge 1}}$$

If the first edge on the display is falling then

$$-\text{Width} = t_{\text{rising edge 1}} - t_{\text{falling edge 1}}$$

Risetime

The risetime of the first displayed rising edge is measured. To obtain the best possible measurement accuracy, set the sweep speed as fast as possible while leaving the leading edge of the waveform on the display. The risetime is determined by measuring time at the 10% and 90% voltage points on the rising edge.

$$\text{Risetime} = t_{90\%} - t_{10\%}$$

Falltime

Falltime is measured between the 10% and 90% points of the falling edge. To obtain the best possible measurement accuracy, set the sweep speed as fast as possible while leaving the falling edge of the waveform on the display.

$$\text{Falltime} = t_{10\%} - t_{90\%}$$

Preshoot and Overshoot

Preshoot and Overshoot measure the perturbation on a waveform above or below the top and base voltages (see "Top and Base Voltages" section earlier in this appendix). These measurements use all data displayed on screen, therefore it is very important that only the data of interest be displayed. If you want to measure preshoot and overshoot on one edge of a waveform, then only display that edge. If you want to measure the maximum preshoot and overshoot on a waveform, then display several cycles of the waveform.

Preshoot is a perturbation before a rising or a falling edge and is measured as a percentage of the top-base voltage.

Overshoot is a perturbation after a rising or a falling edge and is measured as a percentage of the top-base voltage

If the measured edge is rising then

$$\text{Preshoot} = \left[\frac{V_{\text{base}} - V_{\text{minimum}}}{V_{\text{top-base}}} \right] \times 100$$

$$\text{Overshoot} = \left[\frac{V_{\text{maximum}} - V_{\text{top}}}{V_{\text{top-base}}} \right] \times 100$$

If the measured edge is falling then:

$$\text{Preshoot} = \left[\frac{V_{\text{maximum}} - V_{\text{top}}}{V_{\text{top-base}}} \right] \times 100$$

$$\text{Overshoot} = \left[\frac{V_{\text{base}} - V_{\text{minimum}}}{V_{\text{top-base}}} \right] \times 100$$

Duty Cycle The positive pulse width and the period of the displayed signal are measured.

$$\text{duty cycle} = (\text{pulse width} / \text{period}) \times 100$$

rms Voltage The rms voltage is computed over one complete period.

Average Voltage The average voltage of the first cycle of the displayed signal is measured. If a complete cycle is not present, the instrument will average the data points on screen.

Error Messages

Introduction

This appendix lists the error messages that require corrective action to restore proper operation of the logic analyzer. There are several messages that you will see that are merely advisories and are not listed here. For example, "Load operation complete" is one of these advisories.

The messages are listed in alphabetical order and in bold type.

Acquisition aborted. This message is displayed whenever data acquisition is stopped.

At least one edge is required. A state clock specification requires at least one clock edge. This message only occurs if you turn off all edges in the state clock specification.

Autoload file not of proper type. This message is displayed if any file other than an HP 1652B/1653B configuration file is specified for an autoload file and the logic analyzer is powered up.

Autoscale aborted. This message is displayed when the STOP key is pressed or if a signal is not found 15 seconds after the initiation of autoscale.

BNC is being used as an ARM IN and cannot be used as an ARM OUT. This message is displayed when BNC arms machine 1 (or 2), machine 1 (or 2) arms machine 2 (or 1), and the BNC is specified as ARM OUT. It will not occur if BNC arms machine 1 (or 2), and machine 1 (or 2) arms BNC.

Configuration not loaded. Indicates a bad configuration file. Try to reload the file again. If the configuration file will still not load, a new disk and/or configuration file is required.

Copy operation complete. Indicates the copy operation has either successfully completed or has been stopped.

Correlation counter overflow. The correlation counter overflows when the time from when one machine's trigger to the second machine's trigger exceeds the maximum count. It may be possible to add a "dummy" state to the second machine's trigger specification that is closer in time to the trigger of the first machine.

Data can not be correlated-Time count need to be turned on. "Count" must be set to "Time" in both machines to properly correlate the data.

Destination write protected-file not copied. Make sure you are trying to copy to the correct disk. If so, set the write protect tab to the non-protect position and repeat the copy operation.

File not copied to disc-check disc. The HP 1652B/1653B does not support track sparing. If a bad track is found, the disk is considered bad. If the disk has been formatted elsewhere with track sparing, the HP 1652B/1653B will only read up to the first spared track.

Hardware ERROR: trace point in count block. Indicates the data from the last acquisition is not reliable and may have been caused by a hardware problem. Repeat the data acquisition to verify the condition. If this message re-appears, the logic analyzer requires the attention of service personnel.

Insufficient memory to load IAL - load aborted. This message indicates that there is not a block of free memory large enough for the inverse assembler you are attempting to load even though there may be enough memory in several smaller blocks. Try to load the inverse assembler again. If this load is unsuccessful, load the configuration and inverse assembler separately.

Invalid file name. Check the file name. A file name must start with an alpha character and cannot contain spaces or slashes (/).

Inverse assembler not loaded-bad object code. Indicates a bad inverse assembler file on the disc. A new disc or file is required.

Maximum of 32 channels per label. Indicates an attempt to assign more than 32 channels to a label. Reassign channels so that no more than 32 are assigned to a label.

No room on destination-file not copied. Indicates the destination disc doesn't have enough room for the file you are attempting to copy. Try packing the disc and repeating the copy operation. If this is unsuccessful, you will need to use a different disc.

(x) Occurrences Remaining in Sequence. Indicates the logic analyzer is waiting for (x) number of occurrences in a sequence level of the trigger specification before it can go on to the next sequence level.

PRINT has been stopped. This message appears when the print operation has been stopped.

(x) Secs Remaining in Trace. Indicates the amount of time remaining until acquisition is complete in Glitch mode.

Search failed - O pattern not found. Indicates the O pattern does not exist in the acquired data. Check for a correct O marker pattern specification.

Search failed - X pattern not found. Indicates the X pattern does not exist in the acquired data. Check for a correct X marker pattern specification.

Slow Clock or Waiting for Arm. Indicates the state analyzer is waiting for a clock or arm from the other machine. Recheck the state clock or arming specification.

Slow or missing Clock. Indicates the state analyzer has not recognized a clock for 100 ms. Check for a missing clock if the intended clock is faster than 100 ms. If clock is present but is slower than 100 ms, the data will still be acquired when a clock is recognized and should be valid.

Specified inverse assembler not found. Indicates the inverse assembler specified cannot be found on the disk.

State clock violates overdrive specification. Indicates the data from the last acquisition is not reliable due to the state clock signal not being reliable. Check the clock threshold for proper setting and the probes for proper grounding.

States Remaining to Post Store. Indicates the number of states required until memory is filled and acquisition is complete.

Time count need to be turned on. This message appears when the logic analyzer attempts to time correlate data and "Count" is not set to "Time."

Transitions Remaining to Post Store. Indicates the number of transitions required until memory is filled and acquisition is complete.

Unsupported destination format-file not copied. Indicates the disk you have attempted to copy to is either not formatted or formatted in a format not used by the logic analyzer. Format the disk or use a properly formatted disk and repeat the copy operation.

Value out of range. Set to limit. Indicates an attempt to enter a value that is out of range for the specific variable. The logic analyzer will set the value to the limit of the variable range automatically.

Waiting for Arm. Indicates the arming condition has not occurred.

Waiting for Prestore. Indicates the prestore condition has not occurred.

Waiting for Trigger. Indicates the trigger condition has not occurred.

Warning: Chips not successfully running. Indicates the acquisition chips in the logic analyzer are not running properly. Press STOP and then RUN again. If the warning message reappears, refer the logic analyzer to service personnel.

Warning: Chips not successfully stopped. Indicates the acquisition chips in the logic analyzer are not stopping properly. Press RUN and then STOP again. If the warning message reappears, refer the logic analyzer to service personnel.

Warning: Duplicate label name. Indicates an attempt to assign an existing name to a new label.

Warning: Duplicate symbol name. Indicates an attempt to assign an existing name to a new symbol.

Warning: Invalid file type. Indicates an attempt to load an invalid file type. For example, the SYSTEM file can only be loaded on power-up and if you attempt to load it from the I/O menu, this message will appear.

Warning: No clock edge in other clock, add clock edge. This message only occurs in a state analyzer using mixed or demultiplexed clocks. It indicates there is no edge specified in either the master or slave clock. There must be at least one edge in each of the clocks.

Warning: Symbol memory full. Max 200 symbols. Indicates an attempt to store more than 200 symbols.

Warning: Run HALTED due to variable change. Indicates a variable has been changed during data acquisition in the continuous trace mode. The data acquisition will be halted and this message will be displayed when any variable affecting the system configuration, clock thresholds, clock multiplexing, or trace specification menus is changed during data acquisition.

Installation, Maintenance and Calibration

Introduction

This appendix contains information and instructions necessary for preparing the HP 1652B/1653B Logic Analyzers for use. Included in this section are inspection procedures, power requirements packaging information, and operating environment. It also tells you how to load the operating system and turn the logic analyzer on. Also included in this appendix is information on calibration and maintenance that you can do as an operator.

Initial Inspection

Inspect the shipping container for damage. If the shipping container or cushioning material is damaged, it should be kept until the contents of the shipment have been checked for completeness and the instrument has been checked mechanically and electrically. Accessories supplied with the instrument are listed under "Accessories Supplied" in chapter 1 of this manual. An overview of the self-test procedure is in Appendix E of this manual. The complete details of the procedure are in Chapter 6 of the Service manual. Electrical performance verification functions are also in Chapter 3 of the Service Manual.

If the contents are incomplete, if there is mechanical damage or defect, or if the instrument does not pass the Self Test Performance Verification, notify the nearest Hewlett-Packard Office. If the shipping container is damaged, or the cushioning materials show signs of stress, notify the carrier as well as the Hewlett-Packard Office. Keep all shipping materials for the carrier's inspection. The Hewlett-Packard office will arrange for repair or replacement at HP option without waiting for claim settlement.

Operating Environment

You may operate your logic analyzer in a normal lab or office type environment without any additional considerations. If you intend to use it in another type of environment, refer to Appendix F for complete operating environment specifications. Note the humidity limitation. Condensation within the instrument cabinet can cause poor operation or malfunction. Protection should be provided against temperature extremes which cause condensation.

Ventilation

You must provide an unrestricted airflow for the fan and ventilation openings in the rear of the logic analyzer. However, you may stack the logic analyzer under, over, or in-between other instruments as long the surfaces of the other instruments are not needed for their ventilation.

Storage and Shipping

This instrument may be stored or shipped in environments within the following limitations:

- Temperature: - 40 ° C to + 75 ° C
- Humidity: Up to 90% at 65 ° C
- Altitude: Up to 15,300 metres (50,000 feet)

Tagging for Service

If the instrument is to be shipped to a Hewlett-Packard office for service or repair, attach a tag to the instrument identifying owner address of owner, complete instrument model and serial numbers and a description of the service required.

Original Packaging

If the original packaging material is unavailable or unserviceable materials identical to those used in factory packaging are available through Hewlett-Packard offices. If the instrument is to be shipped to a Hewlett-Packard office for service, tag the instrument (see "Tagging for Service"). Mark the container FRAGILE to ensure careful handling. In any correspondence, refer to the instrument by model number and full serial number.

Other Packaging The following general instructions should be followed for repacking with commercially available materials.

- a. Wrap the instrument in heavy paper or plastic.
- b. Use a strong shipping container. A double-wall carton made of 350 lb. test material is adequate.
- c. Use a layer of shock-absorbing material 70 to 100 mm (3 to 4 inches) thick around all sides of the instrument to firmly cushion and prevent movement inside the container. Protect the control panel with cardboard.
- d. Seal the shipping container securely.
- e. Mark the shipping container **FRAGILE** to ensure careful handling.
- f. In any correspondence, refer to the instrument by model number and full serial number.

**Power
Requirements**









The HP 1652B/53B requires a power source of either 115 or 230 Vac -22% to $+10\%$; single phase, 48 to 66 Hz; 200 Watts maximum power.

Power Cable

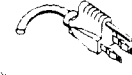
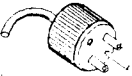
This instrument is provided with a three-wire power cable. When connected to an appropriate AC power outlet, this cable grounds the instrument cabinet. The type of power cable plug shipped with the instrument depends on the country of destination. Refer to Table D-1 for power plugs and HP part numbers for the available plug configurations.

Warning

BEFORE CONNECTING THIS INSTRUMENT, the protective earth terminal of the instrument must be connected to the protective conductor of the (Mains) power cord. The Mains plug must be inserted in a socket outlet provided with a protective earth contact. The protective action must not be negated by the use of an extension cord (power cable) without a protective conductor (grounding). Grounding one conductor of a two conductor outlet does not provide an instrument ground.

PLUG TYPE	CABLE PART NO.	PLUG DESCRIPTION	LENGTH IN/CM	COLOR	COUNTRY
OPT 900  250V	8120-1351 8120-1703	Straight *BS1363A 90°	90/228 90/228	Gray Mint Gray	United Kingdom, Cyprus, Nigeria, Zimbabwe, Singapore
OPT 901  250V	8120-1369 8120-0696	Straight *NZSS188/ASC 90°	79/200 87/221	Gray Mint Gray	Australia New Zealand
OPT 902  250V	8120-1689 8120-1692 8120-2857	Straight *CEE7-Y11 90° Straight (Shielded)	79/200 79/200 79/200	Mint Gray Mint Gray Coco Brown	East and West Europe, Saudi Arabia, S. Africa, India (Unpolarized In many nations)
OPT 903**  125v	8120-1378 8120-1521 8120-1992	Straight *NEMA5-15P 90° Straight (Medical) UL544	90/228 90/228 96/244	Jade Gray Jade Gray Black	United States, Canada, Mexico, Philippines, Taiwan
OPT 904**  250v	8120-0698	Straight *NEMA6-15P	90/228	Black	United States, Canada
OPT 905  250V	8120-1396 8120-1625	CEE22-V1 (System Cabinet Use) 250V	36/76 96/244	Jade Gray	For interconnecting system components and peripherals United States and Canada only
OPT 906  250v	8120-2104 8120-2296	Straight *SEV1011 1959-24507 Type 12 90°	79/200 79/200	Mint Gray Mint Gray	Switzerland
OPT 912  220V	8120-2956 8120-2957	Straight *DHCK107 90°	79/200 79/200	Mint Gray Mint Gray	Denmark
OPT 917  250V	8120-4211 8120-4600	Straight *SABS164 90°	79/200 79/200	Jade Gray	Republic of South Africa, India
OPT 918  100V	8120-4753 8120-4754	Straight Mits 90°	90/230 90/230	Dark Gray	Japan

Rev. 11/19/98
*Part number shown for plug is industry identifier for plug only. Number shown for cable is HP part number for complete cable including plug.
**These cords are included in the CSA certification approval of the equipment.
E=Earth/Ground
L=Line
N=Neutral

Table D-1. Power Cord Configurations

Removing Yellow Shipping Disk

Your logic analyzer is shipped with a protective yellow shipping disk in the disk drive. Before you can insert the operating system disk you must remove the yellow shipping disk. Press the disk eject button as shown in figure D-1. The yellow shipping disk will pop out part way so you can pull it out of the disk drive.

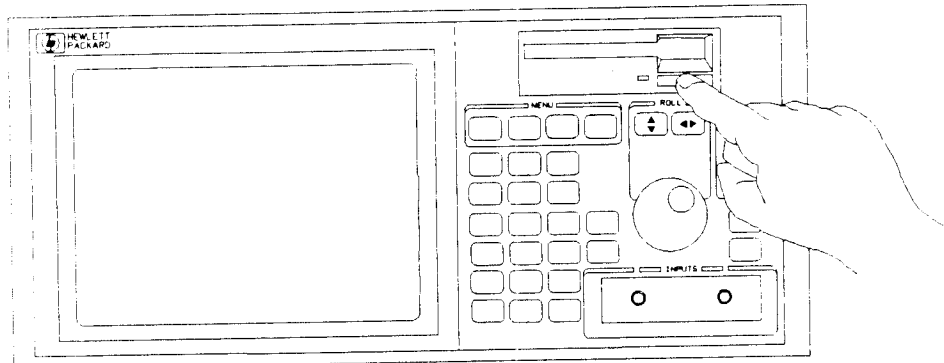

© 1995 HP

D-1. Removing Yellow Shipping Disk

Selecting the Line Voltage

The line voltage selector has been factory set to the line voltage used in your country. It is a good idea to check the setting of the line voltage selector so you become familiar with what it looks like. If the setting needs to be changed, follow the procedure in the next paragraph.



You can damage the logic analyzer if the module is not set to the correct position.

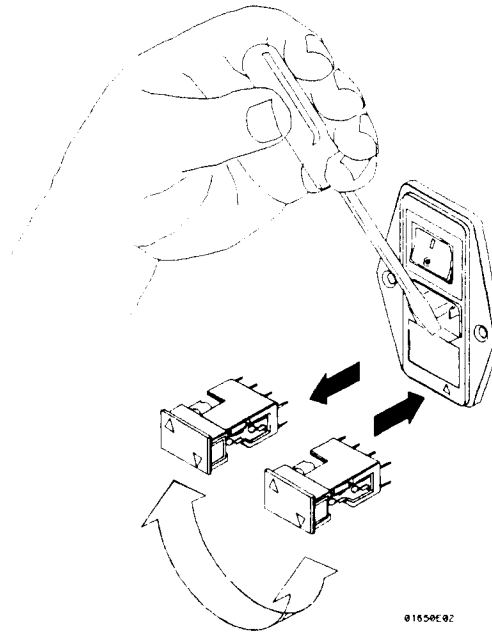

D-2. Selecting The Line Voltage

You change the proper line voltage by pulling the fuse module out and reinserting it with the proper arrows aligned. To remove the fuse module, carefully pry at the top center of the module (as shown) until you can grasp and pull it out by hand.

Checking for the Correct Fuse

If you find it necessary to check or change fuses, remove the fuse module and look at each fuse for its amperage and voltage. Refer to figure D-3 to locate the 115 V and 230 V fuse locations. To remove the fuse module, carefully pry at the top center of the module (see figure D-2) until you can grasp and pull it out by hand.

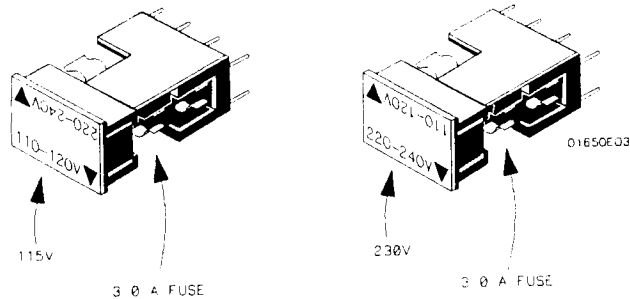

D-3. Checking For The Correct Fuse

Applying Power

When power is applied to the HP 1652B/1653B, a power-up self test will be performed automatically. For information on the power-up self test, refer to Appendix E and Section 3 of the Service Manual.

Loading the Operating System

Before you can operate the instrument, you must load the operating system from the operating system disk. You received two identical operating system disk. You should mark one of them Master and store it in a safe place. Mark the other one Work and use only the work copy. This will provide you with a back-up in case your work copy becomes corrupt.



To prevent damage to your operating system disk, **DO NOT** remove the disk from the disk drive while it is running. Only remove it after the indicator light has gone out.

Installing the Operating System Disk

To load the logic analyzer's operating system, you must install the disk as shown below before you turn on the power. When the disk snaps into place, the disk eject button pops out and you are ready to turn on the logic analyzer.

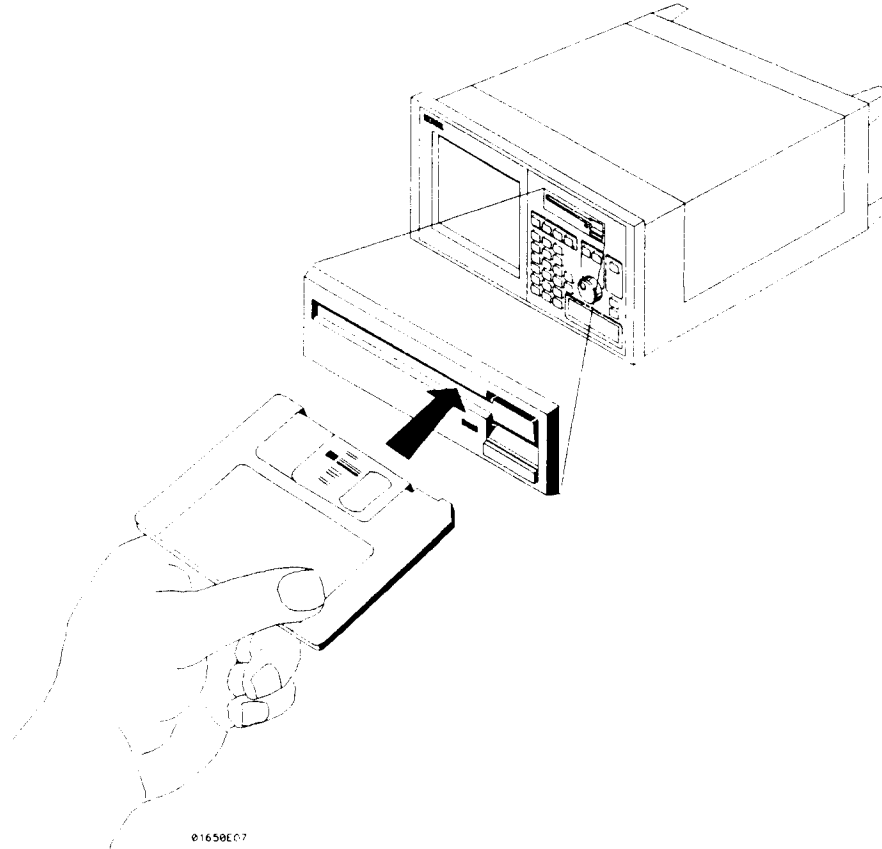

D-4. Installing The Operating System Disk

The logic analyzer will read the disk and load the operating system. It will also run self-tests before it is ready for you to operate.

Line Switch

The line switch is located on the rear panel. You turn the instrument on by pressing the 1 on the rocker switch. Make sure the operating system disk is in the disk drive before you turn on the logic analyzer. If you forget the disk, don't worry, you won't harm anything. You will merely have to repeat the turn-on procedure with the disk in the drive.

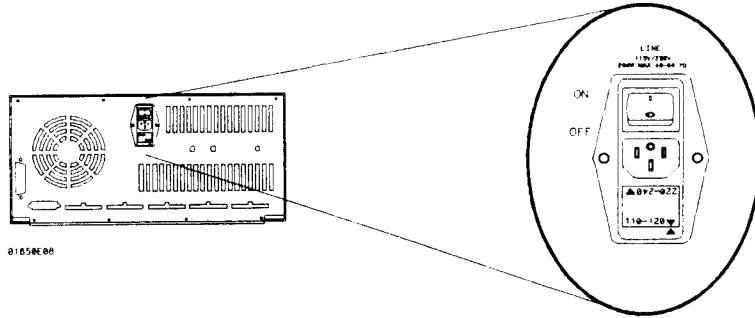

D-5. Line Switch

Intensity Control

Once you have turned the instrument on, you may want to set the display intensity to a level that's more comfortable for you. You do this by turning the INTENSITY control on the rear panel.

Note 

A high intensity level setting may shorten the life of the CRT in your instrument.

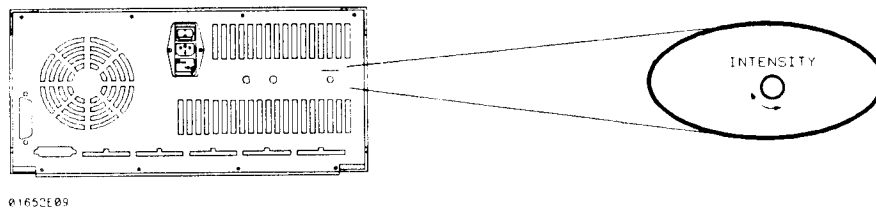

D-6. Intensity Control

Operator's Maintenance

The only maintenance you need to do is clean the instrument exterior and periodically check the rear panel for air restrictions.

Use only MILD SOAP and WATER to clean the cabinet and front panel. DO NOT use a harsh soap which will damage the water-base paint finish of the instrument.

Calibration

The oscilloscope software calibration is accessed through the oscilloscope Trigger menu. The calibration procedures are performed from the front panel and without need to access internal circuits.

Calibration Interval Software calibration should be performed if one of the following occurs:

- Oscilloscope board is installed, replaced or repaired.
- Ambient temperature changes more than 10° C.
- 6 months or 1000 hours of operation.

Calibration Integrity

Calibration constants are stored in system memory and not on the Operating System Disk. Therefore, software calibration is not required when a different Operating System Disk is used to boot the instrument on power-up.

Software Calibration Procedures

The following calibration procedures should be performed in their entirety and in the same sequence shown in this procedure. The following test equipment is recommended:

- BNC cable.
- DC Power Supply HP 6114A ($\pm 0.1\%$ accuracy).
- Digital Voltmeter HP 3478A ($\pm 0.025\%$ accuracy).
- BNC (female)-to-dual Banana Adapter.
- BNC -to-mini probe adapter



An instrument warm-up of 15 minutes is recommended before starting these procedures. To abort any calibration procedure, use the front-panel knob to select the **Cancel** field, then press the **SELECT** key.

Offset Calibration

1. In the **System Configuration** menu turn both State/Timing analyzers Off, and turn the oscilloscope On.
2. Press the **TRACE/TRIG** key and select the **Calibration** field using the front-panel knob and **SELECT** key.



Offset calibration should be the default Calibration menu setting. If not, select the Calibration choice field and, when the pop-up appears, select **Offset**.

3. Disconnect all signals from the channel 1 and 2 inputs. Select **Start** with the front-panel knob and **SELECT** key. A message will appear on screen to indicate the calibration is in process.
4. When the calibration is complete, the calibration status screen will appear.

Gain Calibration

11. Disconnect all test equipment and all inputs to channel 1 and 2 of the oscilloscope.
12. Select the Calibration choice field. When the pop-up appears, select **Gain**, then select **Start**.
13. When the calibration is complete, the updated calibration status screen will appear.

Trigger Calibration

14. Make sure all signals are disconnected from the channel 1 and 2 inputs of the oscilloscope.
15. Select the Calibration choice field. When the pop-up appears, select **Trigger level**, then select **Start**.
16. When the calibration is complete, the updated calibration status screen will appear.

Delay Calibration

17. Select the Calibration choice field. When the pop-up appears, select **Delay**, then select **Start**.
18. Connect a BNC cable from the Probe Compensation output on the rear panel, to the channel 1 input. The instrument will prompt you when you need to switch to channel 2.



You have the option of using the 10:1 scope probe in place of the recommended 1:1 BNC cable. If you use the scope probe, you will have to use the BNC-to-mini probe adapter supplied with the instrument and set attenuation field in *step 19* to 10:1.

19. Set the attenuation field in the calibration screen to the appropriate setting.

20. To proceed with the Delay calibration, select **Continue**.
21. When the calibration is complete, the updated calibration status screen will appear.
22. Calibration is now complete. Select **Done** with the front-panel knob and SELECT key to exit the Calibration menu.

Note 

Do not execute **Set to Default** after calibrating the instrument. Otherwise, your calibration factors will be replaced by default calibration factors.

Operator Self Tests

Introduction

This appendix gives you an overview of the self tests the logic analyzer runs when you turn it on. You can also access the self tests from the I/O menu. This appendix is not intended to provide service information, but to acquaint you with the tests. If service is required, it should be performed by qualified service personnel.

Self Tests

The power-up self test is a set of tests that are automatically performed when you apply power to the logic analyzer. You may perform the self tests individually to have a higher level of confidence that the instrument is operating properly. A message that the instrument has failed a test will appear if any problem is encountered during a test. The individual self tests are listed in the self test menu which is accessed via the I/O menu. The HP 1652B/1653B self tests are on the operating system disk and the disk is required to run the tests.

Power-up Self Test

The power-up self test is automatically initiated at power-up by the HP 1652B/1653B Logic Analyzers. The revision number of the operating system firmware is given in the upper right of the screen during the power-up self test. As each test is completed, either "passed" or "failed" will be displayed before the test name as shown below.

PERFORMING POWER-UP SELF TESTS

passed ROM test
passed RAM test
passed Interrupt test
passed Display test
passed Keyboard test
passed Acquisition test
passed Threshold test
passed Disk test

LOADING SYSTEM FILE

When the power-up self testing is complete, the operating system will be automatically loaded. If the operating system disk is not in the disk drive, the message "SYSTEM DISK NOT FOUND" will be displayed at the bottom of the screen and "NO DISK" will be displayed in front of disk test in place of "passed."

If the "NO DISK" message appears, turn off the instrument, insert the operating system disk into the disk drive, and apply power again.

Selectable Self Tests

The following self tests may be accessed individually in the Self Test menu:

- Analyzer Data Acquisition
- Scope Data Acquisition
- RS-232C
- BNC
- Keyboard
- RAM
- ROM
- Disk Drive
- Cycle through tests

To select a test, place the cursor on the test name and press SELECT. A pop-up menu appears with a description of the test. The self test does not begin until the cursor is placed on Single or Repetitive Test and the SELECT key is pressed.

When the test is complete, either "Passed", "Failed", or "Tested" will be displayed in the Self Test menu in front of the test. These tests are also used as troubleshooting aids. If a test fails, refer to Section 6 of the Service manual for information on the individual tests used for troubleshooting.

Specifications and Operating Characteristics

Introduction

This appendix lists the specifications, operating characteristics, and supplemental characteristics of the HP 1652B and HP 1653B Logic Analyzers.

Logic Analyzer Specifications

Probes Minimum Swing: 600 mV peak-to-peak.

Threshold Accuracy:	<u>Voltage Range</u>	<u>Accuracy</u>
	-2.0V to +2.0V	± 150 mV
	-9.9V to -2.1V	± 300 mV
	+2.1V to +9.9V	± 300 mV

Dynamic Range: ± 10 volts about the threshold.

State Mode **Clock Repetition Rate:** Single phase is 35 MHz maximum (25 MHz on the HP 1653B). With time or state counting, minimum time between states is 60 ns (16.67 MHz). Both mixed and demultiplexed clocking use master-slave clock timing; master clock must follow slave clock by at least 10 ns and precede the next slave clock by ≥ 50 ns.

Clock Pulse Width: ≥ 10 ns at threshold.

Setup Time: Data must be present prior to clock transition, ≥ 10 ns.

Hold Time: Data must be present after rising clock transition; 0 ns.

Data must be present after falling clock transition, 0 ns (HP 1653B);
data must be present after falling L clock transition, 0 ns (HP 1652B);
data must be present after falling J, K, M, and N clock transition, 1 ns
(HP 1652B).

Timing Mode Minimum Detectable Glitch: 5 ns wide at the threshold.

Logic Analyzer Operating Characteristics

The following operating characteristics are not specifications, but are typical operating characteristics for the HP 1652B/1653B logic analyzer which are included as additional information for the user.

Probes Input RC: 100 K Ω \pm 2% shunted by approximately 8 pF at the probe tip.

TTL Threshold Preset: +1.6 volts.

ECL Threshold Preset: -1.3 volts.

Threshold Range: -9.9 to +9.9 volts in 0.1 volt increments.

Threshold Setting: Threshold levels may be defined for pods 1 and 2 individually (HP 1653B). Threshold levels may be defined for pods 1, 2, and 3 on an individual basis and one threshold may be defined for pods 4 and 5 (HP 1652B).

Minimum Input Overdrive: 250 mV or 30% of the input amplitude, whichever is greater.

Maximum Voltage: \pm 40 volts peak.

Maximum Power Available Through Cables: 600 mA @ 5V per cable;
2 amp @ 5V per HP 1652B/1653B.

Measurement Configurations

Analyzer Configurations:	<u>Analyzer 1</u>	<u>Analyzer 2</u>
Timing		Off
Off		Timing
State		Off
Off		State
Timing		State
State		Timing
State		State
Off		Off

Channel Assignment: Each group of 16 channels (a pod) can be assigned to Analyzer 1, Analyzer 2, or remain unassigned. The HP 1652B contains 5 pods; the HP 1653B contains 2 pods.

State Analysis Memory

Data Acquisition: 1024 samples/channel.

Trace Specification

Clocks: Five clocks (HP 1652B) or two clocks (HP 1653B) are available and can be used by either one or two state analyzers at any time. Clock edges can be ORed together and operate in single phase, two phase demultiplexing, or two phase mixed mode. Clock edge is selectable as positive, negative, or both edges for each clock.

Clock Qualifier: The high or low level of four ORed clocks (HP 1652B) or one clock (HP1653B) can be ANDed with the clock specification. Setup time: 20 ns; hold time: 5 ns.

Pattern Recognizers: Each recognizer is the AND combination of bit (0, 1, or X) patterns in each label. Eight pattern recognizers are available when one state analyzer is on. Four are available to each analyzer when two state analyzers are on.

Range Recognizers: Recognizes data which is numerically between or on two specified patterns (ANDed combination of zeros and/or ones). One range term is available and is assigned to the first state analyzer turned on. The maximum size is 32 bits and on a maximum of 2 pods.

Qualifier: A user-specified term that can be anystate, nostate, a single pattern recognizer, range recognizer, or logical combination of pattern and range recognizers.

Sequence Levels: There are eight levels available to determine the sequence of events required for trigger. The trigger term can occur anywhere in the first seven sequence levels.

Branching: Each sequence level has a branching qualifier. When satisfied, the analyzer will restart the sequence or branch to another sequence level.

Occurrence Counter: Sequence qualifier may be specified to occur up to 65535 times before advancing to the next level.

Storage Qualification: Each sequence level has a storage qualifier that specifies the states that are to be stored.

Enable/Disable: Defines a window of post-trigger storage. States stored in this window can be qualified.

Prestore: Stores two qualified states that precede states that are stored.

Tagging

State Tagging: Counts the number of qualified states between each stored state. Measurement can be shown relative to the previous state or relative to trigger. Maximum count is 4.4×10^{12} .

Time Tagging: Measures the time between stored states, relative to either the previous state or to the trigger. Maximum time between states is 48 hours.

With tagging on, the acquisition memory is halved; minimum time between states is 60 ns.

Symbols

Pattern Symbols: User can define a mnemonic for the specific bit pattern of a label. When data display is SYMBOL, a mnemonic is displayed where the bit pattern occurs. Bit patterns can include zeros, ones, and don't cares.

Range Symbols: User can define a mnemonic covering a range of values. Bit pattern for lower and upper limits must be defined as a pattern of zeros and ones. When data display is SYMBOL, values within the specified range are displayed as mnemonic + offset from base of the range.

Number of Pattern and Range Symbols: 200 per HP 1652B/1653B.

Symbols can be down-loaded over RS-232C and HP-IB.

State Compare Mode

Performs post-processing bit-by-bit comparison of the acquired state data and compare data image.

Compare Image: Created by copying a state acquisition into the compare image buffer. Allows editing of any bit in the compare image to a zero, one, or don't care.

Compare Image Boundaries: Each channel (column) in the compare image can be enabled or disabled via bit masks in the compare image. Upper and lower ranges of states (rows) in the compare image can be specified. Any data bits that do not fall within the enabled channels and the specified range are not compared.

Stop Measurement: Repetitive acquisitions may be halted when the comparison between the current state acquisition and the current compare image is equal or not equal.

Displays: Compare Listing display shows the compare image and bit masks; Difference Listing display highlights differences between the current state acquisition and the current compare image.

State X-Y Chart Display

Plots the value of the specified label (on the y-axis) versus states or another label (on the x-axis). Both axes can be scaled by the user.

Markers: Correlated to state listing, state compare, and state waveform displays. Available as pattern, time, or statistics (with time counting on), and states (with state counting on).

Accumulate: Chart display is not erased between successive acquisitions.

State Waveform Display

Displays a state acquisition in a waveform format.

States/div: 1 to 104 states.

Delay: 0 to 1024 states.

Accumulate: Waveform display is not erased between successive acquisitions.

Overlay Mode: Multiple channels can be displayed on one waveform display line. Primary use is to view a summary of bus activity.

Maximum Number of Displayed Waveforms: 24.

Markers: Correlated to state listing, state compare, and X-Y chart displays. Available as pattern, time, or statistics (with time counting on), and states (with state counting on).

Timing Analysis Transitional Timing Mode

Sample is stored in acquisition memory only when the data changes. A time tag stored with each sample allows reconstruction of a waveform display. Time covered by a full memory acquisition varies with the number of pattern changes in the data.

Sample Period: 10 ns.

Maximum Time Covered By Data: 5000 seconds.

Minimum Time Covered by Data: 10.24 us.

Glitch Capture Mode

Data sample and glitch information is stored every sample period.

Sample Period: 20 ns to 50 ms in a 1-2-5 sequence dependent on sec/div and delay settings.

Memory Depth: 512 samples/channel.

Time Covered by Data: Sample period X 512

Waveform Display

Sec/div: 10 ns to 100 s; 0.01% resolution.

Screen Delay: -2500 s to 2500 s; presence of data is dependent on the number of transitions in data between trigger and trigger plus delay (transitional timing).

Accumulate: Waveform display is not erased between successive acquisitions.

Hardware Delay: 20 ns to 10 ms.

Overlay Mode: Multiple channels can be displayed on one waveform display line. Primary use is to view a summary of bus activity.

Maximum Number Of Displayed Waveforms: 24

Time Interval Accuracy

Channel to Channel Skew: 4 ns typical.

Sample Period Accuracy: 0.01% of sample period.

Time Interval Accuracy: \pm (sample period + channel-to-channel skew + 0.01% of time interval reading).

Trigger Specification

Asynchronous Pattern: Trigger on an asynchronous pattern less than or greater than a specified duration. Pattern is the logical AND of a specified low, high, or don't care for each assigned channel. If pattern is valid but duration is invalid, there is a 20 ns reset time before looking for patterns again.

Greater Than Duration: Minimum duration is 30 ns to 10 ms with 10 ns or 0.01% resolution, whichever is greater. Accuracy is +0 ns to -20 ns. Trigger occurs at pattern + duration.

Less Than Duration: Maximum duration is 40 ns to 10 ms with 10 ns or 0.01% resolution, whichever is greater. Pattern must be valid for at least 20 ns. Accuracy is +20 ns to -0 ns. Trigger occurs at the end of the pattern.

Glitch/Edge Triggering: Trigger on a glitch or edge following a valid duration of an asynchronous pattern while the pattern is still present. Edge can be specified as rising, falling, or either. Less than duration forces glitch and edge triggering off.

Measurement and Display Functions

Autoscale (Timing Analyzer Only)

Autoscale searches for and displays channels with activity on the pods assigned to the timing analyzer.

Acquisition Specifications

Arming: Each analyzer can be armed by the run key, the other analyzer, or the external trigger in port.

Trace Mode: Single mode acquires data once per trace specification; repetitive mode repeats single mode acquisitions until stop is pressed or until the time interval between two specified patterns is less than or greater than a specified value, or within or not within a specified range. There is only one trace mode when two analyzers are on.

Labels

Channels may be grouped together and given a six character name. Up to 20 labels in each analyzer may be assigned with up to 32 channels per label. Primary use is for naming groups of channels such as address, data, and control busses.

Indicators

Activity Indicators: Provided in the Configuration, State Format, and Timing Format menus for identifying high, low, or changing states on the inputs.

Markers: Two markers (X and 0) are shown as dashed lines on the display.

Trigger: Displayed as a vertical dashed line in the timing waveform display and as line 0 in the state listing display.

Marker Functions

Time Interval: The X and 0 markers measure the time interval between one point on a timing waveform and trigger, two points on the same timing waveform, two points on different waveforms, or two states (time tagging on).

Delta States (State Analyzer Only): The X and 0 markers measure the number of tagged states between one state and trigger, or between two states.

Patterns: The X and 0 markers can be used to locate the nth occurrence of a specified pattern before or after trigger, or after the beginning of data. The 0 marker can also find the nth occurrence of a pattern before or after the X marker.

Statistics: X to 0 marker statistics are calculated for repetitive acquisitions. Patterns must be specified for both markers and statistics are kept only when both patterns can be found in an acquisition. Statistics are minimum X to 0 time, maximum X to 0 time, average X to 0 time, and ratio of valid runs to total runs.

Run/Stop Functions

Run: Starts acquisition of data in a specified trace mode.

Stop: In single trace mode or the first run of a repetitive acquisition, STOP halts the acquisition and displays the current acquisition data. For subsequent runs in repetitive mode, STOP halts the acquisition of data and does not change current display.

Data Display/Entry

Display Modes: State listing; timing waveforms; interleaved, time-correlated listing of two state analyzers (time tagging on); time-correlated state listing and timing waveform display (state listing in upper half, timing waveform in lower half, and time tagging on).

Timing Waveform: Pattern readout of timing waveforms at X or 0 marker.

Bases: Binary, Octal, Decimal, Hexadecimal, ASCII (display only), and User-defined symbols.

Oscilloscope Specifications

The following specifications are the performance standards or limits against which the oscilloscope in the HP 1652B/1653B is tested.

Vertical Bandwidth (-3 dB): dc to 100 MHz (single shot).

DC Gain Accuracy: $\pm 3\%$ of full scale.

DC Offset Accuracy: $\pm (2 \text{ mV} + 2\% \text{ of the channel offset} + 2.5\% \text{ of full scale})$.

Voltage Measurement Accuracy (DC): (Gain accuracy + ADC resolution + Offset accuracy).

Horizontal Time Interval Measurement Accuracy: $\pm (2\% \times \text{s/div} + 0.01\% \times \text{delta-t} + 500 \text{ ps})$.

Trigger Sensitivity: 10% of full screen.

Oscilloscope Operating Characteristics

The following operating characteristics are not specifications, but are typical operating characteristics for the oscilloscope in the HP 1652B/1653B. These are included as additional information for the user.

Vertical (at BNC) Transition Time (10% to 90%): $\leq 3.5 \text{ ns}$.

Number of Channels: 2.

Vertical Sensitivity Range: 15 mV/div to 10 V/div (1:1 probe).

Vertical Sensitivity Resolution: Adjustable 2 digit resolution.

Maximum Sample Rate: 400 MSamples/second.

Analog-to-Digital Conversion: 6 bit real-time.

Analog-to-Digital Resolution: $\pm 1.6\%$ of full scale.

Waveform Record Length: 2048 points.

Input R: $1\text{ M}\Omega \pm 1\%$ or $50\ \Omega \pm 1\%$.

Input C: Approximately 7 pF.

Input Coupling: dc.

Maximum Safe Input Voltage:

1 M Ω input,	$\pm 250\text{ V}$ [dc + peak ac (< 10 kHz)]
50 Ω input,	$\pm 5\text{ V RMS}$

DC Offset Range (1:1 Probe):

<u>Vertical Sensitivity</u>	<u>Available Offset</u>
$\leq 50\text{ mV/div}$	$\pm 2.0\text{ V}$
100 mV/div - 200 mV/div	$\pm 10\text{ V}$
500 mV/div - 1 V/div	$\pm 50\text{ V}$
$\geq 2\text{ V/div}$	$\pm 125\text{ V}$

$\pm 5\text{ V}$ max if input impedance is at 50 Ω .

DC Offset Resolution (1:1 Probe)

<u>Vertical Sensitivity</u>	<u>Resolution</u>
$\leq 50\text{ mV/div}$	200 μV
100 mV/div - 200 mV/div	1 mV
500 mV/div - 1 V/div	5 mV
$\geq 2\text{ V/div}$	25 mV or 4 digits of resolution, whichever is greater.

Probe Factors: Any integer ratio from 1:1 to 1000:1.

Channel Isolation:

40 dB: dc to 50 MHz.

30 dB: 50 MHz to 100 MHz (with channels at equal sensitivity).

Horizontal Timebase Range: 5 ns/div to 5 s/div.

Timebase Resolution:

<u>Time/Division Setting</u>	<u>Resolution</u>
$t < 10 \text{ ns/div}$	100 ps
$t \geq 10 \text{ ns/div}$	adjustable with 3-digit resolution

Delay Pre-trigger Range: 5 X (s/div) @ $5 \text{ ns} \leq \text{s/div} \leq 500 \text{ ns}$
 $2.5 \mu\text{s X (s/div) @ } 500 \text{ ns} \leq \text{s/div} \leq 5 \text{ s}$

Delay Post-trigger Range:

<u>Time/Division Setting</u>	<u>Available Delay</u>
50 ms - 5 s/div	40 X (s/div)
$100 \mu\text{s} - 20 \text{ ms/div}$	1 s
5 ns - $50 \mu\text{s/div}$	10,000 X (s/div)

Trigger Triggering on either input channel, rising or falling edge.

Trigger Level Range: dc Offset ± 5 divisions.

Trigger Level Resolution (1:1 Probe):

<u>Trigger Level</u>	<u>Resolution</u>
$\leq 50 \text{ mV/div}$	$400 \mu\text{V}$
$100 \text{ mV/div} - 200 \text{ mV/div}$	2 mV
$500 \text{ mV/div} - 1 \text{ V/div}$	10 mV
$\geq 2 \text{ V/div}$	50 mV

Arming: Armed by the Run key, external BNC low input, or by Analyzer 1 or 2.

Trigger Modes

Immediate: Triggers immediately after the arming condition is met.

Edge: Triggers on the rising or falling edge from channel 1 or 2.

Auto-Trigger: Self-triggers if no trigger condition is found within approximately 1 second after arming.

Trigger Out: Arms Analyzer 1 or 2, or triggers the rear panel BNC.

Waveform Display **Display Formats:** 1 to 8 oscilloscope waveforms can be displayed.

Display Resolution: 500 points horizontally, 240 points vertical.

Display Modes

Normal: New acquisitions replace old acquisitions on screen.

Accumulate: New acquisitions are added to the screen and displayed with previous acquisitions until a parameter is changed and a new acquisition is made.

Average: New acquisitions are averaged with older acquisitions and displayed. Maximum number of averages is 256.

Overlay: Channel 1 and 2 can be overlaid in the same display area.

Connect-the-dots: Provides a display of the sample points connected by straight lines.

Waveform Reconstruction: A reconstruction filter fills in missing data points when timebase is ≤ 100 ns/Div or when timebase is reduced to a setting where fewer than 500 samples are on screen.

Waveform Math: Display capability of A-B and A + B functions is provided.

Mixed Mode: Oscilloscope plus logic analyzer displays on the same screen.

Measurement Aids

Time Markers: Two vertical markers labeled X and O. Voltage levels are displayed for each marker. Time interval measurements can be made between any two events.

Automatic Search: Searches for a specified absolute or percentage voltage level at a positive or negative edge, count adjustable from 1 to 1024.

Auto Search Statistics: Mean, maximum, and minimum values for elapsed time from X to O markers for multiple runs. Number of valid runs and total number of runs displayed.

Trigger Level Marker: Horizontal trigger level marker displayed in Trace/Trigger menu only.

Automatic Measurements: The following pulse parameter measurements can be performed automatically:

- Frequency
- Period
- V p-p
- Rise time
- Fall time
- Preshoot
- Overshoot
- + pulse width
- pulse width

Grid: May be turned on or off.

Setup Aids

Autoscale: Auto sets the vertical and horizontal ranges, offset, and trigger levels to display the input signals. Requires an amplitude above 10 mV peak, and a frequency between 50 Hz and 100 MHz.

Preset: Scales the vertical range, offset, and trigger level to predetermined values for displaying ECL or TTL waveforms.

Calibration: Attenuation, offset, gain, trigger, and delay set to defaults.

Probe Compensation Source: External BNC supplies square wave approximately -400 mV to -900 mV at approximately 1.25 kHz.

Interactive Measurements

Acquisition Oscilloscope, timing, and state can occur simultaneously or in series.

Mixed Displays Timing channels and oscilloscope channels can be displayed on the same screen. Multiple state machine listings can be displayed with time tags on the same screen. Timing channels can be displayed with a state listing with Time Tags turned on. State listings with time tags, timing channels, and oscilloscope channels can be displayed on the same screen.

Time Correlation All modules are time correlated with the exception of when the oscilloscope is being armed by the logic analyzer, and when the oscilloscope is not in trigger immediate mode.

**Time Interval
Accuracy
Between Modules** Equals the sum of channel to channel time interval accuracies of each machine used for a measurement.

General Characteristics

The following general characteristics for the HP 1652B/1653B include the environment operating conditions, shipping weights, and instrument dimensions.

Operating Environment

Instrument:

Operating: 0°C to +55°C (32°F to +131°F)

Non-operating: -40°C to +70°C (-40°F to +158°F)

Probes and Cables: 0°C to 65°C (+32°F to +149°F)

Disk Media: 10°C to 50°C (+50°F to +149°F).

Humidity:

Instrument:

Operating: Up to 95% relative humidity (non-condensing) at +40°C (+104°F)

Non-operating: Up to 90% relative humidity at +65°C (+149°F)

Disk Media: 8% to 80% relative humidity at +40°C (+104°F)

Altitude

Operating: Up to 4600 meters (15,000 ft)

Non-operating: Up to 15,300 meters (50,000 ft)

Vibration

Operating: Random vibration 5-500 Hz, 10 minutes per axis, 0.3 g (rms)

Non-operating: Random vibration 5-500 Hz, 10 minutes per axis, 2.41 g (rms);

Resonant search 5-500 Hz swept sine, 1 Octave/minute sweep rate, 0.75 g (0-peak), 5 minute resonant dwell at 4 resonances per axis.

Power Requirements 115/230 Vac, -25% to +15%, 48-66 Hz, 200 W max.

Weight 10.0 kg (22 lbs) net; 18.2 kg (40 lbs) shipping.

Dimensions Refer to the outline drawing below.

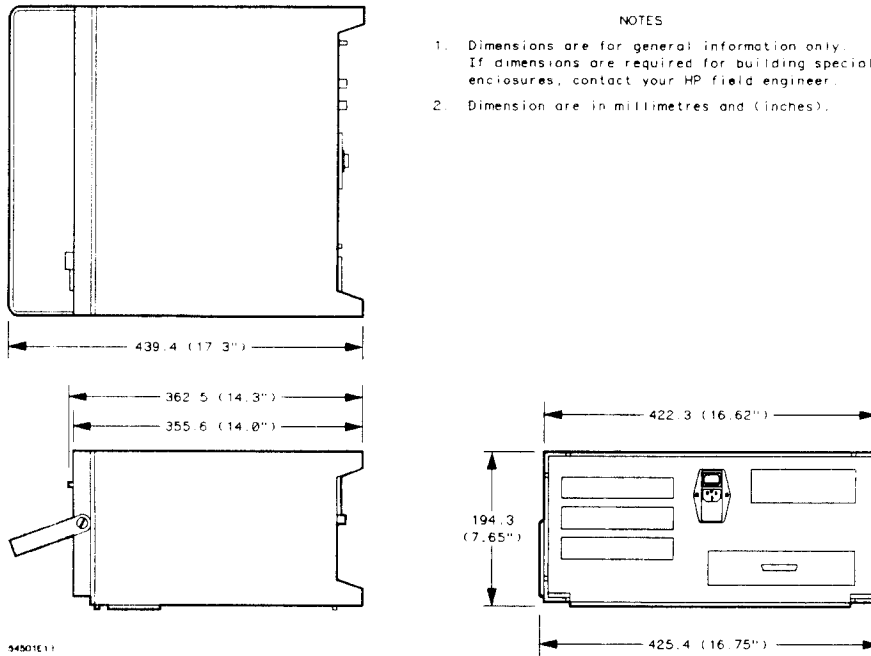

Figure F-1. HP 1652B/1653B Dimensions

restart	10-14
branching	
multiple levels	10-17
secondary	10-15
branching qualifier	10-8

C

cables for printer	7-3
Calibration	24-1, D-1
Cancel field	5-4
Changing Alpha Entries	3-15
Channel Menu	23-1
Channel Menu Fields	
Impedance	23-5
Input	23-1
Offset	23-3
Preset	23-5
Probe	23-4
V/Div	23-2
CHS Key	3-4
Clear Entry Key	3-3
clock	
demultiplex	9-10
master	9-10
mixed	9-11
normal	9-9
period (state)	9-12
slave	9-10
state	9-7
Closing Pop-up Menus	3-9
Compare Image	12-3
Bit Editing of the	12-4
Creating a	12-3
Masking Channels in the	12-5
Saving	12-8
Compare Listing Display	12-2
Compare Range	12-6
Specifying a	12-6
Compensation Signal	2-7

Index-2

Configuration Capabilities	
HP 1652B capabilities	1-2
HP 1653B capabilities	1-3
Connect dots Field	25-31
Connecting	
analyzer to target system	2-8
Grabbers to probes	2-12
Grabbers to test points	2-12
Labels to pods, probes, cables	2-13
Other HP Printers	7-9
Pods to probe cables	2-10
probe cables to analyzer	2-9
Continue field	5-4
Copy	5-7, 6-1
Copying a File	6-15
count	10-18
States	10-20
Time	10-18
Cursor	3-7

D

data	
bits	5-15
time-correlating	21-11, 27-12
Delay	23-17
from Trigger (State)	14-5
Delay (timing)	19-9
Deleting Waveforms (State)	14-4
Demultiplex (clock)	9-10
Difference Listing	
Locating Mismatches in	12-8
Difference Listing Display	12-2
disk	
drive operations	6-1
format (LIF)	6-7
Installing a Blank Disk	6-6
operations	5-3
Disk Drive	3-5
Disk Eject Button	3-5

G		Setting RS-232C for HP Printers for Non-HP Printers	7-5 7-5
General Purpose Probe Interface	2-2	inverse assembled data	
glitch triggering	18-13	How to Display	A-19
Glitch Acquisition mode	18-5	inverse assembler files	
Grabbers	2-6	loading	A-18
H		K	
Hooking Up Your Printer	7-2	Knob	3-4
HP-IB		L	
printer cables	7-3	Label Value vs. Label Value (State Chart)	13-4
I		Label Value vs. States (State Chart)	13-3
I/O menu	5-1	labels	17-3
Accessing the	5-1	State Format menu	9-3
I/O Menu Key	3-3	State Trace	10-22
I/O Port Configuration menu	5-12	symbols	17-8
Immediate Trigger Mode		Timing Format menu	17-3
Armed by	24-3	Timing Trace menu	18-6
Impedance Field	23-5	Level Field	24-5
Indicator Light	3-5	Line Switch	D-10
indicators		Line Voltage Selection	D-7
activity	20-5	Load	5-5, 6-1
Input Field	23-1	loading a file	6-11
Input Voltage for Probes	2-8	Logic Analyzer	
Inputs 1 and 2	3-5	description	1-1
Installation	D-1	key features	1-4
Installing a Blank Disk	6-6	turning it on	1-7
Intensity Control	D-10	M	
interface		Maintenance	D-1
Configuring	5-13	Making Hardcopy Prints	7-1
HP-IB	5-13, 7-1		
RS-232C	5-14, 7-1		
Setting HP-IB for HP Printers	7-4		

Marker Measurements	25-12	State Chart	8-9 - 8-10
markers		State Compare	8-6
Pattern (state)	11-4	State Format	8-2
Pattern (timing)	19-5	State Listing	8-5
Statistics (state)	11-6	State Trace	8-3
Statistics (timing)	19-6	State Waveform	8-7 - 8-8
Time (state)	11-6	timing analyzer	16-1
Time (timing)	19-4	Timing Format	16-2
Timing Waveforms menu	19-3	Timing Trace	16-3
X and O	20-10	Timing Waveform	16-4
Markers Field for Scope		Trigger Menu	22-3
Sample Period Display	25-14	Waveform Selection	22-5
Search	25-16	Waveforms Menu	22-4
Specify Search Markers	25-16	menus	
Statistics	25-23	Disk Operations	5-3, 6-1
Time	25-14	I/O	5-1
X-O Pattern from start	25-22	I/O Port Configuration	5-12
master clock	9-10	Specify Symbols (state)	9-7, 9-12
measurement example		Specify Symbols (timing)	17-7
state analyzer	15-1	State Chart	13-1
timing analyzer	20-1	State Compare	12-1
timing/state analyzer	21-1	State Format Specification	9-1
measurements		State Listing	11-1
microprocessor	A-1	State Trace	10-1
memory		State Waveform	14-1
acquisition	18-4 - 18-5	State Waveforms	14-1
menu fields		Timing Format Specification	17-1
Specify Symbols (state)	9-13	Timing Trace Specification	18-1
Specify Symbols (timing)	17-8	Timing Waveforms	19-1
st/Div (states-per-division)	14-4	Microprocessor Specific	
State Format Specification	9-3	Measurements	A-1
State Listing menu	11-3	Microprocessors Supported	A-3
State Trace menu	10-2	mixed clocks	9-11
Timing Format Specification	17-3	Mixed Mode Displays	26-1
Timing Trace Specification	18-2	Arming the Scope	26-4
Timing Waveforms menu	19-3	Displaying Timing Waveforms	26-5
Menu Keys	3-2	State/State	26-3
menu maps		State/Timing/Scope Mixed	
Channel Menu	22-2	Mode Display	26-8
Specify Markers	22-5	Time-Correlated Displays	26-9
state analyzer	8-1	Timing/Scope	26-4

Timing/State	26-2
Mixed Mode Field	26-1
Mode Field	24-2
Edge	24-4
Immediate	24-3

N

name	
label	9-4, 17-4
symbol	17-10
Name Field	4-3

O

O to Trig(ger)	19-4
occurrence counter	10-9
Offset Field	23-3
Operating Characteristics	F-1
Operating System Disk	6-18
Duplicating the	6-18
Operating System-loading	D-9
Overlapping Timing Waveforms	21-14

P

Pack Disk	5-9, 6-1
Packing a Disk	6-17
paper width	5-17
Setting the	7-6
parity	5-15
pattern	
recognizers	10-2
Pattern Fields (state)	10-24
patterns	10-23
Duration (present for ____)	18-9
fields	10-22

find	18-7
Pod Clock	9-9
Pod Fields	4-6
Pod Grounding	2-5
pod threshold	
ECL	17-6
TTL	17-6
user-defined	17-6
Pod Thresholds	2-8
pods	
clock	9-9
threshold	9-6, 17-6
Polarity (Pol)	9-4, 17-4
Pop-up Menus	3-9
Power Cord Configurations	D-4
preprocessors	A-2
Preset Field	23-5
prestore	10-21
print	
All	5-2, 7-7
Screen	5-2, 7-7
Starting the Printout	7-7
Print All	5-2, 7-7
Print Screen	5-2, 7-7
printer	5-16
printers	
alternate	7-2
Hooking Up	7-2
Other HP Printers	7-9
supported	7-1
Probe Cables	2-6
Probe Connecting	
Analyzer to Target System	2-8
Disconnecting Probes from Pods	2-11
Grabbers to Probes	2-12
Grabbers to Test Points	2-12
Labels to Pods, Probes, Cables	2-13
Pods to Probe Cables	2-10
Probe Cables to Analyzer	2-9
Probe Field	23-4
Probe Grounding	2-6

Probe Inputs for Scope	2-7
Probe Pod Assemblies	2-4
Probes	2-5
Probing Options	
General Purpose Probing	2-3
HP 10269C General Purpose	
Probe Interface	2-2
HP 10320C User-Definable	
Interface	2-1
Termination Adapter	2-3
Probing System for Analyzer	
description	2-4
Grabbers	2-6
Maximum Probe Input Voltage	2-8
Pod Grounding	2-5
Probe Cable	2-6
Probe Grounding	2-6
Probe Pod Assemblies	2-4
Probes	2-5
Signal Line Loading	2-8
Probing System for Scope	
Compensation Signal Outputs	2-7
description	2-7
External Trigger Inputs	2-7
Maximum Probe Input Voltage	2-8
Probe Inputs	2-7
protocol	5-14
Purge	5-10, 6-1
Purging a File	6-14

Q

Qualifer Field (state)	10-23
qualifier	10-2
branching	10-8
fields	10-22
storage	10-8

R

range	
recognizers	10-2
ranges	10-24
Rear-Panel Controls and Connectors	
External Trigger BNCs	3-6
Fan	3-7
HP-IB Interface Connector	3-7
Intensity Control	3-6
Line Power Module	3-6
Pod Cable Connectors	3-6
Probe Compensation Signal	3-7
RS-232C Interface Connector	3-6
Recommended Protocol (RS-232C)	7-6
Rename	5-9, 6-1
repetitive	
trace mode (state)	10-13
trace mode (timing)	18-3
Repetitive Run Mode	24-7
Replacing Waveforms (State)	14-3
Returning to system configuration	3-8
Roll Data	3-16
Roll Keys	3-4
RS-232C	
default configuration	7-6
printer cables	7-3
recommended protocol	7-6
setting for HP printers	7-5
setting for non-HP printers	7-5
Run Key	3-3
Run Mode Field	24-7
Repetitive Mode Run	24-7
Single Mode Run	24-7

S

		An Overview	8-1
		menu maps	8-1
		State Chart menu	13-1
		Accessing the	13-1
sample period	19-3	state clock	9-7
Scope		State Compare menu	
Introduction	22-1	Accessing the	12-2
Scope Field	25-1	State Format Specification menu	9-1
Scope Menus Overview	22-6	Accessing the	9-1
Scope On/Off Field	4-5	fields	9-3
Select Key	3-4	State Listing menu	11-1
Selecting a Waveform (State)	14-2	Accessing the	11-2
Selecting an Address (HPIB)	5-13	fields	11-3
Selecting Fields	3-9	state tagging	10-20
Selecting Menus	3-7	State Trace menu	10-1
Selecting Options	3-10	Accessing the	10-2
self test	5-18	fields	10-2
Self Tests-powerup	E-1	State Waveforms menu	14-1
sequence levels	10-6	Accessing the	14-1
Delete Level	10-7	State/State Mixed Mode Display	26-3
Insert Level	10-7	Statistics	25-23
Reading the Display	10-11	Stop bits	5-15
Signal Line Loading	2-8	Stop Key	3-3
single		Stop Measurement	
trace mode (state)	10-13	state	11-5
trace mode (timing)	18-3	Stop Measurement (timing)	19-5
Single Run Mode	24-7	storage macro	10-9
slave clock	9-10	storage qualifier	10-8
Slope Field	24-6	Store	5-5, 6-1
Source Field	24-4	Store exception to disk	
Specifications	F-1	state	11-5
Specify Search Markers		State Compare	12-7
Greater than	25-20	timing	19-6
In/Not IN Range	25-21	Storing to a Disk	6-9
Less than	25-19	supported printers	7-1
Type	25-17	Switching Between Analyzer	
X-O Marker set on	25-17	and Scope	3-8
Specifying Edges	3-19	symbols	17-7
Specifying Patterns	3-18	base	9-14, 17-8
st/Div (states-per-division)	14-1, 14-4	label	9-13, 17-8
state analyzer	8-1	name	9-15, 17-10

Toggle Fields	3-11
User-Definable Interface	2-1

V

V/Div Field	23-2
view size	
symbol	17-10

W

Waveform Selection	23-6
Insert/Delete	23-9
Math	23-12
Modify	23-10
Overlay	23-11
Turning them ON/OFF	23-8
Waveforms Menu	
Auto-Measure Field	25-1
Connect dots Field	25-31
Description	25-1
Display Field	25-29
Marker Measurements	25-12
Markers Field	25-13
Scope Field	25-1
Search Marker Measurement	
Example	25-24

X

X and O markers	
State Chart	13-5
State Waveform	14-5
Timing Waveforms	20-10
X to Trig(ger)	19-4